

MAYOR
Shirley Sessions

CITY COUNCIL
Barry Brown, Mayor Pro Tem
John Branigin
Jay Burke
Nancy DeVetter
Spec Hosti
Monty Parks



CITY MANAGER
Dr. Shawn Gillen

CLERK OF COUNCIL
Jan LeViner

CITY ATTORNEY
Edward M. Hughes

CITY OF TYBEE ISLAND

AMENDED AGENDA

REGULAR MEETING OF TYBEE ISLAND CITY COUNCIL

November 12, 2020 at 6:30 PM

Please silence all cell phones during Council Meetings

Consideration of Items for Consent Agenda 6:30PM

Opening Ceremonies

- Call to Order
- Invocation
- Pledge of Allegiance

Announcements

Consideration of the approval of the minutes of the meetings of the Tybee island City Council

1. Minutes, City Council Meeting October 22, 2020
2. Notes, City Council Workshop October 29, 2020

Reports of Staff, Boards, Standing Committees and/or Invited Guest. Limit reports to 10 minutes.

3. Kim Webster: Tourism Council Activities Year-to-Date

Citizens to be Heard: Please limit comments to 3 minutes. Maximum allowable times of 5 minutes.

Consideration of Approval of Consent Agenda

Public Hearings

4. Text Amendment: Sec. 3-190 Swimming pool requirements.

Consideration of Bids, Contracts, Agreements and Expenditures

5. Approval of itemized list of budget amendments to the 2021 City budget to include specific explanations for the budget amendments. In total, the general fund budget expenditures will increase \$562,055.
6. Professional Services Agreement with Goodwyn Mill and Cawood, Inc.

P.O. Box 2749 – 403 Butler Avenue, Tybee Island, Georgia 31328-2749
(866) 786-4573 – FAX (866) 786-5737
www.cityoftybee.org



7. Approval of award of contract subject to contract approval for south-end bathrooms with Johnson Laux Construction. The purpose of this project is to construction restrooms, changing rooms, and showers on the south end per the Strand Promenade Master Plan.
8. Approval of contract with the Coastal Regional Commission to provide technical assistance and planning services.
9. The current Human Resources Director will retiring at the end of the year. After a review of the service delivery options we are recommending we make a change to our structure. Through expanded use of services of our health insurance brokerage firm BKS Partners, shifting of work tasks from HR to Finance, and shifting training to Cornerstone training we can reduce the role of our staff from a department director to a technician level. The position will report directly to the City Manager and be part of the City Manager budget. This will result in an overall budgetary reduction. The exact amount of the reduction will depend on the salary of the new staff person.
10. **Non-Award of ITB 2020-755, Memorial Pavilion due to budget constraints.**

Consideration of Ordinances, Resolutions

11. Second Reading, 2020-20, Noise Ordinance
12. Second Reading, 2020-21, Alcohol Restrictions (Address discussion at workshop for a committee to be formed)
13. Second Reading, 2020-22, Tree Permit Required, Sec 7-040
14. Resolution, 2020-15, Authorizing Adoption of the Chatham County Multi-Jurisdictional Pre-Disaster Hazard Mitigation Plan

Council, Officials and City Attorney Considerations and Comments

15. Bubba Hughes: Discussion Only: 2020-24, Amendment, By the Drink Licensing to require Liability Insurance, Sec 6-48
16. Shawn Gillen: Zones/Ordinance on the Beach
17. Shawn Gillen: Discussion of STVR online Registration Fee Payments

Other Commission Minutes

18. Planning Commission Minutes -October 19, 2020

Executive Session

Discuss litigation, personnel and real estate

Possible vote on litigation, personnel and real estate discussed in executive session

Adjournment

Individuals with disabilities who require certain accommodations in order to allow them to observe and/or Participate in this meeting, or who have questions regarding the accessibility of the meeting or the facilities are required to contact Jan LeViner at 912.472.5080 promptly to allow the City to make reasonable accommodations for those persons.

***PLEASE NOTE:** Citizens wishing to speak on items listed on the agenda, other than public hearings, should do so during the citizens to be heard section. Citizens wishing to place items on the council meeting agenda must submit an agenda request form to the City Clerk's office by Thursday at 5:00PM

prior to the next scheduled meeting. Agenda request forms are available outside the Clerk's office at City Hall and at www.cityoftybee.org.



THE VISION OF THE CITY OF TYBEE ISLAND

"is to make Tybee Island the premier beach community in which to live, work, and play."



THE MISSION OF THE CITY OF TYBEE ISLAND

"is to provide a safe, secure and sustainable environment by delivering superior services through responsible planning, preservation of our natural and historic resources, and partnership with our community to ensure economic opportunity, a vibrant quality of life, and a thriving future."

File Attachments for Item:

1. Minutes, City Council Meeting October 22, 2020

Consideration of Items for Consent Agenda

Mayor Sessions called the Consent Agenda to order at 6:30PM. Those present were Jay Burke, Monty Parks, John Branigin, and Barry Brown,. Also attending were Dr. Shawn Gillen, City Manager; Bubba Hughes, City Attorney; Tracy O'Connell, Assistant City Attorney; George Shaw, Director, Community Development; and Janet LeViner, Clerk of Council. Nancy DeVetter and Spec Hosti attended via telephonic conference.

Mayor Sessions listed the following items on the consent agenda:

- Minutes: City Council Meeting, October 8, 2020
- T-Mobile - 5th Amendment to Water Tower Attachment Lease Agreement

Mayor Sessions called the regular meeting to order. All those present for the consent agenda were present.

Opening Ceremonies

- Call to Order
- Invocation: Rev. Sue Jackson, Trinity Methodist Church
- Presentation of Colors and Pledge of Allegiance

Recognitions and Proclamations

Tybee Island Fire Department, First Responders and Lifeguards. Chief Harrell introduced the Tybee Island Fire Department members to include First Responders, Life Guards and Volunteers. Mayor Sessions thanked each for their dedication. Certificates of Appreciation were given to each member.

Janice Elliott, HR Director recognized **Employee of Quarter(s)** with a Certificate and gift card:

- **First Quarter: Cale Mathis, Department of Public Works**
- **Second Quarter: Melissa Freeman, Finance Department**
- **Third Quarter: Jennifer Wittendorf, Tybee Island Fire Department**
- **Fourth Quarter: Danny Rapposeli, Water/Sewer Department**

Reports of Staff, Boards, Standing Committees and/or Invited Guest. Limit reports to 10 minutes.

Demery Bishop approached Mayor and Council to give an update on the **STVR Work Group**. Mr. Bishop addressed the proposed Ordinance included in the packet before them tonight (attached). Mayor Sessions thanked Mr. Bishop and his committee for all their hard work.

Kim Webster: Tourism Council Activities Year-To-Date. Ms. Webster rescheduled for November 12, 2020.

Frank McColm and Jerry Davis approached Mayor and Council to give an **Update on the HMGP Grant**. Mr. Davis stated there were twelve homes originally that were approved for the Grant and of those twelve only ten are moving forward. Seven residents have completed their papers, six have received bids from contractors and building permits have been approved. An extension has been requested due to COVID until June 2022. This extension is currently at FEMA for approval. Mr. Davis reported there is no update on the additional homes in the second phase. Mayor Sessions thanked Mr. McColm and Mr. Davis.

Citizens to be Heard.

- **Benny Ward** requested Mayor and Council not approve the proposed Alcohol Restrictions
- **Vicki Worden** requested Mayor and Council not approve the proposed Alcohol Restrictions
- **Laurie Gulbranson** requested Mayor and Council not approve the proposed Alcohol Restrictions. Tybee is a special place and is the main reason they moved here. She is not in favor of the proposed Alcohol Restrictions as she will not be able to take her beverages to the beach and enjoy the sunrise or sunsets.
- **Tim Arnold** requested Mayor and Council to approve the proposed Alcohol Restrictions
- **Paul Lewis** requested Mayor and Council address the tourist problem rather than address the locals. Mr. Lewis also stated the Alcohol Restrictions are ridiculous.
- **Shawna Lewis** stated she loves the tourists that visit the Island and is in favor of open containers. She also feels Mayor and Council need to enforce the ordinances that are in place as the residents have rights and are not to be dictated to. She is not in favor of the ban of Alcohol Restrictions.
- **Eric Thomas** spoke on the proposed Noise Ordinance and asked Mayor and Council not to approve the proposed Ordinance
- **Stuart Smith** stated he is not in favor of the ban of open containers. He asked Mayor and Council not to approve the proposed ordinance on Alcohol Restrictions.
- **Jen Knox** stated she is not in favor of the proposed Alcohol Restrictions Ordinance and asked for clarification of "open container". Ms. Knox recommended the business owners meet with the TIPD to enforce the current ordinances rather than creating more.
- **Jenny Orr** stated one of her concerns are the coolers beach goers bring to the beach goers bring and feels that is the main abuse of alcohol. Ms. Orr asked Mayor and Council to look at that as it is not part of the business community. She also recommended a single serve for customers as this is done in other beach communities.
- **Jerry Cornwell** respectively proposed a meeting with representatives from the TIPD and businesses to address each other's concerns and work toward a solution.
- **Michael Hall** shared his concerns with the proposed Noise Ordinance. He asked for clarification on how the proposed Noise Ordinance in regards to the distance being measured. Mr. Hall also stated this is a potential to not have answers.
- **Ron Goral** stated he is not in favor of the proposed Alcohol Restrictions and is questioning where the restrictions would apply. He does have a petition to present to Mayor and Council but will hold until later.
- **Marianne Bramble** stated both proposed ordinances before Mayor and Council are unenforceable as written. She recommended both be tabled until such time as discussions with the business owners have taken place.
- **Michael Flores** stated setting more ordinances are not enforceable. He asked for Mayor and Council and the TIPD make more visits to establishments to build good faith. Mr. Flores is in favor of a meeting with Mayor and Council and the business owners.
- **Joe Sheffield** feels the single most problem on the Island is public behavior. He recommended enforcement of current ordinances. He is not in favor of the Alcohol Restrictions.
- **Des Ruman** stated he does support the proposed Noise Ordinance.
- **Michael Crosby** asked Mayor and Council not to pass the proposed Alcohol Restrictions. He is a server and by passing the proposed ordinance it will take revenue from the local business owners as well as the wait staff.

Monty Parks made a motion to approve the consent agenda. **John Branigin** seconded. Vote was unanimous to approve, 6-0.

Consideration of Bids, Contracts, Agreements and Expenditures

Results of the Classification and Compensation Study conducted by Evergreen Solutions and to request that the City Council review and implement the plan. Angele Yazbec, Evergreen Solutions

approached Mayor and Council to present the results of the recent Classification and Compensation Study that was done. Information is included in their packets before them tonight. She stated they developed a separate pay plan for Public Safety staff as the salary ranges seems to change more compared to other types of classifications. This is considered an open end design. Ms. Yazbec stated after meetings with the City Manager, Finance, and Human Resources Directors it was agreed to move to the Mid-point Tier 3 Year Class and Comp is the most appropriate method for adjusting employees' salaries. She recommended the City, moving forward, continues to advance employees' salaries with cost of living adjustments and implement and maintain and continue to administer a performance evaluation system. Mayor Sessions asked Dr. Gillen to respond to his plan moving forward. Dr. Gillen stated as far as the implementation of the Plan and how the range will impact the TIPD. He outlined the budgetary impact and how it could be phased in to the budget. They are recommending, beginning in January 2021, they move the entire Public Safety (all sworn staff) to the minimum range which is approximately \$108,000 and starting in July 2021, another \$108,000. January 2022 include the remaining staff with increase in salaries. Ms. Elliott, Human Resources Director, approached Mayor and Council. Ms. Elliott emphasized the important of a yearly Cost of Living Adjustments and Merit Increases as this is a way the City will not fall behind in the future. Mr. Branigin stated it is more important to emphasis a consistent Merit Program to reward the staff you really want to retain. Mr. Parks stated it is his understanding in January 2021, roughly \$109,000 and July 1, 2021 another \$109,000 which covers the next budget cycle and \$130,000 in January 2022. Dr. Gillen clarified in January 2021 and for the remainder of the current fiscal year there is \$108,000 impact. July 1, 2021 there is another \$108,000 adjustment to the budget, which is cumulative. Mr. Branigin confirmed the cost to bring the Public Safety Staff to where they need to be is approximately \$217,000 and the budgetary impact has been split into this budget cycle and next budget cycle but if the City does not implement a merit program for the 2022 budget cycle the City is already falling behind. There was a discussion regarding an evaluation plan by Dr. Gillen. Mr. Parks expressed his concerns with employees being promoted and their salary is less than in their previous position and a policy review needs to be completed. Dr. Gillen confirmed. Mr. Parks asked Dr. Gillen when Mayor and Council could expect a policy. Dr. Gillen responded it would be done parallel to the implementation of the proposed plan. Mr. Parks asked Dr. Gillen for an exact date as without that there will be no progress. Dr. Gillen responded if need clarity on the policy Mr. Parks is speaking of. He continued, there needs to be a (1) Merit Plan that is approved by Mayor and Council; (2) develop a form for the employee evaluation; and (3) ensure management has reviewed promotion policies. He will work with Ms. Elliott to develop a policy and bring to Mayor and Council at the December 10, 2020 meeting. Ms. Elliott stated some "policies" are written as ordinances and will need to be changed to an actual policy rather than ordinance. Mayor Sessions confirmed Dr. Gillen will bring back the policy at the December 2020 meeting. Dr. Gillen confirmed. He asked Mayor and Council to accept the recommendation as presented by Evergreen and the implementation timeframe. **Monty Parks** made a motion to approve the recommendations as presented. **Barry Brown** seconded. Vote was unanimous, 6-0.

Consideration of Ordinances, Resolutions

First Reading, 2020-20, Noise Ordinance. **Mr. Hughes** stated Section 4 as it deals with the beach and parks is not to be considered as part of the proposal before Mayor and Council tonight. He continued this was before Mayor and Council two weeks ago and with the concept of moving

from the decibel readers to plainly audible standards has been discussed since 2008. There have been arguments that a meter reading is not enforceable. Dr. Gillen confirmed the problematic readings of the decibel as it does not pick up all the sound waves. The proposed ordinance has the flexibility for distance and times. The current status is 300 feet from 7:00AM until 11:00PM and 100 feet from 11:00PM to 7:00AM. Mr. Hughes continued that the distances involved are still being considered. The concept that was plainly audible being adequately specific from a constitutional standpoint was upheld by the Georgia State Supreme Court with Athens/Clarke County which is the model for which is before Mayor and Council. The difference is uses abutting residential uses and is made to include other residential abutting residential due to the concept of STVR's. This is for 11:00PM to 7:00AM as it is for sound making devices restricted within those hours. He is asking for recommendations from Mayor and Council. Mr. Hughes feels the advantage to the plainly audible standard is the noise must be identified apart from the ambient noise that is going on in the neighborhood. Dr. Gillen stated for enforcement, the officer would go to the complainant's property and measure the decibel level from the property and if above a certain level then there is a violation. This will include a citation. Mayor Sessions asked the fee for the citation. Dr. Gillen confirmed it is consideration an administrative fine, \$300.00. If the ticket is written by a TIPD rather than Code Enforcement the fine could be up to \$1,000. Mr. Branigin stated the Public Safety Committee has been reviewing the situation for two years and the consensus was the plainly audible reading is better than the decibel reading approach. Their main concerns includes STVR's and may not have been fair to commercial properties. He would recommend taking out the commercial so it be only be property residential bordering residential which would include no mechanical music between the hours of 11:00PM and 7:00AM Sunday through Thursday and midnight to 7:00AM Friday and Saturday. Specific items includes: (1) under Exceptions: include an exception for generator used in conjunction with a power outage; (2) the 300' restriction and the 100' restrictions on the Sunday through Thursday should be lowered to 10:00PM rather than 11:00PM; and (3) under Equipment: Use Restrictions: this prohibits equipment such as power tools from being used between the hours of 8:00PM and 7:00AM Monday through Friday, he would recommend adding the word sunset to 7:00AM is more fair so people who are working in the highest heat of the day can still get in the reasonable amount of work. Mr. Parks stated his main concern as it relates to STVR's, the mechanical music within the residence was not working. He also recommended there should be a meeting to include the TIPD and businesses to discuss not only mechanical music but commercial music as well. **Motion: John Branigin** made a motion to accept the proposed ordinance to include the amendments he offered and dropping the beaches and parks as described by Mr. Hughes. **Monty Parks** seconded. Vote was unanimous to approve to include amendments, 6-0. **Discussion: Jay Burke** stated he is in favor and confirmed the commercial is not being addressed. Mr. Branigin confirmed and would reword, the distant restrictions would still apply but not mandating that commercial be inside the enclosed space and would apply to residential bordering residential, basically houses.

First Reading, 2020-21, Alcohol Restrictions. Jay Burke recused himself due to his occupation. Mayor Sessions referred to Mr. Hughes in regards to the recusal, according the way the Ethics Ordinance is written he does not feel anyone has a true disqualifying conflict including Mr. Burke. If others feel uncomfortable where they cannot be objective, they can also recuse themselves without being considered an abstention. As Mr. Burke is recusing due on ethical grounds under the rule then it would not be an abstention for an affirmative vote. Mr. Branigin made a motion to table the proposed agenda item until November 12, 2020. He stated his reasoning is (1) at the last council meeting, October 22, 2020, Jen Knox came forward and indicated the businesses that she had spoken to wanted to meet with the City and the TIPD, listen to the concerns and offer suggestions on how they might help with the problem. The meeting did not take place. The businesses were not given the chance to offer their opinions or

any solutions and (2) as what is in front of Mayor and Council has not been discussed with any of the bars and businesses nor based on any real discussion with Mayor and Council. Mr. Branigin continued, the City Attorney was asked to write an ordinance, he did, and it was not publically available until Friday, October 16, 2020. With not talking to the businesses and no discussions and his opinion, when Mayor and Council are doing a first reading of a proposed ordinance, it should be in a form that this close to what Mayor and Council intend to adopt. He feels what is before Mayor and Council is not close to what will be adopted. Mr. Branigin stated we need to meet with the businesses, get their ideas and then come back with a fulsome discussion so everyone has the same goal. **Spec Hosti** seconded. Those voting in favor of the motion were John Branigin and Spec Hosti. Those voting against were Monty Parks, Barry Brown, and Nancy DeVetter. Motion fail with a vote of 2-3. Mr. Parks stated the season is continuing due to COVID and the STVR's are still fully booked. He expressed his concerns with the safety of TIPD. **Monty Parks** made a motion (1) no open containers on beach from 14th to Alley 3 at all times (24/7); (2) no open containers in the public parking lots, namely the Strand, 14th and North Beach at all times (24/7); and (3) no open containers in the designated Festival Zone from 10:00PM to 8:00AM Sunday thru Thursday and from 11:00PM to 8:00AM Friday and Saturday nights. **Barry Brown** seconded. Voting in favor were Monty Parks, Barry Brown and Nancy DeVetter. **Discussion: Ms. DeVetter** stated it is important to have the meetings with the businesses so there is understanding moving forward. Voting against were John Branigin and Spec Hosti. Motion approved, 3-2. Mayor Sessions repeated the vote and stated Jay Burke has rescued himself.

Second Reading: Retirement Ordinances/Amended Plan. **Dr. Gillen** stated this agenda item is the early retirement piece and is a change to the Retirement Plan to allow for those early retirements, to get full benefits at an earlier age and it takes an ordinance to move forward. This is the second reading. He stated the other part is a financial incentive which is separate from this which has already been approved by Mayor and Council. The last day for Staff to opt in is December 9, 2020. **Monty Parks** made a motion to approve. **John Branigin** seconded. Vote was unanimous to approve 6-0.

Council, Officials and City Attorney Considerations and Comments

Bubba Hughes stated he will defer the discussion regarding **Alcohol License Fees** to a later date.

Shawn Gillen stated he will defer the discussion regarding **Beach Litter** to a later date.

Shawn Gillen stated he would like to bring back the discussion regarding **Zones/Ordinance on the Beach** until November 12, 2020. At that time he will have the maps as requested by Mayor and Council. He asked Mayor and Council to think about discussions regarding fishing designated areas; surfing designated areas; and signage. Monty Parks recommended Dr. Gillen reach out to Allen Robertson to coordinate with DNR regarding additional signage. Dr. Gillen confirmed.

Shawn Gillen stated he would like direction regarding making **Izlar and TS Chu Public Streets**. **Dr. Gillen** stated in the past the residents and businesses on Izlar and TS Chu have been to Mayor and Council to have those roads made public in that way the City can maintain. These streets are heavily used and as it is a private road they are responsible for repairs. He recommended the City move forward with making these two street public as they are heavily used. Mayor pro tem Brown asked Dr. Gillen if he has received signatures from those who do live on the two streets. Dr. Gillen stated no. Mayor pro tem Brown stated none of the infrastructure has been changed for years and there would be significant charge to bring them up to Code. Dr. Gillen responded the City would absorb the storm water cost and the paving

costs. Mayor Sessions gave a brief outline of her past experiences with TS Chu as she used to live on the street. Mr. Hughes recommended the City get estimates on how much it would cost to add new infrastructure, water lines and sewer lines. Dr. Gillen confirmed.

Monty Parks made a motion to adjourn. **John Branigin** seconded. Vote was unanimous to approve, 6-0.

Meeting adjourned at 10:00PM.

Janet R. LeViner, MMC
Clerk

File Attachments for Item:

2. Notes, City Council Workshop October 29, 2020

City Council Workshop Notes, October 29, 2020

Mayor Sessions called the workshop to order at 6:30PM. Those in attendance were Nancy DeVetter, Monty Parks, John Branigin, Barry Brown and Spec Hosti. Also attending were City Attorney's Bubba Hughes and Tracy O'Donnell; Shawn Gillen, City Manager; and Jan LeViner, Clerk of Council. Jay Burke was not in attendance as he recused himself from the previous discussion on October 22, 2020.

Mayor Sessions stated the purpose of the workshop is to discuss the proposed Alcohol Restrictions Ordinance. She stated there would be another public meeting, City Council Meeting on November 12, 2020, where the proposed ordinance could be discussed. Mayor Sessions asked Dr. Gillen to update council. Dr. Gillen stated there was a zoom meeting regarding the proposed Alcohol Restrictions and one regarding the proposed Noise Ordinance. The common thread regarding the proposed Alcohol Restriction was it is not the right time to put in place due to the pandemic as to go orders have kept businesses going and not in favor of having a ban at all. They would also like to slow the process down and allow for discussions.

Mr. Branigin: Two separate issues:

- Excessive use of alcohol during the day
- Over consumption at night.

Ms. DeVetter: Need to define the problem and stay a family friendly Island.

Mr. Hosti: Need to think it through and how it will affect the businesses.

Chief Bryson: Is in favor of island wide ban of alcohol.

Mr. Parks: Recommended:

- Committee to be formed by November 12, 2020
- Recommend each council member nominate two people to serve on committee
 - Resident
 - Business owner
- Chaired by Dr. Gillen
- Sixty (60) day time frame
- Police to be present to provide data
- Mr. Hughes to attend and advise
- Meetings to be public
- This is to further define and support the current situation with statistics to supply alternative solution to this situation
- In favor of making at motion at the November 12, 2020 meeting to table second reading of proposed ordinance

Dr. Gillen: will have committee set on November 12, 2020 which will be public forums

Ms. DeVetter: Recommended non-profits be included in discussions

Mayor Sessions:

- Demery Bishop to be involved as be an ex-officio
- Bring recommendations to Mayor and Council, January 28, 2021.
- As Mr. Burke recused, he may not be involved in discussions and in nominating individuals to sit on meeting

No further business. Workshop adjourned at 7:18PM.

Jan Leviner, MMC
Clerk of Council

File Attachments for Item:

4. Text Amendment: Sec. 3-190 Swimming pool requirements.



STAFF REPORT

PLANNING COMMISSION MEETING: October 19, 2020

CITY COUNCIL MEETING: November 12, 2020

LOCATION: N/A

APPLICANT: City of Tybee Island

OWNER: N/A

EXISTING USE: N/A

PROPOSED USE: N/A

ZONING: N/A

USE PERMITTED BY RIGHT: N/A

COMMUNITY CHARACTER MAP: N/A

APPLICATION: Amendment to Article 3-190, Swimming pool requirements and placement.

PROPOSAL: To require that the initial fill and subsequent significant refills of a swimming pool be done with water from an off island source.

ANALYSIS: This amendment will reduce water withdrawal from the City's system. Staff could find no local source for this service.

STAFF FINDING

This amendment will save approximately 5,000 to 10,000 gallons of water withdrawal from the City's system for each new pool built.

This Staff Report was prepared by George Shaw.

ATTACHMENTS

- A. Amendment



**CITY OF TYBEE ISLAND
LAND DEVELOPMENT CODE
TEXT AMENDMENT APPLICATION**

Fee \$500

Applicant's Name CITY OF TYBEE ISLAND

Applicant's Telephone Number 912-472-5031

Applicant's Mailing Address P.O. Box 2749, TYBEE ISLAND, GA 31328

If within two (2) years immediately preceding the filing of the Applicant's application for a zoning action, the Applicant has made campaign contributions aggregating to more than \$250 to the Mayor and any member of Council or any member of the Planning Commission, the Applicant and the Attorney representing the Applicant must disclose the following:

- a. The name of the local government official to whom the campaign contribution or gift was made;
- b. The dollar amount of each campaign contribution made by the applicant to the local government official during the two (2) years immediately preceding the filing of the application for this zoning action, and the date of each contribution;
- c. An enumeration and description of each gift having a value of \$250 or more made by the Applicant to the local government official during the two (2) years immediately preceding the filing of the application for this zoning action.

Disclosure of Campaign Contributions form attachment hereto: Yes

 9-11-2020
 Signature of Applicant Date

NOTE: Other specific data is required for each proposed Text Amendment.

City Official _____ Date _____

Item #4.

NOTE: This application must be accompanied by additional documentation, including drawings and/or text that include or illustrate the information outlined below.

Indicate in the spaces provided whether or not the required information is provided.

<u>YES or NO</u>	<u>REFERENCE</u>	<u>DESCRIPTION</u>
<u>Y</u>	5-020 (E)	An amendment to the text of this Land Development Code follows the same process as an amendment to the zoning map. However, a text amendment requires different materials to be included with the application.
<u>Y</u>	5-040 (E) (1)	In the case of a text amendment, the application shall set forth the new text to be added and the existing text to be deleted.
	5-110	Section 5-110, Standards for Land Development Code or Zoning Map Amendment Approval, identifies standards and other factors to be considered by the Mayor and Council in making any zoning decision. The Applicant should provide written data addressing each of the below listed standards and factors to assure consideration of applicable information.
<u>N</u>	5-110 (A)	The existing land use pattern;
<u>N</u>	5-110 (B)	The possible creation of an isolated district unrelated to adjacent and nearby districts;
<u>N</u>	5-110 (C)	The existing population density pattern and the possible increase or overtaxing of the load on public facilities;
<u>N</u>	5-110 (D)	Whether changed or changing conditions make the passage of the proposed amendment reasonable;
<u>N</u>	5-110 (E)	Whether the proposed change will adversely influence existing conditions in the neighborhood or the city at large;
<u>N</u>	5-110 (F)	Potential impact on the environment, including but not limited to drainage, soil erosion and sedimentation, flooding, air quality, and water quality and quantity;
<u>N</u>	5-110 (G)	The reasonableness of the costs required of the public in providing, improving, increasing or maintaining public utilities, schools, streets and public safety necessities when considering the proposed changes;
<u>N</u>	5-110 (H)	Whether the proposed change will be detrimental to the value or improvement or development of adjacent or nearby property in accordance with existing requirements;
<u>N</u>	5-110 (I)	Whether the proposed change is out of scale with the needs of the neighborhood or entire city;
<u>N</u>	5-110 (J)	Whether the proposed change will constitute a grant of special privilege to the individual owner as contrasted with the adjacent or nearby neighborhood or with the general public; and,
<u>N</u>	5-110 (K)	The extent to which the zoning decision is consistent with the current city master plan or other local planning efforts, if any, of the city.

The Applicant certifies that he/she has read the requirements for Land Development Code Text Amendments and has provided the required information to the best of his/her ability in a truthful and honest manner.



 Signature of Applicant

9-16-2020

 Date



CITY OF TYBEE ISLAND

CONFLICT OF INTEREST IN ZONING ACTIONS
DISCLOSURE OF CAMPAIGN CONTRIBUTIONS

Have you within the past two (2) years made campaign contributions or gave gifts having an aggregate value of \$250.00 or more to a member of the City of Tybee Island Planning Commission, or Mayor and Council or any local government official who will be considering the rezoning application?

YES _____ NO X _____

IF YES, PLEASE COMPLETE THE FOLLOWING SECTION:

NAME OF GOVERNMENT OFFICIAL	CONTRIBUTIONS OF \$250.00 OR MORE	GIFTS OF \$250.00 OR MORE	DATE OF CONTRIBUTION

IF YOU WISH TO SPEAK CONCERNING THE ATTACHED REZONING APPLICATION, THIS FORM MUST BE FILED WITH THE ZONING ADMINISTRATOR FIVE (5) DAYS PRIOR TO PLANNING COMMISSION MEETING IF CAMPAIGN CONTRIBUTIONS OR GIFTS IN EXCESS OF \$250.00 HAVE BEEN MADE TO ANY MEMBER OF THE PLANNING COMMISSION OR MAYOR AND COUNCIL.

Signature George B. Skau

Printed Name George B. Skau

Date 9-11-2020

ORDINANCE NO. 2020 _____

AN ORDINANCE TO AMEND THE CODE OF ORDINANCES SECTION 3-190 SWIMMING POOL REQUIREMENTS AND PLACEMENT SO AS TO IMPOSE A REQUIREMENT THAT WATER TO BE APPLIED TO A NEWLY CONSTRUCTED POOL OR A POOL THAT RECEIVES MAJOR RENOVATIONS CONSISTING OF MORE THAN TWENTY-FIVE PERCENT OF THE POOL BASED ON THE VOLUME OF WATER SHALL BE FILLED FROM OR BY AN OUTSIDE WATER SOURCE RATHER THAN THE CITY'S MUNICIPAL WATER SYSTEM

WHEREAS, the duly elected governing authority for the City of Tybee Island, Georgia, is authorized under Article 9, Section 2, Paragraph 3 of the Constitution of the State of Georgia to adopt reasonable ordinances to protect and improve the public health, safety, and welfare of the citizens of Tybee Island, Georgia, and

WHEREAS, the duly elected governing authority for the City of Tybee Island, Georgia, is the Mayor and Council thereof; and

WHEREAS, the governing authority desires to adopt ordinances under its police and home rule powers; and

WHEREAS, the City of Tybee Island has approached and does approach its withdrawal capacity from the Floridan Aquifer; and

WHEREAS, the City has been expecting to have a deep well constructed on the island however, due to a failure of the structure during construction the well has not been built; and

WHEREAS, in order to protect the resources of the City and to continue to establish or promote principles of conservation, the Mayor and Council have determined that the Code of Ordinances of the City of Tybee Island should be amended so as to address the use of water in connection with privately constructed swimming pools.

NOW, THEREFORE, it is hereby ordained by the governing authority of the City of Tybee Island as follows:

SECTION I

Section 3-190 shall be amended to add a new subsection "(H) water restriction" which shall read as follows:

 **(H) Water Restriction**

For the initial filling of a newly constructed swimming pool, the water to fill the pool shall be from an outside source and not from the City's municipal water system. Further; when due to repair, malfunction or renovation of a pool, whether now existing or hereafter constructed, the addition of twenty-five percent or more of the ordinary capacity of the swimming pool requires refilling, such refilling, "capping" or topping off shall be accomplished by water from an independent water source other than the City's municipal water system.

SECTION 2

All ordinances and parts of ordinances in conflict herewith are expressly repealed.

SECTION 3

It is the intention of the governing body, and it is hereby ordained, that the provisions of this ordinance shall become effective and be made a part of the Code of Ordinances, City of Tybee Island, Georgia, and the sections of this ordinance may be renumbered to accomplish such intention.

SECTION 4

This ordinance shall be effective upon its adoption by the Mayor and Council pursuant to The Code of the City of Tybee Island, Georgia.

This Ordinance shall become effective on _____ day of _____, 2020.

ADOPTED THIS ____ DAY OF _____, 2020.

MAYOR

ATTEST:

CLERK OF COUNCIL

FIRST READING: _____

SECOND READING: _____

ENACTED: _____



**PLANNING COMMISSION
NOTICE OF DETERMINATION**

Meeting date: September 21, 2020

Project Name/Description: Text Amendment

Action Requested: Sec. 3-190 Swimming pool requirements.

Special Review	Subdivision: Sketch Plan Approval ___ Conceptual ___ Preliminary Plan Approval ___ Final Plat Approval ___ Minor Subdivision ___ Major Subdivision ___
Site Plan Approval	
Variance	
Map Amendment	
Text Amendment X	

Petitioner has met all documentation requirements, all external approval requirements, and all code requirements, except for the following:

The Planning Commission Motion on Petition: Approval Denial Continued

Action on Motion:

COMMISSIONER	FOR	AGAINST	COMMENTS
Bishop			Chair
Bossick	X		Vice Chair - Motion
Matlock	X		
McGruder	X		Second
McNaughton	X		
Reynolds	X		
Robertson			Absent

Planning Commission Chair: 

Date: 7/28/2020

Planning & Zoning Manager: 

Date: 9-23-2020

Pool Water Delivery & Bulk Water Delivery Companies Located in: GA

Below are the bulk water hauling and pool water delivery companies for the state you selected.

Georgia Bulk/Pool Water Hauling Companies [Company Not Listed, Add Your Listing](#)

Number of Bulk/Pool Water Hauling Companies Found: 5

Dive In Inc.

Atlanta, GA

Phone: [404-254-1616](#)

Roberts Pool Works

ForestPark, GA

Phone: [404-906-9552](#)

Tony's Water Service

Homer, GA

Phone: [706-677-2463?](#)

Abu Water Service

Lagrange, GA

Phone: [706-882-5835](#)

Amicalola Services Llc

Tate, GA

Phone: [770-894-3182](#)



**PLANNING COMMISSION
NOTICE OF DETERMINATION**

Meeting date: October 19, 2020

Project Name/Description: Text Amendment

Action Requested: Sec. 3-190 Swimming pool requirements

Special Review		Subdivision:	
Site Plan Approval		Sketch Plan Approval	___ Conceptual ___
Variance		Preliminary Plan Approval	___
Map Amendment		Final Plat Approval	___
Text Amendment	X	Minor Subdivision	___ Major Subdivision ___

Petitioner has met all documentation requirements, all external approval requirements, and all code requirements, except for the following:

The Planning Commission Motion on Petition: Approval Denial Continued

Action on Motion:

COMMISSIONER	FOR	AGAINST	COMMENTS
Bishop			Chair
Bossick	X		Vice Chair
Matlock		X	
McGruder	X		
McNaughton	X		
Reynolds			Absent
Robertson	X		

Planning Commission Chair:  Date: 11/4/2020

Planning & Zoning Manager:  Date: 10-30-2020

ORDINANCE NO. 2020 _____

AN ORDINANCE TO AMEND THE CODE OF ORDINANCES SECTION 3-190 SWIMMING POOL REQUIREMENTS AND PLACEMENT SO AS TO IMPOSE A REQUIREMENT THAT WATER TO BE APPLIED TO A NEWLY CONSTRUCTED POOL OR A POOL THAT RECEIVES MAJOR RENOVATIONS CONSISTING OF MORE THAN TWENTY-FIVE PERCENT OF THE POOL BASED ON THE VOLUME OF WATER SHALL BE FILLED FROM OR BY AN OUTSIDE WATER SOURCE RATHER THAN THE CITY'S MUNICIPAL WATER SYSTEM

WHEREAS, the duly elected governing authority for the City of Tybee Island, Georgia, is authorized under Article 9, Section 2, Paragraph 3 of the Constitution of the State of Georgia to adopt reasonable ordinances to protect and improve the public health, safety, and welfare of the citizens of Tybee Island, Georgia, and

WHEREAS, the duly elected governing authority for the City of Tybee Island, Georgia, is the Mayor and Council thereof; and

WHEREAS, the governing authority desires to adopt ordinances under its police and home rule powers; and

WHEREAS, the City of Tybee Island has approached and does approach its withdrawal capacity from the Floridan Aquifer; and

WHEREAS, the City has been expecting to have a deep well constructed on the island however, due to a failure of the structure during construction the well has not been built; and

WHEREAS, in order to protect the resources of the City and to continue to establish or promote principles of conservation, the Mayor and Council have determined that the Code of Ordinances of the City of Tybee Island should be amended so as to address the use of water in connection with privately constructed swimming pools.

NOW, THEREFORE, it is hereby ordained by the governing authority of the City of Tybee Island as follows:

SECTION I

Section 3-190 shall be amended to add a new subsection "(H) water restriction" which shall read as follows:

(H) Water Restriction

For the initial filling of a newly constructed swimming pool, the water to fill the pool shall be from an outside source and not from the City's municipal water system. ~~Further, when due to repair, malfunction or renovation of a pool, whether now existing or hereafter constructed, the addition of twenty five percent or more of the ordinary capacity of the swimming pool requires refilling, such refilling, "capping" or topping off shall be accomplished by water from an independent water source other than the City's municipal water system.~~

SECTION 2

All ordinances and parts of ordinances in conflict herewith are expressly repealed.

SECTION 3

It is the intention of the governing body, and it is hereby ordained, that the provisions of this ordinance shall become effective and be made a part of the Code of Ordinances, City of Tybee Island, Georgia, and the sections of this ordinance may be renumbered to accomplish such intention.

SECTION 4

This ordinance shall be effective upon its adoption by the Mayor and Council pursuant to The Code of the City of Tybee Island, Georgia.

This Ordinance shall become effective on _____ day of _____, 2020.

ADOPTED THIS ____ DAY OF _____, 2020.

-

MAYOR

ATTEST:

CLERK OF COUNCIL

FIRST READING: _____

SECOND READING: _____

ENACTED: _____

File Attachments for Item:

5. Approval of itemized list of budget amendments to the 2021 City budget to include specific explanations for the budget amendments. In total, the general fund budget expenditures will increase \$562,055.



City of Tybee Island

Memorandum

To: City Council
From: Jen Amerell, Finance Director *JRA*
Date: October 26, 2020
Re: 2021 Budget Amendments

Overview

Attached please find an itemized list of budget amendments to the 2021 City budget, as well as specific explanations for the budget amendments. In total, the general fund budget expenditures will increase \$562,055.

The total increase is offset by a decrease in other general fund expenditures, as well as an increase in both recycling revenue and expected property tax revenue. The remaining balance of expenditure increases will be financed by general fund balance.

The primary sources for current budget amendments:

- Leases for TIPD – with a freeze on capital purchases in the 2021 budget, the vehicle leases were not included in the operating budget and should be
- Equipment requirements for additional Code Compliance approved by Council
- COVID-19 related equipment & materials – these expenses may be eligible for reimbursement from State, however 2nd round of CARES funding has not been announced yet

Recommendation

Approve budget amendments as indicated on attached budget amendment summary.

**CITY OF TYBEE ISLAND, GEORGIA
BUDGET LINE ITEM TRANSFER REQUEST FORM**



Item #5.
Submitted By: Finance

Date: 10/27/2020

Purpose: Budget amendment requests for FY2021

Date Received by Finance: _____
FINANCE USE ONLY
BA Ref No. _____

Department	Account Description	Account Number	Current Budget	Budget Balance	Requested Budget Adjustment	Adjusted Budget Balance
Rev	Recycling Revenue	100-00-34-4130	0.00	0.00	3,000.00	3,000.00
Rev	Property Tax	100-00-31-1100	1,900,000.00	1,900,000.00	90,000.00	1,990,000.00
	Fund Balance	100-00-39-1300	0.00	0.00	384,750.00	384,750.00
SUBTOTAL LINE ITEM DECREASES:					\$ -	\$ 477,750.00

Department	Account Description	Account Number	Current Budget	Budget Balance	Requested Budget Adjustment	Adjusted Budget Balance
REVENUE LINE ITEM CHANGES						
Clerk	Contract Services	100-1320-52-1300	69,000.00	69,000.00	11,300.00	80,300.00
DPW	Machinery & Equip - Sweeper	100-4210-54-2100	60,000.00	60,000.00	59,305.00	695.00
DPW	Street Sweeper Principal	100-4210-58-1200	0.00	0.00	43,603.00	43,603.00
DPW	Street Sweeper Interest	100-4210-58-2200	0.00	0.00	2,502.00	2,502.00
DPW	Service Fee	100-4210-52-3900	0.00	0.00	13,200.00	13,200.00
Council	Property/Liability	100-1110-52-3100	0.00	0.00	25,000.00	25,000.00
DPW	Property/Liability	100-4210-52-3100	71,000.00	71,000.00	7,000.00	78,000.00
WS	Property/Liability	505-4350-52-3100	76,000.00	76,000.00	13,000.00	89,000.00
Camp	Property/Liability	555-6180-52-3100	10,000.00	10,000.00	10,000.00	20,000.00
Finance	Travel & Related	100-1510-52-3500	13,000.00	13,000.00	10,000.00	3,000.00
Finance	Education & Training	100-1510-52-3700	20,000.00	20,000.00	15,000.00	5,000.00
IT	Dues & Fees	100-1535-52-3600	0.00	0.00	1,800.00	1,800.00
TIPD	Small Equipment	100-3210-53-1616	26,000.00	26,000.00	27,500.00	53,500.00
TIPD	Leased Vehicle Program	100-3210-52-2321	0.00	0.00	100,000.00	100,000.00
TIPD	Machinery & Equipment	100-3210-54-2100	0.00	0.00	93,300.00	93,300.00
TIFD	Postage & Freight	100-3510-52-3220	250.00	250.00	2,300.00	2,550.00
TIFD	Machinery & Equipment	100-3510-54-2100	0.00	0.00	30,000.00	30,000.00
TIFD-EM	Emer Mgt Maint/Repairs Bldgs	100-3510-52-2204	0.00	0.00	20,000.00	20,000.00
TIFD-EM	Emer Mgt Supplies & Materials	100-3510-53-1104	0.00	0.00	8,000.00	8,000.00
TIFD-EM	Emer Mgt Small Equipment	100-3510-53-1604	0.00	0.00	8,000.00	8,000.00
DPW	Vehicles	100-4210-54-2200	0.00	0.00	30,000.00	30,000.00
DPW	Machinery & Equipment	100-4210-54-2100	0.00	0.00	9,300.00	9,300.00
DPW	Infrastructure	100-4210-54-1410	0.00	0.00	60,000.00	60,000.00
DPW	Infrastructure	100-4210-54-1410	0.00	0.00	27,750.00	27,750.00
HR	Contract Services- Class/Comp	100-1540-52-1325	0.00	0.00	9,900.00	11,900.00
H	Training	100-1540-52-3725	2,000.00	2,000.00	600.00	1,200.00
H	Dues & Fees	100-1540-52-3600	600.00	600.00	0.00	0.00
SUBTOTAL LINE ITEM INCREASES:					\$ 84,305.00	\$ 562,055.00

Archives to Secure Records Solutions
 Offset cost of Street Sweeper
 Street Sweeper
 Street Sweeper
 Street Sweeper
 Additional funds needed for FY21
 Additional funds needed for FY21
 Additional funds needed for FY21
 Additional funds needed for FY21
 Offset cost of additional expenses
 Offset cost of additional expenses
 GMA Telecom Management Svcs
 Radios for Code Enforcement
 Lease for TIPD moved to capital budget
 AXON TAP(55,400) Fleet Cameras (26,500) CE(11,400)
 Freight charges for life guard stands
 Clubcar Carryall Diesel Replacement Vehicles
 Ionization Units
 Covid Related, may be reimbursed
 Covid Related, may be reimbursed
 Wrecker Tow Truck purchased Aug 20
 Tractor
 Irrigation Repair
 Electrical Upgrade, benches, garbage cans
 Class and Comp Study
 Cornerstone Training
 Background checks for new employees

Net Change \$ (84,305.00) \$ (84,305.00) \$

File Attachments for Item:

6. Professional Services Agreement with Goodwyn Mill and Cawood, Inc.

**PROFESSIONAL SERVICES AGREEMENT between
The CITY OF TYBEE ISLAND, GEORGIA and GOODWYN MILL AND
CAWOOD, INC.**

THIS IS AN AGREEMENT made this _____ day of _____ 2020 between the City of Council of Tybee Island, Georgia, a political subdivision of the State of Georgia, (“CITY”) and Goodwyn Mills and Cawood, Inc., (GMC) an Alabama corporation, (“CONSULTANT”). The CITY wishes to engage CONSULTANT to provide professional consulting services to assist the CITY with compliance related to its National Pollutant Discharge Elimination System (NPDES) Phase I Municipal Separate Storm Sewer System (MS4) Medium Permit. The following summarizes the contents of this AGREEMENT:

- Section 1.0 – General Considerations
- Section 2.0 – CITY Responsibilities
- Section 3.0 – CONSULTANT Responsibilities
- Section 4.0 – Project Scope of Services and Schedule Summary
- Section 5.0 – Project Budget and Payments to CONSULTANT

1.0 SECTION 1.0 – GENERAL CONSIDERATIONS

- 1.1 **Commencement.** Upon execution of this AGREEMENT, the CONSULTANT shall enter into a contract with the CITY for the services specified herein. The CONSULTANT recognizes that timely, quality service will be essential to complete this project and the services contemplated under this AGREEMENT. This AGREEMENT will take effect upon delivery of executed AGREEMENT to both parties.
- 1.2 **Term of AGREEMENT.** The initial term of this AGREEMENT shall end on May 15, 2020, or upon submittal of the NPDES Phase I MS4 Annual Report to the Georgia Environmental Protection Division, whichever is later. The term of the AGREEMENT may be modified upon mutual consent of both parties.
- 1.3 **Termination of AGREEMENT.** Either party, upon giving 30 days written notice, may terminate this AGREEMENT at any time without cause. Termination of this AGREEMENT by either party shall not impair or affect whatever rights, including payment for services performed prior to termination either party may have under this AGREEMENT. Further, if the CONSULTANT fails to fulfill its contractual obligations as specified herein, the CITY may, by giving written notification to the CONSULTANT, terminate the AGREEMENT for such default. If the AGREEMENT is so terminated, the CONSULTANT shall be paid only for the work satisfactorily completed.
- 1.4 **Successors and Assigns.** CITY and CONSULTANT each is hereby bound and the partners, successors, executors, administrators, assigns and legal representatives of each are bound, to the other party to this AGREEMENT and to the partners, successors, executors, administrators, assigns and legal representatives of such other party, in respect to all covenants, agreements and obligations of this AGREEMENT. Neither CITY nor CONSULTANT shall assign, sublet or transfer any rights under or interest in (including,

but without limitation, moneys that may become due or moneys that are due) this AGREEMENT without the written consent of the other. Nothing herein shall be construed to give any rights or benefits hereunder to anyone other than CITY and CONSULTANT.

- 1.5 **License, Permits and Taxes.** The CONSULTANT shall be responsible for all applicable licenses, permits and taxes incurred during the performance of this AGREEMENT.
- 1.6 **Indemnification and Hold Harmless.** The CONSULTANT shall indemnify and hold the CITY and its officers, agents, employees and assigns, harmless from any liability imposed for injury arising during the completion of work outlined in this AGREEMENT, or in any manner directly or indirectly caused, occasioned or contributed to, in whole or in part, by reason of a negligent act or omission, including strict liability or negligence of CONSULTANT, or of anyone acting under the CONSULTANT's direction or control or on its behalf, in connection with this AGREEMENT.
- 1.7 **Limits of Liability.** In recognition of the relative risks, rewards and benefits of the project to both the CITY and CONSULTANT, the risks have been allocated such that CONSULTANT and the CITY agree that, to the fullest extent permitted by law, and notwithstanding any other provision of this Agreement, the total liability, in the aggregate, of CONSULTANT and CONSULTANT 's officers, directors, employees, agents and subconsultants, to the CITY and anyone claiming by, through or under CITY, for any and all claims, losses, costs or damages whatsoever arising out of, resulting from or in any way related to the AGREEMENT from any cause or causes, including but not limited to the negligence, professional errors or omissions, strict liability or breach of contract or warranty express or implied of CONSULTANT or CONSULTANT 's officers, directors, employees, agents or subconsultants, shall not exceed limits of professional errors and omissions liability insurance.
- 1.8 **Ownership of Project Documents and Reports.** All documents and reports prepared by the CONSULTANT pursuant to this AGREEMENT are instruments of service and shall be the joint property of the CITY and CONSULTANT upon completion. The CITY may reproduce and distribute these documents to appropriate parties; however, certain documents may not be suitable for re-use by the CITY on other project(s) without proper consultation with the CONSULTANT. The CONSULTANT may use the work product developed under this AGREEMENT for future marketing and project endeavors.
- 1.9 **Discovery of Unanticipated Hazardous Materials.** Hazardous materials may exist where there is no reason to believe they could or should be present. The client acknowledges that CONSULTANT's scope of services for this project does not include any services related to hazardous wastes. CONSULTANT and the CITY agree that the discovery of unanticipated hazardous materials constitutes a changed condition mandating a renegotiation of the scope of work or termination of services. CONSULTANT and the CITY also agree that the discovery of unanticipated hazardous materials may make it necessary for CONSULTANT to take immediate measures to protect human health and safety, and/or the environment. CONSULTANT agrees to notify the CITY as soon as practically possible should unanticipated hazardous materials or suspected hazardous

materials be encountered. The CITY encourages CONSULTANT to take any and all measures that in CONSULTANT's professional opinion are justified to preserve and protect the health and safety of CONSULTANT's personnel and the public, and/or the environment, and the CITY agrees to compensate CONSULTANT for the additional cost of such work.

- 1.10 **CITY Disclosure.** CITY agrees (on an ongoing basis) to advise CONSULTANT of any hazardous substance or any condition, known or that reasonably should be known by CITY, existing in, on, or near the site that presents a potential danger to human health, the environment, or CONSULTANTS equipment. CONSULTANT does not assume control of the site or undertake responsibility for reporting to any federal, state or local public agencies any conditions at the site that may present a potential danger to public health, safety or the environment or that may otherwise be required by applicable law, rule or regulation, all of which is the CITY's responsibility.

- 1.11 **Controlling Law.** This AGREEMENT is to be governed by the laws of the State of Georgia. The parties hereby agree and stipulate this AGREEMENT was made and entered into in Chatham County, Georgia, which shall be appropriate venue for any action brought relating thereto. CONSULTANT shall comply with all applicable CITY, State and Federal provisions related to its performance of the work under this AGREEMENT.

- 1.12 **Severability and Reformation.** Any provision or part thereof of this AGREEMENT held to be void or unenforceable under any law shall be deemed stricken, and all remaining provisions shall continue to be valid and binding upon the parties. The parties agree that this AGREEMENT shall be reformed to replace such stricken provision or part thereof with a valid and enforceable provision which comes as close as possible to expressing the intention of the stricken provision.

- 1.13 **Non-discrimination.** CONSULTANT shall not discriminate in the employment of persons engaged in the performance of this AGREEMENT on account of race, color, national origin, ancestry, religion, sex, marital status, physical handicap, or medical condition, in violation of any federal or state law. CONSULTANT shall comply with all requirements of the CITY with regards to employment while this AGREEMENT is in effect.

2.0 SECTION 2.0 – CITY'S RESPONSIBILITIES

CITY and/or CITY Staff shall:

- 2.1 Provide all information for the project, including project objectives and constraints, performance requirements, flexibility and expendability, any budgetary limitations, copies of relevant documents and access to relevant files, software and hardware necessary to execute the work effort.

- 2.2 Promptly furnish to CONSULTANT the information requested by CONSULTANT that is needed for rendering of services defined herein. The CITY shall provide to the CONSULTANT all such information that is available to the CITY, and the

CONSULTANT shall be entitled to rely upon the accuracy and completeness thereof. The CONSULTANT recognizes that it is impossible for the CITY to assure the accuracy, completeness and sufficiency of information provided to CONSULTANT by CITY or third parties.

- 2.3 Assist CONSULTANT by placing at his disposal all available information pertinent to the project including previous reports and any other data relevant to project.
- 2.4 Undertake and perform the CITY's project related responsibilities as specified in Section 4.0 of this AGREEMENT. Allow the CONSULTANT reasonable access to designated CITY staff personnel and property related to execution of specific work tasks that the CITY staff will perform.
- 2.5 Assist/arrange for access to and make all provisions for CONSULTANT to enter upon public and private property as required for CONSULTANT to perform his services.
- 2.6 Designate a person (or persons) to act as CITY's representative(s) with respect to the management, technical and production related activities to be performed by the CITY under this AGREEMENT. Such person(s) shall have complete authority to transmit instructions, receive information, interpret and define CITY's policies and decisions with respect to materials, equipment, elements and systems pertinent to CONSULTANT's services.

3.0 SECTION 3.0 – CONSULTANT'S RESPONSIBILITIES

- 3.1 **Standard of Care.** The CONSULTANT shall manage and perform the work in accordance with applicable laws and codes. By execution of this AGREEMENT, the CONSULTANT warrants that he/she is possessed of the requisite skill and ability which is ordinarily possessed by other members of his/her profession. CONSULTANT will exercise such degree of skill and ability as is ordinarily employed by professionals who practice in the State of Georgia under similar conditions and like circumstances, and he/she shall perform such duties without neglect, and shall not be liable except for failure to exercise such appropriate degree of care, learning, skill and ability.
- 3.2 **Authorized Representative.** CONSULTANT shall designate a person (or persons) to act as CONSULTANT's representative(s) with respect to the services to be rendered under this AGREEMENT. Such person(s) shall have complete authority to transmit instructions, receive information, interpret and define CONSULTANT's policies and decisions with respect to materials, equipment, elements and systems pertinent to this AGREEMENT.
- 3.3 **Subcontracting.** The subcontractor that is approved for this project is Clearwater Solutions, Inc. The CONSULTANT shall not further subcontract any part of the work covered by this AGREEMENT, or permit subcontracted work to be further subcontracted, without the CITY'S prior approval of the subcontractor.

- 3.4 **Insurance.** The CONSULTANT shall maintain the following insurance requirements during the time of performance of the services outlined in this AGREEMENT for the contract period. An insurance certificate must be on file with the CITY Administrator's office within four weeks of the signing of the contract by both parties.
- A. General Liability Insurance, with a combined single limit of \$1,000,000 for each occurrence and \$2,000,000 in the aggregate;
 - B. Automobile Liability Insurance, with a combined single limit of \$1,000,000 for each person and \$1,000,000 for each accident;
 - C. Worker's Compensation insurance in accordance with statutory requirements, with a limit of \$500,000 for each occurrence;

4.0 SECTION 4.0 – PROJECT SCOPE OF SERVICES

The specific services which the CONSULTANT agrees to furnish and the terms the CONSULTANT agrees to follow are set forth herein. The CONSULTANT shall furnish the services to provide professional consulting services to assist the CITY with implementation of its NPDES Phase I Medium MS4 Permit.

4.1 Task 1: Update of Tybee Island NPDES Phase I Medium MS4 Stormwater Management Plan (SWMP) and Supporting Plans

GMC will coordinate a meeting to discuss the City's current SWMP and recent comments by the Georgia Environmental Protection Division (EPD), dated April 21, 2020, on the SWMP, Illicit Discharge Detection and Elimination (IDDE) Plan, Impaired Waters, Green Infrastructure/Low Impact Development (GI/LID) Plan, and Enforcement Response Plan (ERP). Our team will facilitate discussions with City staff on the City's current NPDES Phase I MS4 compliance approach, the existing SWMP, and any desired or required changes. Based on this meeting, and our experience assisting other local NPDES Phase I MS4 Permittees comply with these same requirements, we will update these documents for the City of Tybee Island. We will provide drafts of the updates to the City staff for their review and we will make updates to the drafts based on this feedback. We will work with City staff to ensure that these documents are submitted to EPD prior to the City's deadline of December 22, 2020. If there are additional comments provided by EPD on this future submittal in December of 2020, GMC can assist the City with addressing those comments as an hourly additional service.

GMC will also assist the City with preparing a written response letter to accompany the revised SWMP and associated plans that will be submitted to the Georgia EPD. This response letter will explain how the City has addressed the information and requests specified in the Georgia EPD's April 21st letter.

4.2 Task 2: Dry Weather Screening/Illicit Discharge Monitoring

Per the City's SWMP, GMC will perform Dry Weather Screening in accordance with the procedure submitted to EPD and included in the City's SWMP. GMC will also perform Dry Weather Screening in accordance with the Coastal IDDE Plan Guidelines provided by the Georgia EPD in the April 21, 2020 letter to the City of Tybee. The City should be conducting dry weather screening for about 20% of their outfalls per reporting period, so

GMC will conduct dry weather screening for 9 outfalls in the 2020-2021 reporting period. We also understand that Tybee Island did not conduct any dry weather screening during the 2019-2020 reporting period, so we will also perform another 20% or 9 additional outfalls during this reporting period.

For each MS4 Outfall, GMC staff will complete a Dry Weather Screening Form. If flow is not present, the GMC field staff will note it as such, take a photograph of the outfall, and complete the necessary sections of the form – (1) background data, (2) outfall description, and (3) physical indicators for flowing and non-flowing outfalls. If flow is present, GMC field staff will visually evaluate additional physical indicators of odor, color, turbidity, and floatables. The field staff will also measure temperature, pH, salinity, turbidity, and conductivity using a Horiba U-53 probe. The field staff will calibrate the equipment in accordance with standard protocols and also perform a factory calibration once per year, in compliance with QA/QC procedures. A fecal coliform grab sample will be taken and brought to an accredited laboratory, if the field results indicate potential sewage or when there is visual evidence including milky white or gray color and floatables, a sewage odor, or other applicable evidence of potential sanitary sewer discharge. The GMC field staff will gather all results and complete the Dry Weather Screening Forms. For outfalls where an illicit discharge is suspected, the field staff will provide the City with the location of the outfall and the sampling results, such that the City staff can initiate source tracing activities, as appropriate. If requested by the City, the GMC staff may assist with any required source tracing activities, including GIS analysis of land uses and potential sources and additional upstream water quality monitoring. (Source tracing services are considered out-of-scope and can be performed, upon request, as hourly, additional services, and charged accordingly.)

4.3 Task 3: Education, Training, and Community Outreach

GMC will assist the City with implementing their Public Education and Public Involvement BMPs outlined in their SWMP. For the relevant activities listed in the City's SWMP, GMC will assist the City by performing the following tasks, upon request from City staff:

- Provide information, links, and documents to download that can be included on the City's stormwater webpage to ensure the City complies with its annual stormwater webpage update requirement.
- Provide City with electronic versions of educational material related to industrial and highly visible pollutant sources (HVPS) facilities, so that this information can be distributed to facility managers during the City's inspection of these facilities.
- Provide support to the City for annual meeting of the Master Plan Implementation Committee (or similar meeting) that discusses stormwater issues.

GMC will also lead a training session on the NPDES Phase I SWMP with City staff, in accordance with the requirements of the NPDES Phase I MS4 permit. GMC staff will develop training materials, provide a sign-in sheet, and maintain adequate documentation for the City's Annual Report. This training session may be conducted in coordination with other NPDES permittees in Chatham County. Training materials provided by GMC may also be in the form of a video or PowerPoint presentation that the City may provide to

appropriate field and supervisory staff during staff meetings. Alternatively, GMC may provide training opportunities for Staff to attend, such as Regional Stormwater Committee meetings in combination with one or more of the previously-listed training methods.

4.4 Task 4: MS4 Inventory Update & Inspection of the Stormwater Inventory

Tybee Island is required to inspect 100% of its stormwater system before the end of the 2017-2022 permit period; in addition, the City is responsible for updating its GIS inventory. EPD has noted in its comment letter that the MS4 GIS Inventory provided in the SWMP is incomplete, and it is our understanding that Tybee Island no longer contracts with CRD to maintain or update this inventory. As such, we believe it is essential for the City to perform and update the GIS inventory of its drainage infrastructure to ensure that the City remains compliant with the NPDES Permit. This updated GIS layer will also be useful for the City's CRS submittal (as it is also a requirement of that program). Furthermore, this GIS inventory can become a tool for the City's public works department to utilize for the purposes of documenting maintenance activities.

GMC staff will perform a field update of the City's drainage infrastructure, including catch basins, pipes, ditches, and outfalls. While we are performing this GIS work, GMC staff will also perform an NPDES-compliance inspection of the City's MS4 structures inventoried, based on the procedures included in the 2017 SWMP. The inspection results will be recorded in the GIS database. GMC staff will ensure that at least 20% of the system's structures are updated through the field inventory and inspected, in order to ensure that the City meets its permit obligations.

Any maintenance or structural issues discovered in the field will be compiled, prioritized and provided to the City so that maintenance can be scheduled and performed by City personnel or their designee. GMC will provide the updated GIS database to the City in any format desired and will summarize the results for inclusion in the Annual Report.

4.5 Task 5: GI/LID Inventory & Inspections

EPD has required Tybee Island to update its inventory of GI/LID structures and to perform inspections of the GI/LID structures. GMC will update the database (prior to submittal of the GI/LID Plan to EPD in December) and perform inspections of approximately 40% of the structures using the inspection forms that are included in the GI/LID Plan for inclusion in the Annual Report due May 15, 2021.

4.6 Task 6: Highly Visible Pollutant Sources (HVPS) & Municipal Inspections

GMC staff will perform stormwater site inspection for approximately 20% of the City's HVPS sites based on the inventory and procedures included in the SWMP. Any issues discovered in the field will be reported to the City so that enforcement actions can be taken in accordance with the ERP, as needed. GMC will provide and summarize the results for inclusion in the Annual Report. In addition, GMC will perform stormwater site inspections for the City municipal facilities identified in the SWMP, including the Public Works and the Wastewater Treatment Plant.

4.7 Task 7: NPDES Annual Report 2020-2021 Preparation & Assistance
GMC will prepare the City's NPDES Phase I MS4 Annual Report covering the period of April 1, 2020 to March 31, 2021. In early 2021, GMC will provide City staff with a compliance matrix that will include a list of documentation that is needed for the Annual Report, after which, GMC staff will meet with City staff to review the documentation and identify any additional best management practices (BMPs) that need to be completed prior to March 31, 2021. Using the documentation compiled, GMC will prepare the Annual Report document, as well as documentation related to any other tasks completed by GMC staff, per this contract. GMC will provide the Annual Report to the City to review and revise it based on comments received from City staff. GMC will prepare and mail the submittal package for EPD, no later than May 15, 2021. GMC will provide the City with an electronic copy of the Annual Report. If requested, GMC will also provide a hard copy. Upon request, GMC can assist the City with addressing any comments from EPD on the Annual Report for an hourly, additional fee.

4.8 Task 8: Addressing EPD Comments on the NPDES Annual Report 2019-2020
The City should anticipate receiving comments from EPD on the 2019-2020 annual report that was submitted to EPD in May 2020. There were several activities that had not been completed by the City during the reporting period, and EPD is likely to note that in their review. If needed, GMC can assist the City with preparing a response to EPD comments. GMC would perform this work on an hourly basis, upon request from the City.

4.9 Project Schedule
The scope of services will be completed in compliance with the schedule provided by EPD. The updated SWMP and associated plans, including the ERP, IDDE Plan, and GI/LID Plan will be submitted to EPD on or before December 22, 2020. The field work described in this contract will be completed no later than March 31, 2021, and the 2020-2021 Annual Report and summaries of field work activities will be completed and submitted to EPD on or before May 15, 2021.

5.0 SECTION 5.0 – PROJECT BUDGET AND PAYMENTS TO CONSULTANT

CITY and CONSULTANT, in consideration of their mutual covenants herein, agree in respect of the performance of professional consulting services provided by CONSULTANT and the payment for those services by CITY as set forth below.

5.1 **Compensation.** The CITY shall compensate the CONSULTANT in accordance with the schedule of fees below. CONSULTANT shall invoice the CITY on a monthly, percent complete basis.

Tasks	Fee	Payment
Task 1: Update of Tybee Island NPDES Phase I Medium MS4 Stormwater Management Plan (SWMP) and Supporting Plans	\$12,900	Lump Sum, Additional Revisions are Hourly
Task 2: Dry Weather Screening/Illicit Discharge Monitoring	\$2,700	Additional Source Tracing @ \$95/hour
Task 3: Education, Training, and Community Outreach	\$2,580	Lump Sum
Task 4: MS4 Inventory Update & Inspection of the Stormwater Inventory	\$16,140	Lump Sum
Task 5: GI/LID Inventory & Inspections	\$2,280	Lump Sum
Task 6: Highly Visible Pollutant Sources (HVPS) & Municipal Inspections	\$3,360	Lump Sum
Task 7: NPDES Annual Report 2020-2021 Preparation & Assistance	\$8,520	Lump Sum
Task 8: Addressing EPD Comments on the NPDES Annual Report 2019-2020	up to \$2,500	Hourly, As Needed

5.2 **Payments.** For professional consulting services as outlined in this AGREEMENT, CITY shall pay CONSULTANT the stipulated fees. CONSULTANT shall submit monthly invoices to CITY in a format acceptable by the CITY. CITY shall endeavor to make payment to CONSULTANT within thirty (30) days from receipt of invoice.

5.3 **Hourly Services.** If the CITY requests that the CONSULTANT provide services on an hourly basis, or requests services not currently outlined in this AGREEMENT, the CONSULTANT will perform the services in accordance with the unit rates provided in the table below, or at a mutually agreeable fee arrangement. Prior to commencing any requested additional services, not included in the Scope of Services in Section 4.0, the CONSULTANT must notify the CITY promptly and provide an estimate of the budget to complete the requested services and a schedule. No additional services shall be performed by the CONSULTANT until written (i.e. letter) or electronic (i.e. email or fax) authorization is received by the CONSULTANT from the CITY.

Labor Category (Project Professional)	Hourly Rate
Vice President	\$ 205.00
Senior Professional (Engineer, Planner, Scientist, GIS, Project Manager)	\$ 195.00
Professional II (Engineer, Planner, Scientist, GIS, Project Manager)	\$ 175.00
Professional I (Engineer, Planner, Scientist, GIS, Project Manager)	\$ 155.00
Senior Consultant (Engineer, Planner, Scientist, GIS)	\$ 145.00
Consultant II (Engineer, Planner, Scientist, GIS)	\$ 135.00
Consultant I (Engineer, Planner, Scientist, GIS)	\$ 125.00
Senior Environmental Scientist/GIS Analyst	\$ 120.00
Environmental Scientist/GIS Analyst II	\$ 105.00
Environmental Scientist/GIS Analyst I	\$ 95.00

6.0 SECTION 6.0 - ACKNOWLEDGEMENT OF ACCEPTANCE

IN WITNESS WHEREOF, the parties hereto have made and executed this AGREEMENT as of the day and year first above written. This AGREEMENT constitutes the entire AGREEMENT between CITY and CONSULTANT.

CITY:

City of Tybee Island
403 Butler Avenue
Tybee Island, GA 31328

CONSULTANT:

Goodwyn Mills & Cawood
7 East Congress Street, Suite 504
Savannah, GA 31401

Signature: _____

Signature: _____

Name: _____

Name: Courtney Reich, Vice - President

Attest:

Attest:

Signature: _____

Signature: _____

Name: _____

Name: _____



City of Tybee Island

Memorandum

To: City of Tybee Island City Council Members
From: Pete Gulbranson, City Engineer/Director of Infrastructure
Date: October 30, 2020
Re: Professional Services Agreement with Goodwyn Mill and Cawood, Inc. (GMC)

Background

The City of Tybee is required to submit an annual report for the NPDES Phase I - MS4 Storm Water Management Plan to the Georgia Environmental Protection Division (EPD). The City has contracted with GMC in the preparation of the annual reports since 2017.

Overview

The EPD reviews the annual reports and comments on them. From the comments the City is required to make updates to the annual reports. EPD finally reviewed the annual reports for the years 2018-2019 and 2019-2020 and require updates to the annual report by December, 2020. The comments for the 2018-2019 annual report were completed earlier this year. As part of the EPD's comments they required the City to do additional dry weather screening and illicit discharge monitoring.

The NPDES 2020-2021 annual report is due on May 15, 2021. GMC, Inc. has prepared all of the City's annual reports and EOM has completed all the field work. Back in October of 2019 The City proposed to combine both the field work and report writing into one contract, instead of two separate contracts, and the City Council rejected the bids. Due to that action and the timing of the completion date we do not have a contract with either firm to prepare the annual report for 2020-2021, therefore we would like to extend the existing contract with GMC, Inc. to complete the 2020-2021 annual report.

Upon completion of the 2020-2021 annual report the City will once again procure the NPDES MS4 permit compliance services through another RFP process.

Summary

The City would like to establish a Professional Services Agreement with GMC, Inc. to update the 2019-2020 annual report based on the EPD's comments and then prepare the 2020-2021 annual report based on the costs of the attached agreement.

Recommended Next Steps:

Upon approval of the Professional Services contract, GMC, Inc. will update and perform all the necessary field work for both the 2019-2020 and 2020-2021 annual reports as required by the EPD. Upon completion GMC, Inc. will submit an updated 2019-2020 final 2020-2021 annual reports to keep the city in compliance.

File Attachments for Item:

7. Approval of award of contract subject to contract approval for south-end bathrooms with Johnson Laux Construction. The purpose of this project is to construction restrooms, changing rooms, and showers on the south end per the Strand Promenade Master Plan.

MAYOR
Shirley Sessions

CITY COUNCIL
Barry Brown, Mayor Pro tem
John Branigin
Nancy DeVetter
Jay Burke
Monty Parks
Spec Hosti

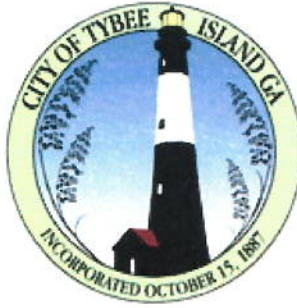

CITY MANAGER
Shawn Gillen

CITY CLERK
Janet LeViner

CITY ATTORNEY
Edward M. Hughes

CITY OF TYBEE ISLAND

BID 2020-754

PROJECT Public Restrooms

DUE 11-4-20 2:00pm

<u>BIDDER</u>	<u>BID</u>	<u>NOTES</u>
1. Johnson Laux	494,338-	
2. Copper Construction	639,553-	
3. RL Construction	524,389-	
4. DAVACO	1,846,970	
5. Basin Company	654,388.37	
6. Savannah Construction	639,999	
7. EB MORRIS	719,580-	
8. Belfor USA		No Bid Bond
9.		
10.		
11.		
12.		

OPENED BY:

Melissa Freeman

WITNESS:

Shawn Gillen



City of Tybee Island

Memorandum

To: City of Tybee Island City Council Members
From: Pete Gulbranson, City Engineer/Director of Infrastructure
Date: November 5, 2020
Re: Award of ITB 2020-754: Public Restrooms to Johnson Laux Construction, LLC

Background

The purpose of this project is to construction restrooms, changing rooms, and showers on the south end per the Strand Promenade Master Plan.

Overview

The City opened bids on Wednesday November 4, 2020 at 2:00 P.M. Eight (8) bids were received. The low bid was \$454,338.00 from Johnson-Laux Construction, LLC.

Summary

Funding for this project is through a SPLOST funding from the County.

Recommended Next Steps:

I would recommend award to the low bidder, Johnson-Laux Construction, LLC in the amount of \$454,338.00

**ATTACHMENT G
BID SHEET
ITB 2020-754
PUBLIC RESTROOMS**

Please attach all specifications regarding materials, installation, and warranties to this sheet with your total bid cost below.

Site Prep	11,800
Foundations	85,870
Restroom Walls	16,228
Roofing	34,400
Utilities within boundary of scope	34,920
Wood Framing/decks	217,200
Electrical/Mechanical	26,440
Plumbing Fixtures	29,480
TOTAL BID including contractor fees:	\$454,338.00

Johnson-Laux Construction, LLC(Firm)

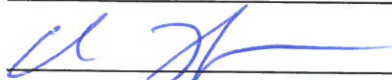
 (Signature)

GA Operations Manager (Title)

11/04/2020 (Date)

ATTACHMENT H

CHECKLIST FOR SUBMITTING BID

Sign below and submit this sheet with your bid

NOTE: All of the following items must be submitted with your bid to be considered "responsive". Remember to follow the Instructions in the ITB Documents.

- ACKNOWLEDGMENT OF ANY/ALL ADDENDUMS ✓
- W-9 ✓
- OCCUPATIONAL TAX CERTIFICATE ✓
- BID BOND ✓

COMPLETE AND SUBMIT ALL ATTACHMENTS TO THE BID:

- A. SIGNATURE SHEET ✓
- B. CONTRACTOR AFFIDAVIT ✓
- D. SAVE AFFIDAVIT ✓
- E. VENDOR INFORMATION ✓
- F. DEBARMENT CERTIFICATION ✓
- G. BID SHEET ✓
- H. CHECKLIST ✓

Chris Thompson, GA Operations Manager
NAME/TITLE

Johnson-Laux Construction, LLC
COMPANY NAME

7001 Chatham Center Drive, Suite 600
ADDRESS

Savannah, GA 31405
CITY/STATE/ZIP

912-480-0580
PHONE NUMBER

cthompson@johnson-laux.com
EMAIL

SIGNATURE

11/04/2020
DATE

AIA[®] Document A310[™] - 2010

Bid Bond

CONTRACTOR:

(Name, legal status and address)

Johnson - Laux Construction, LLC
650 Garden Commerce Parkway, Suite 100
Winter Garden, FL 34787

SURETY:

(Name, legal status and principal place of business)

North American Specialty Insurance Company
1200 Main Street, Ste 800
Kansas City, MO 64105

OWNER:

(Name, legal status and address)

City of Tybee Island
403 Butler Avenue
Tybee Island, GA 31328

BOND AMOUNT: * FIVE PERCENT OF AMOUNT BID *** (5%)**

PROJECT:

(Name, location or address, and Project number, if any)

ITB No. 2020-754; City of Tybee Island - Tybee Strand Promenade Restrooms

This document has important legal consequences. Consultation with an attorney is encouraged with respect to its completion or modification.

Any singular reference to Contractor, Surety, Owner or other party shall be considered plural where applicable.

The Contractor and Surety are bound to the Owner in the amount set forth above, for the payment of which the Contractor and Surety bind themselves, their heirs, executors, administrators, successors and assigns, jointly and severally, as provided herein. The conditions of this Bond are such that if the Owner accepts the bid of the Contractor within the time specified in the bid documents, or within such time period as may be agreed to by the Owner and Contractor, and the Contractor either (1) enters into a contract with the Owner in accordance with the terms of such bid, and gives such bond or bonds as may be specified in the bidding or Contract Documents, with a surety admitted in the jurisdiction of the Project and otherwise acceptable to the Owner, for the faithful performance of such Contract and for the prompt payment of labor and material furnished in the prosecution thereof; or (2) pays to the Owner the difference, not to exceed the amount of this Bond, between the amount specified in said bid and such larger amount for which the Owner may in good faith contract with another party to perform the work covered by said bid, then this obligation shall be null and void, otherwise to remain in full force and effect. The Surety hereby waives any notice of an agreement between the Owner and Contractor to extend the time in which the Owner may accept the bid. Waiver of notice by the Surety shall not apply to any extension exceeding sixty (60) days in the aggregate beyond the time for acceptance of bids specified in the bid documents, and the Owner and Contractor shall obtain the Surety's consent for an extension beyond sixty (60) days.

If this Bond is issued in connection with a subcontractor's bid to a Contractor, the term Contractor in this Bond shall be deemed to be Subcontractor and the term Owner shall be deemed to be Contractor.

When this Bond has been furnished to comply with a statutory or other legal requirement in the location of the Project, any provision in this Bond conflicting with said statutory or legal requirement shall be deemed deleted herefrom and provisions conforming to such statutory or other legal requirement shall be deemed incorporated herein. When so furnished, the intent is that this Bond shall be construed as a statutory bond and not as a common law bond.

Signed and sealed this 4th day of November, 2020

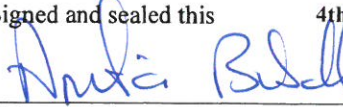
(Witness)

Johnson - Laux Construction, LLC

(Principal)

(Title) KEVIN JOHNSON - J.P.

North American Specialty Insurance Company

(Surety)

(Title) Bryce R. Guignard, Attorney-in-Fact & Licensed Non-Resident Agent State of Georgia

Guignard Company/Inquiries (407) 834-0022

CAUTION: You should sign an original AIA Contract Document, on which this text appears in RED. An original assures that changes will not be obscured.

Init.

AIA Document A310[™] - 2010. Copyright © 1963, 1970 and 2010 by The American Institute of Architects. All rights reserved. WARNING: This AIA[®] Document is protected by U.S. Copyright Law and International Treaties. Unauthorized reproduction or distribution of this AIA[®] Document, or any portion of it, may result in severe civil and criminal penalties, and will be prosecuted to the maximum extent possible under the law. Purchasers are permitted to reproduce ten (10) copies of this document when completed. To report copyright violations of AIA Contract Documents, e-mail The American Institute of Architects' legal counsel, copyright@aia.org.

Item #7.

- Page 48 -

SWISS RE CORPORATE SOLUTIONS

NORTH AMERICAN SPECIALTY INSURANCE COMPANY
WASHINGTON INTERNATIONAL INSURANCE COMPANY
WESTPORT INSURANCE CORPORATION GENERAL POWER OF ATTORNEY

KNOW ALL MEN BY THESE PRESENTS, THAT North American Specialty Insurance Company, a corporation duly organized and existing under laws of the State of New Hampshire, and having its principal office in the City of Kansas City, Missouri and Washington International Insurance Company a corporation organized and existing under the laws of the State of New Hampshire and having its principal office in the City of Kansas City, Missouri, and Westport Insurance Corporation, organized under the laws of the State of Missouri, and having its principal office in the City of Kansas City, Missouri does hereby make, constitute and appoint:

J.W. GUIGNARD, BRYCE R. GUIGNARD, PAUL J. CIAMBRIELLO, APRIL L. LIVELY, JENNIFER L. HINDLEY, MARGIE L. MORRIS, DEBORAH ANN MURRAY, M. GARY FRANCIS, CHRISTINE MORTON, KELLY PHELAN and ALLYSON FOSS WING JOINTLY OR SEVERALLY

Its true and lawful Attorney(s)-in-Fact, to make, execute, seal and deliver, for and on its behalf and as its act and deed, bonds or other writings obligatory in the nature of a bond on behalf of each of said Companies, as surety, on contracts of suretyship as are or may be required or permitted by law, regulation, contract or otherwise, provided that no bond or undertaking or contract or suretyship executed under this authority shall exceed the amount of: ONE HUNDRED TWENTY FIVE MILLION (\$125,000,000.00) DOLLARS

This Power of Attorney is granted and is signed by facsimile under and by the authority of the following Resolutions adopted by the Boards of Directors of North American Specialty Insurance Company and Washington International Insurance Company at meetings duly called and held on March 24, 2000 and Westport Insurance Corporation by written consent of its Executive Committee dated July 18, 2011.

RESOLVED, that any two of the President, any Senior Vice President, any Vice President, any Assistant Vice President, the Secretary or any Assistant Secretary be, and each or any of them hereby is authorized to execute a Power of Attorney qualifying the attorney named in the given Power of Attorney to execute on behalf of the Company bonds, undertakings and all contracts of surety, and that each or any of them hereby is authorized to attest to the execution of any such Power of Attorney and to attach therein the seal of the Company; and it is

FURTHER RESOLVED, that the signature of such officers and the seal of the Company may be affixed to any such Power of Attorney or to any certificate relating thereto by facsimile, and any such Power of Attorney or certificate bearing such facsimile signatures or facsimile seal shall be binding upon the Company when so affixed and in the future with regard to any bond, undertaking or contract of surety to which it is attached.

By Steven P. Anderson, Senior Vice President of Washington International Insurance Company & Senior Vice President of North American Specialty Insurance Company & Senior Vice President of Westport Insurance Corporation
By Mike A. Ito, Senior Vice President of Washington International Insurance Company & Senior Vice President of North American Specialty Insurance Company & Senior Vice President of Westport Insurance Corporation

IN WITNESS WHEREOF, North American Specialty Insurance Company, Washington International Insurance Company and Westport Insurance Corporation have caused their official seals to be hereunto affixed, and these presents to be signed by their authorized officers this 21st day of OCTOBER, 20 19.

North American Specialty Insurance Company
Washington International Insurance Company
Westport Insurance Corporation

State of Illinois
County of Cook
On this 21st day of OCTOBER, 20 19, before me, a Notary Public personally appeared Steven P. Anderson, Senior Vice President of Washington International Insurance Company and Senior Vice President of North American Specialty Insurance Company and Senior Vice President of Westport Insurance Corporation and Michael A. Ito Senior Vice President of Washington International Insurance Company and Senior Vice President of North American Specialty Insurance Company and Senior Vice President of Westport Insurance Corporation, personally known to me, who being by me duly sworn, acknowledged that they signed the above Power of Attorney as officers of and acknowledged said instrument to be the voluntary act and deed of their respective companies.

OFFICIAL SEAL M. KENNY Notary Public - State of Illinois My Commission Expires 12/04/2021
M. Kenny, Notary Public

I, Jeffrey Goldberg, the duly elected Vice President and Assistant Secretary of North American Specialty Insurance Company, Washington International Insurance Company and Westport Insurance Corporation do hereby certify that the above and foregoing is a true and correct copy of a Power of Attorney given by said North American Specialty Insurance Company, Washington International Insurance Company and Westport Insurance Corporation which is still in full force and effect.

IN WITNESS WHEREOF, I have set my hand and affixed the seals of the Companies this 4th day of November, 20 20.

Jeffrey Goldberg, Vice President & Assistant Secretary of Washington International Insurance Company & Vice President & Assistant Secretary of Westport Insurance Corporation

ATTACHMENT A

CITY OF TYBEE - INSTRUCTIONS TO BIDDER SIGNATURE SHEET

The Bidder certifies that he/she has examined all documents contained in this ITB package, and is familiar with all aspects of the ITB and understands fully all that is required of the successful Bidder. The Bidder further certifies that his/her Bid will not be withdrawn for sixty (60) days from the date on which his bid is submitted to the City.

The Bidder agrees, if awarded this Contract, he/she will:

A. Furnish, upon receipt of an authorized City of Tybee Island Purchase Order, all items indicated thereon as specified in this ITB for the bid amount; or,

B. Enter a contract with City of Tybee Island to do and/or furnish everything necessary to provide the service and/or accomplish the work as stated and/or specified in this ITB for the bid amount, and;

Johnson-Laux Construction, LLC

11/04/2020

COMPANY

DATE

SIGNATURE

GA Operations Manager

TITLE

912-480-0580

TELEPHONE NUMBER

MINORITY/FEMALE BUSINESS DEVELOPMENT PROGRAM: City of Tybee Island City Council established goals oriented to increase participation of minority and female owned businesses, through MBE/WBE certification and development. In order to accurately document participation, businesses submitting bids, quotes or proposals are encouraged to report ownership status. A minority or women business is defined as a business that is at least 51% owned and managed by minority or women.

A responder that is certified by any agency of the Federal Government or State of Georgia may submit a copy of their certification with their bid as proof of qualifications. Bidder that intends to engage in joint ventures or utilize sub-consultants must submit a report of Minority/Women Business Enterprise participation to Melissa Freeman, P.O. Box 2749, and City of Tybee Island, GA 31328.

African-American\Black ___ Asian American ___ Hispanic ___ Native American ___

Alaskan Indian ___ Female X

ATTACHMENT B

CONTRACTOR AFFIDAVIT under O.C.G.A. § 13-10-91(b) (1)

By executing this affidavit, the undersigned contractor verifies its compliance with O.C.G.A. § 13-10-91, stating affirmatively that the individual, firm or corporation which is engaged in the physical performance of services on behalf of CITY OF TYBEE ISLAND has registered with, is authorized to use and uses the federal work authorization program commonly known as E-Verify, or any subsequent replacement program, in accordance with the applicable provisions and deadlines established in O.C.G.A. § 13-10-91. Furthermore, the undersigned contractor will continue to use the federal work authorization program throughout the contract period and the undersigned contractor will contract for the physical performance of services in satisfaction of such contract only with subcontractors who present an affidavit to the contractor with the information required by O.C.G.A. § 13-10-91(b). Contractor hereby attests that its federal work authorization user identification number and date of authorization are as follows:

[REDACTED]
Federal Work Authorization User Identification Number

07/29/2011
Date of Authorization

Johnson-Laux Construction, LLC
Name of Contractor

Tybee Strand Promenade Restrooms
Name of Project

City of Tybee Island
Name of Public Employer

I hereby declare under penalty of perjury that the foregoing is true and correct.

Executed on Nov, 4, 2020 in Sav (city), Ga (state).

[Signature]
Signature of Authorized Officer or Agent

Chris Thompson, GA Operations Manager
Printed Name and Title of Authorized Officer or Agent

SUBSCRIBED AND SWORN BEFORE ME ON THIS THE 4th DAY OF Nov, 2020.

Rachel Noble
NOTARY PUBLIC
My Commission Expires: 03/23/2024

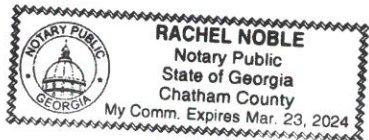

ATTACHMENT D

O.C.G.A. § 50-36-1(e)(2) Affidavit

By executing this affidavit under oath, as an applicant for a(n) Construction contract for a public benefit as referenced in O.C.G.A. § 50-36-1, from the CITY OF TYBEE ISLAND, Georgia, the undersigned applicant verifies one of the following with respect to my application for a public benefit:

- 1) *✓* I am a United States citizen.
- 2) _____ I am a legal permanent resident of the United States.
- 3) _____ I am a qualified alien or non-immigrant under the Federal Immigration and Nationality Act with an alien number issued by the Department of Homeland Security or other federal immigration agency.

My alien number issued by the Department of Homeland Security or other federal immigration agency is: _____.

The undersigned applicant also hereby verifies that he or she is 18 years of age or older and has provided at least one secure and verifiable document, as required by O.C.G.A. § 50-36-1(e)(1), with this affidavit.

The secure and verifiable document provided with this affidavit can best be classified as: Drivers License

In making the above representation under oath, I understand that any person who knowingly and willfully makes a false, fictitious, or fraudulent statement or representation in an affidavit will be guilty of a violation of O.C.G.A. § 16-10-20, and face criminal penalties as allowed by such criminal statute.

Executed in Savannah (city), Georgia (state).

Chris Thompson
Signature of Applicant

Chris Thompson
Printed Name of Applicant

SUBSCRIBED AND SWORN BEFORE ME ON THE 4th DAY OF November, 2020

Rachel Noble
NOTARY PUBLIC
My Commission Expires: 03/23/2024

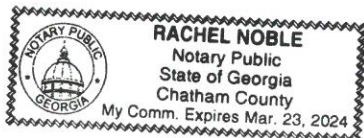

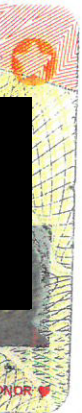
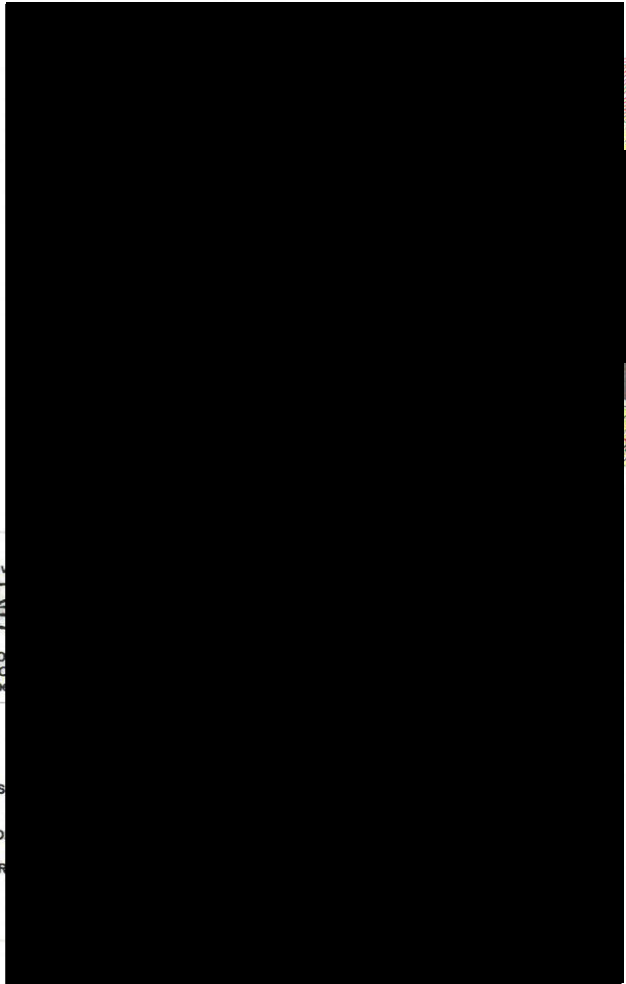

Rev
MED
INFC
Non

CLAS
ENDO
RESTR

ATTACHMENT F
CERTIFICATION REGARDING DEBARMENT

INSTRUCTIONS FOR CERTIFICATION REGARDING DEBARMENT, SUSPENSION,
INELIGIBILITY AND VOLUNTARY EXCLUSION:

By signing and submitting this bid, the prospective lower tier participant is providing the signed certification set out below.

1. The certification referred to in this paragraph is a material representation of fact upon which reliance was placed when this transaction was entered into. If it is later determined that the prospective lower tier participant knowingly rendered an erroneous certification, in addition to other remedies available to the Federal Government, the City of Tybee Island may pursue available remedies, including suspension and/or debarment.
2. The prospective lower tier participant shall provide immediate written notice to the City if at any time the prospective lower tier participant learns that its certification was erroneous when submitted or has become erroneous by reason of changed circumstances.
3. The terms “covered transaction,” “debarred,” “suspended,” “ineligible,” “lower tier covered participant,” “persons,” “lower tier covered transaction,” “principal,” “bid,” and “voluntarily excluded,” as used in this paragraph, have the meanings set out in the Definitions and Coverage sections of rules implementing Executive Order 12549, 49 CFR part 29.
4. The prospective lower tier participant agrees by submitting this bid that, should the proposed covered transaction be entered into, it shall not knowingly enter into any lower tier covered transaction with a person who is debarred, suspended, declared ineligible, or voluntarily excluded from participation in this covered transaction, unless authorized in writing by the City.
5. The prospective lower tier participant further agrees by submitting this bid that it will include the clause titled “Certification Regarding Debarment, Suspension, Ineligibility and Voluntary Exclusion — Lower Tier Covered Transaction,” without modification, in all lower tier covered transactions and in all solicitations for lower tier covered transactions.
6. A participant in a covered transaction may rely upon certification of a prospective participant in a lower tier covered transaction that it is not debarred, suspended, ineligible, or voluntarily excluded from the covered transaction, unless it knows that the certification is erroneous. A participant may decide the method and frequency by which it determines the eligibility of its principles. Each participant may, but is not required to, check the Nonprocurement List issued by U.S. General Service Administration.
7. Nothing contained in the foregoing shall be construed to require establishment of a system of records in order to render in good faith the certification required by this paragraph. The knowledge and information of a participant is not required to exceed that which is normally possessed by a prudent person in the ordinary course of business dealings.

8. Except for transactions authorized under paragraph 4 of these instructions, if a participant in a covered transaction knowingly enters into a lower tier covered transaction with a person who is suspended, debarred, ineligible, or voluntarily excluded from participation in this transaction, in addition to other remedies available to the Federal Government, the City may pursue available remedies, including suspension and/or debarment.

NAME OF COMPANY: Johnson-Laux Construction, LLC

COMPANY TAX ID: [REDACTED]

NAME OF AUTHORIZED REPRESENTATIVE: Chris Thompson

TITLE OF AUTHORIZED REPRESENTATIVE: Georgia Operations Manager

SIGNATURE:  DATE: 11/03/2020

**CITY OF TYBEE ISLAND
ITB NO. 2020-754 PUBLIC RESTROOMS
ADDENDUM #1**

BID DUE: WEDNESDAY, NOVEMBER 4, 2020 by 2:00pm

The following information should be considered in preparation of responses to the above named Invitation to Bid, and is hereby incorporated into the original ITB document.

All other terms, conditions, specifications, and requirements as noted in the original RFP remain unchanged and must be met. Return this signed addendum with your proposal response.

Name of Company: Johnson-Laux Construction, LLC

Name/Title: Chris Thompson, Georgia Operations Manager

Signature:  _____

**CITY OF TYBEE ISLAND
ITB NO. 2020-754 PUBLIC RESTROOMS
ADDENDUM #2**

BID DUE: WEDNESDAY, NOVEMBER 4, 2020 by 2:00pm

The following information should be considered in preparation of responses to the above named Invitation to Bid, and is hereby incorporated into the original ITB document.

All other terms, conditions, specifications, and requirements as noted in the original RFP remain unchanged and must be met. Return this signed addendum with your proposal response.

Name of Company: Johnson-Laux Construction, LLC

Name/Title: Chris Thompson, GA Operations Manager

Signature:  _____

ATTACHMENT E

CITY OF TYBEE ISLAND VENDOR INFORMATION

Vendor Name: Johnson-Laux Construction, LLC

Product or Services Provided: General Contractor - Construction

Sales Contact Information

Contact: Chris Thompson Email: cthompson@johnson-laux.com

Phone: 912-480-0580 Fax: 912-480-0581

Address:
7001 Chatham Center Drive, Suite 600, Savannah, GA 31405

Accounts Receivable Information

Contact: Mari Norman Email: ap@johnson-laux.com

Phone: 407-770-2180 Fax: 407-770-2181

Remittance Address: 3066 Mercer University Drive, Unit 200, Winter Garden, FL 34787

Federal Tax Id #: 59-3674291

Attach Copy of W-9 and Occupational Tax Certificate

Provide Copy of Worker's Comp Coverage when providing any service involving labor on City property.
Our terms are net 30

Request for Taxpayer Identification Number and Certification

**Give Form to the
requester. Do not
send to the IRS.**

▶ Go to www.irs.gov/FormW9 for instructions and the latest information.

1 Name (as shown on your income tax return). Name is required on this line; do not leave this line blank. Johnson-Laux Construction, LLC	
2 Business name/disregarded entity name, if different from above	
3 Check appropriate box for federal tax classification of the person whose name is entered on line 1. Check only one of the following seven boxes. <input type="checkbox"/> Individual/sole proprietor or single-member LLC <input type="checkbox"/> C Corporation <input type="checkbox"/> S Corporation <input type="checkbox"/> Partnership <input type="checkbox"/> Trust/estate <input checked="" type="checkbox"/> Limited liability company. Enter the tax classification (C=C corporation, S=S corporation, P=Partnership) ▶ S Note: Check the appropriate box in the line above for the tax classification of the single-member owner. Do not check LLC if the LLC is classified as a single-member LLC that is disregarded from the owner unless the owner of the LLC is another LLC that is not disregarded from the owner for U.S. federal tax purposes. Otherwise, a single-member LLC that is disregarded from the owner should check the appropriate box for the tax classification of its owner. <input type="checkbox"/> Other (see instructions) ▶	4 Exemptions (codes apply only to certain entities, not individuals; see instructions on page 3): Exempt payee code (if any) _____ Exemption from FATCA reporting code (if any) _____ <small>(Applies to accounts maintained outside the U.S.)</small>
5 Address (number, street, and apt. or suite no.) See instructions. 650 Garden Commerce Parkway, Suite 100	Requester's name and address (optional)
6 City, state, and ZIP code Winter Garden, FL 34787	
7 List account number(s) here (optional)	

Part I Taxpayer Identification Number (TIN)

Enter your TIN in the appropriate box. The TIN provided must match the name given on line 1 to avoid backup withholding. For individuals, this is generally your social security number (SSN). However, for a resident alien, sole proprietor, or disregarded entity, see the instructions for Part I, later. For other entities, it is your employer identification number (EIN). If you do not have a number, see *How to get a TIN*, later.

Social security number									

Note: If the account is in more than one name, see the instructions for line 1. Also see *What Name and Number To Give the Requester* for guidelines on whose number to enter.

Part II Certification

Under penalties of perjury, I certify that:

1. The number shown on this form is my correct taxpayer identification number (or I am waiting for a number to be issued to me); and
2. I am not subject to backup withholding because: (a) I am exempt from backup withholding, or (b) I have not been notified by the Internal Revenue Service (IRS) that I am subject to backup withholding as a result of a failure to report all interest or dividends, or (c) the IRS has notified me that I am no longer subject to backup withholding; and
3. I am a U.S. citizen or other U.S. person (defined below); and
4. The FATCA code(s) entered on this form (if any) indicating that I am exempt from FATCA reporting is correct.

Certification instructions. You must cross out item 2 above if you have been notified by the IRS that you are currently subject to backup withholding because you have failed to report all interest and dividends on your tax return. For real estate transactions, item 2 does not apply. For mortgage interest paid, acquisition or abandonment of secured property, cancellation of debt, contributions to an individual retirement arrangement (IRA), and generally, payments other than interest and dividends, you are not required to sign the certification, but you must provide your correct TIN. See the instructions for Part II, later.

Sign Here	Signature of U.S. person ▶	Date ▶ 1/24/2020
------------------	----------------------------	-------------------------

General Instructions

Section references are to the Internal Revenue Code unless otherwise noted.

Future developments. For the latest information about developments related to Form W-9 and its instructions, such as legislation enacted after they were published, go to www.irs.gov/FormW9.

Purpose of Form

An individual or entity (Form W-9 requester) who is required to file an information return with the IRS must obtain your correct taxpayer identification number (TIN) which may be your social security number (SSN), individual taxpayer identification number (ITIN), adoption taxpayer identification number (ATIN), or employer identification number (EIN), to report on an information return the amount paid to you, or other amount reportable on an information return. Examples of information returns include, but are not limited to, the following.

- Form 1099-INT (interest earned or paid)

- Form 1099-DIV (dividends, including those from stocks or mutual funds)
- Form 1099-MISC (various types of income, prizes, awards, or gross proceeds)
- Form 1099-B (stock or mutual fund sales and certain other transactions by brokers)
- Form 1099-S (proceeds from real estate transactions)
- Form 1099-K (merchant card and third party network transactions)
- Form 1098 (home mortgage interest), 1098-E (student loan interest), 1098-T (tuition)
- Form 1099-C (canceled debt)
- Form 1099-A (acquisition or abandonment of secured property)

Use Form W-9 only if you are a U.S. person (including a resident alien), to provide your correct TIN.

If you do not return Form W-9 to the requester with a TIN, you might be subject to backup withholding. See What is backup withholding, later.

SAVANNAH

Revenue Department

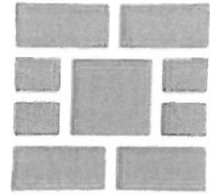

305 Fahm St | PO Box 1228 | Savannah, GA 31402-1228 | (912)651-6445

2020 BUSINESS TAX CERTIFICATE

Expires: December 31, 2020

JOHNSON LAUX CONSTRUCTION, LLC
7001 CHATHAM CENTER DR STE 600
SAVANNAH GA 31405

Business Owner(s): KEVIN JOHNSON

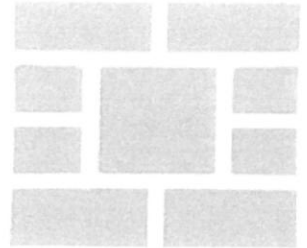
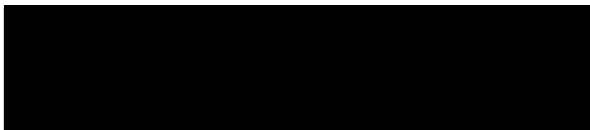

Classification: Administrative Mgmt and Gen Management Cons Svcs

THIS CERTIFICATE MUST BE DISPLAYED PROMINENTLY IN THE BUSINESS

PM ID: 273823
fj 3/9/2020 10:59:54AM

REVENUE DEPARTMENT
305 FAHM ST
PO BOX 1228
SAVANNAH, GA 31402-1228
(912) 651-6445

Above is your 2020 City of Savannah Business Tax Certificate. Please post it in a prominent place at your business. A pocket-sized license card is below. Please be sure to keep this card on you at all times. If any information appearing on the certificate is incorrect, please contact the Revenue Department at the address or phone number above.

SAVANNAH
Revenue Department



2020 BUSINESS TAX CERTIFICATE

Administrative Mgmt and Gen Management Cons Svcs Additional Info:
JOHNSON LAUX CONSTRUCTION, LLC
7001 CHATHAM CENTER DR STE 600
SAVANNAH GA 31405
KEVIN JOHNSON, Owner

JOHNSON LAUX CONSTRUCTION, LLC
7001 CHATHAM CENTER DR STE 600
SAVANNAH GA 31405

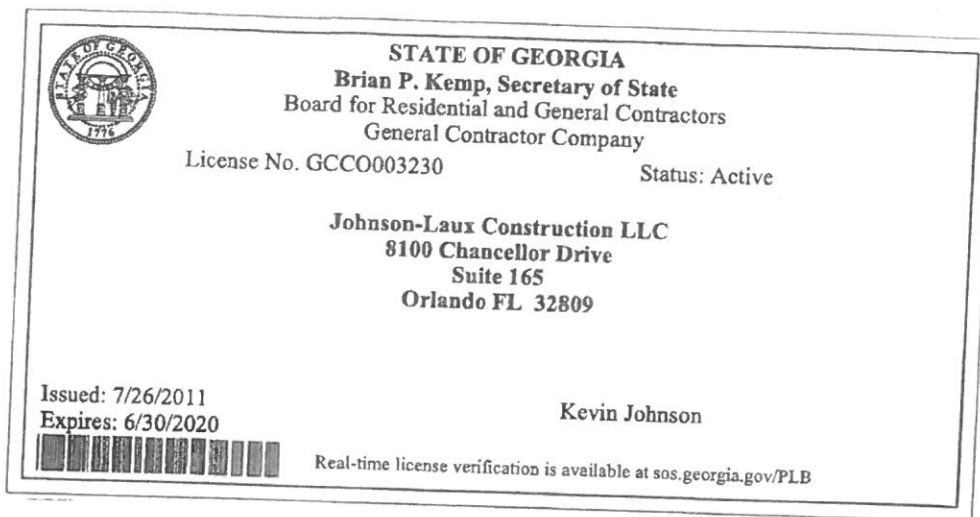

Above is your license issued by the Georgia State Board of Residential and General Contractors. A pocket-sized license card is below. Please make note of the expiration date on your license. It is your responsibility to renew your license before it expires. License renewals may be completed prior to the expiration date via the Board's website or by obtaining a paper renewal from the Board office.

Reminder: It is your responsibility to keep your insurance current. Please provide the Board with a copy of your Certificate of Insurance each time your insurance is renewed. The Board does receive copies of cancellation notices which will affect the status of your license.

It is the licensee's responsibility to notify the board office immediately of any change of name or address. You may update your address online at the board's website at www.sos.ga.gov/plb/contractors/.

You may contact the Board at:
GEORGIA STATE BOARD FOR RESIDENTIAL & GENERAL CONTRACTORS
237 COLISEUM DRIVE, MACON, GEORGIA 31217-3858
478-207-2440 (phone) website: www.sos.ga.gov/plb/contractors/

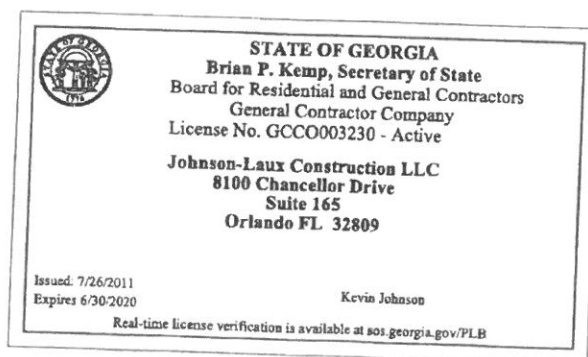

STATE OF GEORGIA

Secretary of State

Corporations Division

313 West Tower

2 Martin Luther King, Jr. Dr.

Atlanta, Georgia 30334-1530

Annual Registration

Electronically Filed

Secretary of State

Filing Date: 01/13/2020 06:22:50

BUSINESS INFORMATION

BUSINESS NAME : JOHNSON-LAUX CONSTRUCTION, LLC
CONTROL NUMBER : [REDACTED]
BUSINESS TYPE : Foreign Limited Liability Company
JURISDICTION : Florida
ANNUAL REGISTRATION PERIOD : 2020, 2021, 2022

BUSINESS INFORMATION CURRENTLY ON FILE

PRINCIPAL OFFICE ADDRESS : 7001 Chatham Center Dr., Suite 600, Savannah, GA, 31405, USA
REGISTERED AGENT NAME : CAPITOL CORPORATE SERVICES, INC.
REGISTERED OFFICE ADDRESS : 3675 CRESTWOOD PARKWAY,SUITE 350, DULUTH, GA, 30096, USA
REGISTERED OFFICE COUNTY : Gwinnett

UPDATES TO ABOVE BUSINESS INFORMATION

PRINCIPAL OFFICE ADDRESS : 7001 Chatham Center Dr., Suite 600, Savannah, GA, 31405, USA
REGISTERED AGENT NAME : CAPITOL CORPORATE SERVICES, INC.
REGISTERED OFFICE ADDRESS : 3675 CRESTWOOD PARKWAY,SUITE 350, DULUTH, GA, 30096, USA
REGISTERED OFFICE COUNTY : Gwinnett

AUTHORIZER INFORMATION

AUTHORIZER SIGNATURE : Sallie Holland
AUTHORIZER TITLE : Authorized Person



Brown & Brown of Florida, Inc.
2290 Lucien Way, Suite 400
Maitland, Florida 32751-7234
o: 407.660.8282 f: 407.660.2012
www.bborlando.com

ORLANDO

November 4, 2020

City of Tybee Island, GA
403 Butler Ave
Tybee Island, GA 31328

Johnson-Laux Construction, LLC
650 Garden Commerce Way
Suite 100
Winter Garden, FL 34787

RE: Project: Tybee Strand Promenade Restrooms ITB #2020-754

To Whom It May Concern:

It has been the privilege of Brown & Brown of Florida Inc. to provide liability, and builders risk insurance for Johnson-Laux Construction LLC since 2011. They have an excellent reputation in the community and we value them as a client.

Should the above referenced project be awarded to Johnson-Laux Construction LLC, we welcome the opportunity to provide any coverages required but not indicated in the Certificate of Insurance provided for this bid.

Brown & Brown, its brokers and carriers reserve the right to perform normal underwriting at the time of any insurance request, including, without limitation, prior review and approval of relevant contract documents and applications. Brown & Brown assumes no liability to City of Tybee Island, GA, or its affiliates, if for any reason we do not bind such policies.

If any additional information is needed, please do not hesitate to contact me.

Sincerely,

A handwritten signature in cursive script that reads "Nicole Long".

Nicole Long, Senior Vice President – Sales Leader
407-660-8282 x 2305
Nlong@BBOrlando.com



CERTIFICATE OF LIABILITY INSURANCE

DATE (MM/DD/YYYY)

11/04/2020

THIS CERTIFICATE IS ISSUED AS A MATTER OF INFORMATION ONLY AND CONFERS NO RIGHTS UPON THE CERTIFICATE HOLDER. THIS CERTIFICATE DOES NOT AFFIRMATIVELY OR NEGATIVELY AMEND, EXTEND OR ALTER THE COVERAGE AFFORDED BY THE POLICIES BELOW. THIS CERTIFICATE OF INSURANCE DOES NOT CONSTITUTE A CONTRACT BETWEEN THE ISSUING INSURER(S), AUTHORIZED REPRESENTATIVE OR PRODUCER, AND THE CERTIFICATE HOLDER.

IMPORTANT: If the certificate holder is an ADDITIONAL INSURED, the policy(ies) must have ADDITIONAL INSURED provisions or be endorsed. If SUBROGATION IS WAIVED, subject to the terms and conditions of the policy, certain policies may require an endorsement. A statement on this certificate does not confer rights to the certificate holder in lieu of such endorsement(s).

PRODUCER Brown & Brown of Florida, Inc. 2290 Lucien Way, Suite 400 Maitland FL 32751		CONTACT NAME: Brandy Robbins PHONE (A/C, No, Ext): (407) 660-8282 E-MAIL ADDRESS: BRobbins@bborlando.com FAX (A/C, No): (386) 239-5729	
		INSURER(S) AFFORDING COVERAGE	
		INSURER A: National Trust Insurance Co.	NAIC # 20141
		INSURER B: FCCI Insurance Company	10178
		INSURER C: Monroe Guaranty Insurance Company	32506
		INSURER D:	
		INSURER E:	
		INSURER F:	

COVERAGES**CERTIFICATE NUMBER:** CL19122622067**REVISION NUMBER:**

THIS IS TO CERTIFY THAT THE POLICIES OF INSURANCE LISTED BELOW HAVE BEEN ISSUED TO THE INSURED NAMED ABOVE FOR THE POLICY PERIOD INDICATED. NOTWITHSTANDING ANY REQUIREMENT, TERM OR CONDITION OF ANY CONTRACT OR OTHER DOCUMENT WITH RESPECT TO WHICH THIS CERTIFICATE MAY BE ISSUED OR MAY PERTAIN, THE INSURANCE AFFORDED BY THE POLICIES DESCRIBED HEREIN IS SUBJECT TO ALL THE TERMS, EXCLUSIONS AND CONDITIONS OF SUCH POLICIES. LIMITS SHOWN MAY HAVE BEEN REDUCED BY PAID CLAIMS.

INSR LTR	TYPE OF INSURANCE	ADDL INSD	SUBR WVD	POLICY NUMBER	POLICY EFF (MM/DD/YYYY)	POLICY EXP (MM/DD/YYYY)	LIMITS	
A	<input checked="" type="checkbox"/> COMMERCIAL GENERAL LIABILITY	Y		GL100035615	01/01/2020	01/01/2021	EACH OCCURRENCE	\$ 1,000,000
	<input type="checkbox"/> CLAIMS-MADE <input checked="" type="checkbox"/> OCCUR						DAMAGE TO RENTED PREMISES (Ea occurrence)	\$ 100,000
	Deductible PD, per claim: \$2,000						MED EXP (Any one person)	\$ 5,000
	<input checked="" type="checkbox"/> Contractual per GL Form						PERSONAL & ADV INJURY	\$ 1,000,000
GEN'L AGGREGATE LIMIT APPLIES PER:							GENERAL AGGREGATE	\$ 2,000,000
<input type="checkbox"/> POLICY <input checked="" type="checkbox"/> PRO-JECT <input checked="" type="checkbox"/> LOC							PRODUCTS - COMP/OP AGG	\$ 2,000,000
OTHER:								\$
C	AUTOMOBILE LIABILITY	Y		CA100021013	01/01/2020	01/01/2021	COMBINED SINGLE LIMIT (Ea accident)	\$ 1,000,000
	<input checked="" type="checkbox"/> ANY AUTO						BODILY INJURY (Per person)	\$
	<input type="checkbox"/> OWNED AUTOS ONLY <input type="checkbox"/> SCHEDULED AUTOS						BODILY INJURY (Per accident)	\$
	<input checked="" type="checkbox"/> HIRED AUTOS ONLY <input checked="" type="checkbox"/> NON-OWNED AUTOS ONLY						PROPERTY DAMAGE (Per accident)	\$
								\$
B	<input checked="" type="checkbox"/> UMBRELLA LIAB			UMB100053976	01/01/2020	01/01/2021	EACH OCCURRENCE	\$ 10,000,000
	<input type="checkbox"/> EXCESS LIAB						AGGREGATE	\$ 10,000,000
	DED <input checked="" type="checkbox"/> RETENTION \$ 10,000							\$
B	WORKERS COMPENSATION AND EMPLOYERS' LIABILITY	N/A		001-WC20A-76925	01/01/2020	01/01/2021	<input checked="" type="checkbox"/> PER STATUTE	OTH-ER
	ANY PROPRIETOR/PARTNER/EXECUTIVE OFFICER/MEMBER EXCLUDED? (Mandatory in NH)							
	E.L. EACH ACCIDENT						\$ 1,000,000	
	E.L. DISEASE - EA EMPLOYEE						\$ 1,000,000	
If yes, describe under DESCRIPTION OF OPERATIONS below							E.L. DISEASE - POLICY LIMIT	\$ 1,000,000
B	Inland Marine - Contractor's Equipment			CM100035614	01/01/2020	01/01/2021	Rented/Leased Equip.	\$ 250,000

DESCRIPTION OF OPERATIONS / LOCATIONS / VEHICLES (ACORD 101, Additional Remarks Schedule, may be attached if more space is required)

RE: Project: Tybee Strand Promenade Restrooms, ITB #2020-754

City of Tybee Island, GA is granted additional insured status by the General Liability policy with regard to the ongoing and completed operations of the named insured when required by written contract or agreement.

City of Tybee Island, GA is granted additional insured status by the Automobile Liability policy with regard to the operations of the named insured when required by written contract or agreement.

Umbrella follows form of the underlying policies.

CERTIFICATE HOLDER**CANCELLATION**

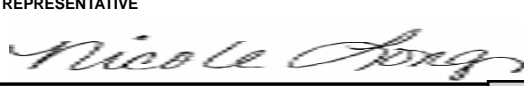
City of Tybee Island, GA 403 Butler Ave Tybee Island GA 31328	SHOULD ANY OF THE ABOVE DESCRIBED POLICIES BE CANCELLED BEFORE THE EXPIRATION DATE THEREOF, NOTICE WILL BE DELIVERED IN ACCORDANCE WITH THE POLICY PROVISIONS. AUTHORIZED REPRESENTATIVE 
---	---

Item #7.

016/03)

© 1988-2015 ACORD CORPORATION. All

The ACORD name and logo are registered marks of ACORD

- Page 64 -

THIS ENDORSEMENT CHANGES THE POLICY. PLEASE READ IT CAREFULLY.

**ADDITIONAL INSURED – OWNERS, LESSEES OR CONTRACTORS –
AUTOMATIC STATUS WHEN REQUIRED IN CONSTRUCTION
AGREEMENT WITH YOU – ONGOING OPERATIONS AND
PRODUCTS-COMPLETED OPERATIONS**

This endorsement modifies insurance provided under the following:

COMMERCIAL GENERAL LIABILITY COVERAGE FORM

SCHEDULE (OPTIONAL)

Name of Additional Insured Persons or Organizations

(As required by written contract or agreement per Paragraph A. below.)

Empty box for listing names of additional insured persons or organizations.

Locations of Covered Operations

(As per the written contract or agreement, provided the location is within the "coverage territory".)
BLANKET LOCATIONS

Empty box for listing locations of covered operations.

(Information required to complete this Schedule, if not shown above, will be shown in the Declarations.)

A. **Section II – Who Is An Insured** is amended to include as an additional insured:

1. Any person or organization for whom you are performing operations when you and such person or organization have agreed in writing in a contract or agreement in effect during the term of this policy that such person or organization be added as an additional insured on your policy; and
2. Any other person or organization you are required to add as an additional insured under the contract or agreement described in Paragraph 1. above; and

3. The particular person or organization, if any, scheduled above.

Such person(s) or organization(s) is an additional insured only with respect to liability for "bodily injury", "property damage" or "personal and advertising injury" occurring after the execution of the contract or agreement described in Paragraph 1. above and caused, in whole or in part, by:

1. Your acts or omissions; or
2. The acts or omissions of those acting on your behalf in the performance of your ongoing operations for the additional insured; or
3. "Your work" performed for the additional insured and included in the "products-completed operations hazard" if such coverage is specifically required in the written contract or agreement.

However, the insurance afforded to such additional insured(s) described above:

1. Only applies to the extent permitted by law;
2. Will not be broader than that which you are required by the contract or agreement to provide for such additional insured;
3. Will not be broader than that which is afforded to you under this policy; and
4. Nothing herein shall extend the term of this policy.

B. The insurance provided to the additional insured does not apply to "bodily injury", "property damage" or "personal and advertising injury" arising out of the rendering of, or the failure to render, any professional architectural, engineering or surveying services, including:

1. The preparing, approving, or failing to prepare or approve, maps, shop drawings, opinions, reports, surveys, field orders, change orders or drawings and specifications; or
2. Supervisory, inspection, architectural or engineering activities.

C. This insurance is excess over any other valid and collectible insurance available to the additional insured whether on a primary, excess, contingent or any other basis; unless the written contract or agreement requires that this insurance be primary and non-contributory, in which case this insurance will be primary and non-contributory relative to insurance on which the additional insured is a Named Insured.

D. With respect to the insurance afforded to these additional insureds, the following is added to **Section III – Limits of Insurance**:

The most we will pay on behalf of the additional insured is the amount of insurance:

1. Required by the contract or agreement described in Paragraph A.1.; or
2. Available under the applicable Limits of Insurance shown in the Declarations;

whichever is less.

This endorsement shall not increase the applicable Limits of Insurance shown in the Declarations.

E. **Section IV – Commercial General Liability Conditions** is amended as follows:

The Duties In The Event of Occurrence, Offense, Claim or Suit condition is amended to add the following additional conditions applicable to the additional insured:

An additional insured under this endorsement must as soon as practicable:

1. Give us written notice of an "occurrence" or an offense which may result in a claim or "suit" under this insurance, and of any claim or "suit" that does result;
2. Send us copies of all legal papers received in connection with the claim or "suit", cooperate with us in the investigation or settlement of the claim or defense against the "suit", and otherwise comply with all policy conditions; and
3. Tender the defense and indemnity of any claim or "suit" to any provider of other insurance which would cover the additional insured for a loss we cover under this endorsement and agree to make available all such other insurance. However, this condition does not affect Paragraph C. above.

We have no duty to defend or indemnify an additional insured under this endorsement until we receive from the additional insured written notice of a claim or "suit".

- F. This endorsement does not apply to any additional insured or project that is specifically identified in any other additional insured endorsement attached to the Commercial General Liability Coverage Form.

THIS ENDORSEMENT CHANGES THE POLICY. PLEASE READ IT CAREFULLY.

**ADDITIONAL INSURED – OWNERS, LESSEES OR CONTRACTORS –
AUTOMATIC STATUS WHEN REQUIRED IN CONSTRUCTION
AGREEMENT WITH YOU – ONGOING OPERATIONS AND
PRODUCTS-COMPLETED OPERATIONS**

This endorsement modifies insurance provided under the following:

COMMERCIAL GENERAL LIABILITY COVERAGE FORM

SCHEDULE (OPTIONAL)

Name of Additional Insured Persons or Organizations

(As required by written contract or agreement per Paragraph A. below.)

[Empty box for Name of Additional Insured Persons or Organizations]

Locations of Covered Operations

(As per the written contract or agreement, provided the location is within the "coverage territory".)
BLANKET LOCATIONS

[Empty box for Locations of Covered Operations]

(Information required to complete this Schedule, if not shown above, will be shown in the Declarations.)

A. **Section II – Who Is An Insured** is amended to include as an additional insured:

1. Any person or organization for whom you are performing operations when you and such person or organization have agreed in writing in a contract or agreement in effect during the term of this policy that such person or organization be added as an additional insured on your policy; and
2. Any other person or organization you are required to add as an additional insured under the contract or agreement described in Paragraph 1. above; and

3. The particular person or organization, if any, scheduled above.

Such person(s) or organization(s) is an additional insured only with respect to liability for "bodily injury", "property damage" or "personal and advertising injury" occurring after the execution of the contract or agreement described in Paragraph 1. above and caused, in whole or in part, by:

1. Your acts or omissions; or
2. The acts or omissions of those acting on your behalf in the performance of your ongoing operations for the additional insured; or
3. "Your work" performed for the additional insured and included in the "products-completed operations hazard" if such coverage is specifically required in the written contract or agreement.

However, the insurance afforded to such additional insured(s) described above:

1. Only applies to the extent permitted by law;
2. Will not be broader than that which you are required by the contract or agreement to provide for such additional insured;
3. Will not be broader than that which is afforded to you under this policy; and
4. Nothing herein shall extend the term of this policy.

B. The insurance provided to the additional insured does not apply to "bodily injury", "property damage" or "personal and advertising injury" arising out of the rendering of, or the failure to render, any professional architectural, engineering or surveying services, including:

1. The preparing, approving, or failing to prepare or approve, maps, shop drawings, opinions, reports, surveys, field orders, change orders or drawings and specifications; or
2. Supervisory, inspection, architectural or engineering activities.

C. This insurance is excess over any other valid and collectible insurance available to the additional insured whether on a primary, excess, contingent or any other basis; unless the written contract or agreement requires that this insurance be primary and non-contributory, in which case this insurance will be primary and non-contributory relative to insurance on which the additional insured is a Named Insured.

D. With respect to the insurance afforded to these additional insureds, the following is added to **Section III – Limits of Insurance**:

The most we will pay on behalf of the additional insured is the amount of insurance:

1. Required by the contract or agreement described in Paragraph A.1.; or
2. Available under the applicable Limits of Insurance shown in the Declarations;

whichever is less.

This endorsement shall not increase the applicable Limits of Insurance shown in the Declarations.

E. **Section IV – Commercial General Liability Conditions** is amended as follows:

The Duties In The Event of Occurrence, Offense, Claim or Suit condition is amended to add the following additional conditions applicable to the additional insured:

An additional insured under this endorsement must as soon as practicable:

FIRST CHOICE CONTRACTORS LIABILITY ENDORSEMENT

TABLE OF CONTENTS

DESCRIPTION	PAGE
Additional Insured Coverage	9
Bail Bonds.....	9
Blanket Waiver of Subrogation.....	14
Bodily Injury and Property Damage	1
Care, Custody or Control.....	3
Contractors Errors and Omissions	6
Contractual Liability (Personal & Advertising Injury)	2
Electronic Data Liability	1
General Liability Conditions.....	13
Incidental Malpractice.....	9
Insured.....	9
Limited Product Withdrawal Expense	3
Limits of Insurance	11
Loss of Earnings.....	9
Lost Key Coverage	8
Newly Formed or Acquired Organizations	11
Non-Owned Watercraft.....	1
Property Damage Liability – Borrowed Equipment	1
Tenant’s Property and Premises Rented To You	8
Voluntary Property Damage	2

THIS ENDORSEMENT CHANGES THE POLICY. PLEASE READ IT CAREFULLY.

FIRST CHOICE CONTRACTORS LIABILITY ENDORSEMENT

This endorsement modifies insurance provided under the following:

COMMERCIAL GENERAL LIABILITY COVERAGE FORM

NOTE: The following are additions, replacements and amendments to the Commercial General Liability Coverage Form, and will apply unless excluded by separate endorsement(s) to the Commercial General Liability Coverage Form.

The **COMMERCIAL GENERAL LIABILITY COVERAGE FORM** is amended as follows:

SECTION I - COVERAGES, COVERAGE A. BODILY INJURY AND PROPERTY DAMAGE is amended as follows:

1. Extended "Property Damage"

Exclusion 2.a., Expected or Intended Injury, is replaced with the following:

- a. "Bodily injury" or "property damage" expected or intended from the standpoint of the insured. This exclusion does not apply to "bodily injury" or "property damage" resulting from the use of reasonable force to protect persons or property.

2. Non-owned Watercraft

Exclusion 2.g. (2) (a) is replaced with the following:

- (a) Less than 51 feet long; and

3. Property Damage Liability – Borrowed Equipment

The following is added to Exclusion 2.j. (4):

Paragraph (4) of this exclusion does not apply to "property damage" to borrowed equipment while at a jobsite and not being used to perform operations. The most we will pay for "property damage" to any one borrowed equipment item under this coverage is \$25,000 per "occurrence". The insurance afforded under this provision is excess over any other valid and collectible property insurance (including deductible) available to the insured, whether primary, excess, contingent or on any other basis.

4. Limited Electronic Data Liability

Exclusion 2.p. is replaced with the following:

- p. Electronic Data

Damages arising out of the loss of, loss of use of, damage to, corruption of, inability to access, or inability to manipulate "electronic data" that does not result from physical injury to tangible property.

The most we will pay under Coverage A for "property damage" because of all loss of "electronic data" arising out of any one "occurrence" is \$10,000.

We have no duty to investigate or defend claims or "suits" covered by this Limited Electronic Data Liability coverage.

The following definition is added to **SECTION V – DEFINITIONS** of the Coverage Form:

"Electronic data" means information, facts or programs stored as or on, created or used on, or transmitted to or from computer software (including systems and applications software), hard or floppy disks, CD-ROMS, tapes, drives, cells, data processing devices or any other media which are used with electronically controlled equipment.

For purposes of this **Limited Electronic Data Liability** coverage, the definition of "Property Damage" in **SECTION V – DEFINITIONS** of the Coverage Form is replaced by the following:

17. "Property damage" means:

- a. Physical injury to tangible property, including all resulting loss of use of that property. All such loss of use shall be deemed to occur at the time of the physical injury that caused it;
- b. Loss of use of tangible property that is not physically injured. All such loss of use shall be deemed to occur at the time of the "occurrence" that caused it;
- c. Loss of, loss of use of, damage to, corruption of, inability to access, or inability to properly manipulate "electronic data", resulting from physical injury to tangible property. All such loss of "electronic data" shall be deemed to occur at the time of the "occurrence" that caused it.

For purposes of this insurance, "electronic data" is not tangible property.

SECTION I – COVERAGES, COVERAGE B. PERSONAL AND ADVERTISING INJURY LIABILITY is amended as follows:

Paragraph 2.e. Exclusions – the Contractual Liability Exclusion is deleted.

SECTION I – COVERAGES, the following coverages are added:

COVERAGE D. VOLUNTARY PROPERTY DAMAGE

1. Insuring Agreement

We will pay, at your request, for "property damage" caused by an "occurrence", to property of others caused by you, or while in your possession, arising out of your business operations. The amount we will pay for damages is described in SECTION III LIMITS OF INSURANCE.

2. Exclusions

This insurance does not apply to:

"Property Damage" to:

- a. Property at premises owned, rented, leased or occupied by you;
- b. Property while in transit;
- c. Property owned by, rented to, leased to, loaned to, borrowed by, or used by you;
- d. Premises you sell, give away, or abandon, if the "property damage" arises out of any part of those premises;
- e. Property caused by or arising out of the "products-completed operations hazard";
- f. Motor vehicles;
- g. "Your product" arising out of it or any part of it; or
- h. "Your work" arising out of it or any part of it.

3. Deductible

We will not pay for loss in any one "occurrence" until the amount of loss exceeds \$250. We will then pay the amount of loss in excess of \$250 up to the applicable limit of insurance.

4. Cost Factor

In the event of a covered loss, you shall, if requested by us, replace the damaged property or furnish the labor and materials necessary for repairs thereto at your actual cost, excluding profit or overhead charges.

The insurance afforded under COVERAGE D is excess over any other valid and collectible property or inland marine insurance (including the deductible applicable to the property or inland marine coverage) available to you whether primary, excess, contingent or any other basis.

Coverage D covers unintentional damage or destruction, but does not cover disappearance, theft, or loss of use.

The insurance under COVERAGE D does not apply if a loss is paid under COVERAGE E.

COVERAGE E. CARE, CUSTODY OR CONTROL

1. Insuring Agreement

We will pay those sums that the insured becomes legally obligated to pay as damages because of "property damage" caused by an "occurrence", to property of others while in your care, custody, or control or property of others as to which you are exercising physical control if the "property damage" arises out of your business operations. The amount we will pay for damages is described in SECTION III LIMITS OF INSURANCE.

2. Exclusions

This insurance does not apply to:

"Property Damage" to:

- a. Property at premises owned, rented, leased or occupied by you;
- b. Property while in transit;
- c. Premises you sell, give away, or abandon, if the "property damage" arises out of any part of those premises;
- d. Property caused by or arising out of the "products-completed operations hazard";
- e. Motor vehicles;
- f. "Your product" arising out of it or any part of it; or
- g. "Your work" arising out of it or any part of it.

3. Deductible

We will not pay for loss in any one "occurrence" until the amount of loss exceeds \$250. We will then pay the amount of loss in excess of \$250 up to the applicable limit of insurance.

4. Cost Factor

In the event of a covered loss, you shall, if requested by us, replace the damaged property or furnish the labor and materials necessary for repairs thereto at your actual cost, excluding profit or overhead charges.

The insurance afforded under COVERAGE E is excess over any other valid and collectible property or inland marine insurance (including the deductible applicable to the property or inland marine coverage) available to you whether primary, excess, contingent or any other basis.

The insurance under COVERAGE E does not apply if a loss is paid under COVERAGE D.

COVERAGE F. LIMITED PRODUCT WITHDRAWAL EXPENSE

1. Insuring Agreement

- a. If you are a "seller", we will reimburse you for "product withdrawal expenses" associated with "your product" incurred because of a "product withdrawal" to which this insurance applies.

The amount of such reimbursement is limited as described in SECTION III - LIMITS OF INSURANCE. No other obligation or liability to pay sums or perform acts or services is covered.

- a. This insurance applies to a "product withdrawal" only if the "product withdrawal" is initiated in the "coverage territory" during the policy period because:
 - (1) You determine that the "product withdrawal" is necessary; or
 - (2) An authorized government entity has ordered you to conduct a "product withdrawal".
- c. We will reimburse only those "product withdrawal expenses" which are incurred and reported to us within one year of the date the "product withdrawal" was initiated.
- d. The initiation of a "product withdrawal" will be deemed to have been made only at the earliest of the following times:
 - (1) When you have announced, in any manner, to the general public, your vendors or to your employees (other than those employees directly involved in making the determination) your decision to conduct a "product withdrawal" This applies regardless of whether the determination to conduct a "product withdrawal" is made by you or is requested by a third party;
 - (2) When you received, either orally or in writing, notification of an order from an authorized government entity to conduct a "product withdrawal"; or
 - (3) When a third party has initiated a "product withdrawal" and you communicate agreement with the "product withdrawal", or you announce to the general public, your vendors or to your employees (other than those employees directly involved in making the determination) your decision to participate in the "product withdrawal", whichever comes first.
- e. "Product withdrawal expenses" incurred to withdraw "your products" which contain:
 - (1) The same "defect" will be deemed to have arisen out of the same "product withdrawal"; or
 - (2) A different "defect" will be deemed to have arisen out of a separate "product withdrawal" if newly determined or ordered in accordance with paragraph 1.b of this coverage.

2. Exclusions

This insurance does not apply to "product withdrawal" expenses" arising out of:

- a. Any "product withdrawal" initiated due to:
 - (1) The failure of "your products" to accomplish their intended purpose, including any breach of warranty of fitness, whether written or implied. This exclusion does not apply if such failure has caused or is reasonably expected to cause "bodily injury" or physical damage to tangible property.
 - (2) Copyright, patent, trade secret or trademark infringements;
 - (3) Transformation of a chemical nature, deterioration or decomposition of "your product", except if it is caused by:
 - (a) An error in manufacturing, design, processing or transportation of "your product"; or
 - (b) "Product tampering".
 - (4) Expiration of the designated shelf life of "your product".
- b. A "product withdrawal", initiated because of a "defect" in "your product" known to exist by the Named Insured or the Named Insured's "executive officers", prior to the inception date of this Coverage Part or prior to the time "your product" leaves your control or possession.
- c. Recall of any specific products for which "bodily injury" or "property damage" is excluded under Coverage A - Bodily Injury And Property Damage Liability by endorsement.
- d. Recall of "your products" which have been banned from the market by an authorized government entity prior to the policy period.
- e. The defense of a claim or "suit" against you for "product withdrawal expenses".

3. For the purposes of the insurance afforded under COVERAGE F, the following is added to 2. Duties In The Event Of Occurrence, Offense, Claim Or Suit Condition under SECTION IV – COMMERCIAL GENERAL LIABILITY CONDITIONS:

e. Duties In The Event Of A "Defect" Or A "Product Withdrawal"

- (1) You must see to it that we are notified as soon as practicable of any actual, suspected or threatened "defect" in "your products", or any governmental investigation, that may result in a "product withdrawal". To the extent possible, notice should include:
 - (a) How, when and where the "defect" was discovered;
 - (b) The names and addresses of any injured persons and witnesses; and
 - (c) The nature, location and circumstances of any injury or damage arising out of use or consumption of "your product".
- (2) If a "product withdrawal" is initiated, you must:
 - (a) Immediately record the specifics of the "product withdrawal" and the date it was initiated;
 - (b) Send us written notice of the "product withdrawal" as soon as practicable; and
 - (c) Not release, consign, ship or distribute by any other method, any product, or like or similar products, with an actual, suspected or threatened defect.
- (3) You and any other involved insured must:
 - (a) Immediately send us copies of pertinent correspondence received in connection with the "product withdrawal";
 - (b) Authorize us to obtain records and other information; and
 - (c) Cooperate with us in our investigation of the "product withdrawal".

4. For the purposes of this Coverage F, the following definitions are added to the Definitions Section:

- a. "Defect" means a defect, deficiency or inadequacy that creates a dangerous condition.
- b. "Product tampering" is an act of intentional alteration of "your product" which may cause or has caused "bodily injury" or physical injury to tangible property.

When "product tampering" is known, suspected or threatened, a "product withdrawal" will not be limited to those batches of "your product" which are known or suspected to have been tampered with.

- c. "Product withdrawal" means the recall or withdrawal of "your products", or products which contain "your products", from the market or from use, by any other person or organization, because of a known or suspected "defect" in "your product", or a known or suspected "product tampering", which has caused or is reasonably expected to cause "bodily injury" or physical injury to tangible property.
- d. "Product withdrawal expenses" means those reasonable and necessary extra expenses, listed below paid and directly related to a "product withdrawal":
 - (1) Costs of notification;
 - (2) Costs of stationery, envelopes, production of announcements and postage or facsimiles;
 - (3) Costs of overtime paid to your regular non-salaried employees and costs incurred by your employees, including costs of transportation and accommodations;
 - (4) Costs of computer time;
 - (5) Costs of hiring independent contractors and other temporary employees;
 - (6) Costs of transportation, shipping or packaging;
 - (7) Costs of warehouse or storage space; or

(8) Costs of proper disposal of "your products", or products that contain "your products", that cannot be reused, not exceeding your purchase price or your cost to produce the products; but "product withdrawal expenses" does not include costs of the replacement, repair or redesign of "your product", or the costs of regaining your market share, goodwill, revenue or profit.

- e. "Seller" means a person or organization that manufactures, sells or distributes goods or products. "Seller" does not include a "contractor" as defined elsewhere in this endorsement.

The insurance under COVERAGE F does not apply if a loss is paid under COVERAGE G.

COVERAGE G. CONTRACTORS ERRORS AND OMISSIONS

1. Insuring Agreement

If you are a "contractor", we will pay those sums that you become legally obligated to pay as damages because of "property damage" to "your product", "your work" or "impaired property", due to faulty workmanship, material or design, or products including consequential loss, to which this insurance applies. The damages must have resulted from your negligent act, error or omission while acting in your business capacity as a contractor or subcontractor or from a defect in material or a product sold or installed by you while acting in this capacity. The amount we will pay for damages is described in SECTION III LIMITS OF INSURANCE.

We have no duty to investigate or defend claims or "suits" covered by this Contractors Errors or Omissions coverage.

This coverage applies only if the "property damage" occurs in the "coverage territory" during the policy period.

This coverage does not apply to additional insureds, if any.

Supplementary Payments – Coverage A and B do not apply to Coverage G. Contractors Errors and Omissions.

2. Exclusions

This insurance does not apply to:

- a. "Bodily injury" or "personal and advertising injury".
- b. Liability or penalties arising from a delay or failure to complete a contract or project, or to complete a contract or project on time.
- c. Liability because of an error or omission:
 - (1) In the preparation of estimates or job costs;
 - (2) Where cost estimates are exceeded;
 - (3) In the preparation of estimates of profit or return on capital;
 - (4) In advising or failure to advise on financing of the work or project; or
 - (5) In advising or failing to advise on any legal work, title checks, form of insurance or suretyship.
- d. Any liability which arises out of any actual or alleged infringement of copyright or trademark or trade dress or patent, unfair competition or piracy, or theft or wrongful taking of concepts or intellectual property.
- e. Any liability for damages:
 - (1) From the intentional dishonest, fraudulent, malicious or criminal acts of the Named Insured, or by any partner, member of a limited liability company, or executive officer, or at the direction of any of them; or
 - (2) Which is in fact expected or intended by the insured, even if the injury or damage is of a different degree or type than actually expected or intended.

- f. Any liability arising out of manufacturer's warranties or guarantees whether express or implied.
- g. Any liability arising from "property damage" to property owned by, rented or leased to the insured.
- h. Any liability incurred or "property damage" which occurs, in whole or in part, before you have completed "your work." "Your work" will be deemed completed at the earliest of the following times:
 - (1) When all of the work called for in your contract or work order has been completed;
 - (2) When all the work to be done at the job site has been completed if your contract calls for work at more than one job site; or
 - (3) When that part of the work done at a job site has been put to its intended use by any person or organization other than another contractor or subcontractor working on the same project.Work that may need service or maintenance, correction, repair or replacement, but which is otherwise complete, will be treated as complete.
- i. Any liability arising from "property damage" to products that are still in your physical possession.
- j. Any liability arising out of the rendering of or failure to render any professional services by you or on your behalf, but only with respect to either or both of the following operations:
 - (1) Providing engineering, architectural or surveying services to others; and
 - (2) Providing or hiring independent professionals to provide engineering, architectural or surveying services in connection with construction work you perform.Professional services include the preparing, approving or failing to prepare or approve, maps, shop drawings, opinions, reports, surveys, field orders, change orders, or drawings and specifications. Professional services also include supervisory or inspection activities performed as part of any related architectural or engineering activities.
But, professional services do not include services within construction means, methods, techniques, sequences and procedures employed by you in connection with construction work you perform.
- k. Your loss of profit or expected profit and any liability arising therefrom.
- l. "Property damage" to property other than "your product," "your work" or "impaired property."
- m. Any liability arising from claims or "suits" where the right of action against the insured has been relinquished or waived.
- n. Any liability for "property damage" to "your work" if the damaged work or the work out of which the damage arises was performed on your behalf by a subcontractor.
- o. Any liability arising from the substitution of a material or product for one specified on blueprints, work orders, contracts or engineering specifications unless there has been written authorization, or unless the blueprints, work orders, contracts or engineering specifications were written by you, and you have authorized the changes.
- p. Liability of others assumed by the insured under any contract or agreement, whether oral or in writing. This exclusion does not apply to liability for damages that the insured would have in the absence of the contract or agreement.

3. For the purposes of Coverage G, the following definition is added to the Definitions section:

- a. "Contractor" means a person or organization engaged in activities of building, clearing, filling, excavating or improvement in the size, use or appearance of any structure or land. "Contractor" does not include a "seller" as defined elsewhere in this endorsement.

4. Deductible

We will not pay for loss in any one "occurrence" until the amount of loss exceeds \$250. The limits of insurance will not be reduced by the application of the deductible amount.

We may pay any part or all of the deductible amount to effect settlement of any claim or "suit", and upon notification of the action taken, you shall promptly reimburse us for such part of the deductible amount as has been paid by us.

5. Cost Factor

In the event of a covered loss, you shall, if requested by us, replace the damaged property or furnish the labor and materials necessary for repairs thereto at your actual cost, excluding profit or overhead charges.

The insurance under COVERAGE G does not apply if a loss is paid under COVERAGE F.

COVERAGE H. LOST KEY COVERAGE

1. Insuring Agreement

We will pay those sums, subject to the limits of liability described in SECTION III LIMITS OF INSURANCE in this endorsement and the deductible shown below, that you become legally obligated to pay as damages caused by an "occurrence" and due to the loss or mysterious disappearance of keys entrusted to or in the care, custody or control of you or your "employees" or anyone acting on your behalf. The damages covered by this endorsement are limited to the:

- a. Actual cost of the keys;
- b. Cost to adjust locks to accept new keys; or
- c. Cost of new locks, if required, including the cost of installation.

2. Exclusions

This insurance does not apply to:

- a. Keys owned by any insured, employees of any insured, or anyone acting on behalf of any insured;
- b. Any resulting loss of use; or
- c. Any of the following acts by any insured, employees of any insured, or anyone acting on behalf of any insured:
 - 1) Misappropriation;
 - 2) Concealment;
 - 3) Conversion;
 - 4) Fraud; or
 - 5) Dishonesty.

3. Deductible

We will not pay for loss in any one "occurrence" until the amount of loss exceeds \$1,000. The limits of insurance will not be reduced by the application of the deductible amount.

We may pay any part or all of the deductible amount to effect settlement of any claim or "suit" and, upon notification of the action taken, you shall promptly reimburse us for such part of the deductible amount as has been paid by us.

EXPANDED COVERAGE FOR TENANT'S PROPERTY AND PREMISES RENTED TO YOU

The first paragraph after subparagraph (6) in Exclusion j., Damage to Property is amended to read as follows:

Paragraphs (1), (3) and (4) of this exclusion do not apply to "property damage" (other than damage by fire) to premises, including the contents of such premises, rented to you. A separate limit of insurance applies to Damage To Premises Rented To You as described in Section III – Limits Of Insurance.

SECTION I - COVERAGES, SUPPLEMENTARY PAYMENTS – COVERAGE A and B is amended as follows:

All references to SUPPLEMENTARY PAYMENTS – COVERAGES A and B are amended to SUPPLEMENTARY PAYMENTS – COVERAGES A, B, D, E, G, and H.

1. Cost of Bail Bonds

Paragraph 1.b. is replaced with the following:

- b. Up to \$2,500 for cost of bail bonds required because of accidents or traffic law violations arising out of the use of any vehicle to which the Bodily Injury Liability Coverage applies. We do not have to furnish these bonds.

2. Loss of Earnings

Paragraph 1.d. is replaced with the following:

- d. All reasonable expenses incurred by the insured at our request to assist us in the investigation or defense of the claim or “suit”, including actual loss of earnings up to \$500 a day because of time off from work.

SECTION II – WHO IS AN INSURED is amended as follows:

1. Incidental Malpractice

Paragraph 2.a.(1)(d) is replaced with the following:

- (d) Arising out of his or her providing or failing to provide professional health care services. However, this exclusion does not apply to a nurse, emergency medical technician or paramedic employed by you to provide medical services, unless:
 - (i) You are engaged in the occupation or business of providing or offering medical, surgical, dental, x-ray or nursing services, treatment, advice or instruction; or
 - (ii) The “employee” has another insurance that would also cover claims arising under this provision, whether the other insurance is primary, excess, contingent or on any other basis.

2. Broadened Who Is An Insured

The following are added to Paragraph 2.:

Subsidiaries

- e. Your subsidiaries if:
 - (1) They are legally incorporated entities; and
 - (2) You own more than 50% of the voting stock in such subsidiaries as of the effective date of this policy. If such subsidiaries are not shown in the Declarations, you must report them to us within 180 days of the inception of your original policy.

Additional Insureds

- f. Any person or organization described in paragraphs g. through k. below whom you are required to add as an additional insured on this policy under a written contract or agreement in effect during the term of this policy, provided the written contract or agreement was executed prior to the “bodily injury”, “property damage” or “personal and advertising injury” for which the additional insured seeks coverage.

However, the insurance afforded to such additional insured(s):

- (1) Only applies to the extent permitted by law;
- (2) Will not be broader than that which you are required by the contract or agreement to provide for such additional insured;
- (3) Will not be broader than that which is afforded to you under this policy;
- (4) Is subject to the conditions described in paragraphs g. through k. below; and
- (5) Nothing herein shall extend the term of this policy.

g. **Owner, Lessor or Manager of Premises**

If the additional insured is an owner, lessor or manager of premises, such person or organization shall be covered only with respect to liability arising out of the ownership, maintenance or use of that part of any premises leased to you and subject to the following additional exclusions:

- (1) Any "occurrence" that takes place after you cease to occupy those premises; or
- (2) Structural alterations, new construction or demolition operations performed by or on behalf of such person or organization.

h. **State or Governmental Agency or Subdivision or Political Subdivision – Permits or Authorizations**

If the additional insured is the state or any political subdivision, the state or political subdivision shall be covered only with respect to operations performed by you or on your behalf for which the state or political subdivision has issued a permit or authorization. This insurance does not apply to:

- (1) "Bodily injury", "property damage", or "personal and advertising injury" arising out of operations performed for the federal government, state or municipality; or
- (2) "Bodily injury" or "property damage" included within the "products-completed operations hazard".

i. **Lessor of Leased Equipment**

If the additional insured is a lessor of leased equipment, such lessor shall be covered only with respect to liability for "bodily injury", "property damage" or "personal and advertising injury" caused, in whole or in part, by your maintenance, operation or use of equipment leased to you by such person(s) or organization(s). With respect to the insurance afforded to these additional insureds, this insurance does not apply to any "occurrence" which takes place after the equipment lease expires.

j. **Mortgagee, Assignee, or Receiver**

If the additional Insured is a mortgagee, assignee, or receiver of premises, such mortgagee, assignee or receiver of premises is an additional insured only with respect to their liability as mortgagee, assignee, or receiver and arising out of the ownership, maintenance, or use of the premises by you. This insurance does not apply to structural alterations, new construction and demolition operations performed by or for that person or organization.

k. **Vendor**

If the additional insured is a vendor, such vendor is an additional insured only with respect to "bodily injury" or "property damage" caused by "your products" which are distributed or sold in the regular course of the vendor's business, subject to the following additional exclusions:

- (1) The insurance afforded to the vendor does not apply to:
 - (a) "Bodily injury" or "property damage" for which the vendor is obligated to pay damages by reason of the assumption of liability in a contract or agreement. This exclusion does not apply to liability for damages that the vendor would have in absence of the contract or agreement.
 - (b) Any express warranty unauthorized by you;
 - (c) Any physical or chemical change in "your product" made intentionally by the vendor;
 - (d) Repackaging, unless unpacked solely for the purpose of inspection, demonstration, testing, or the substitution of parts under instructions from the manufacturer, and then repackaged in the original container;
 - (e) Any failure to make such inspections, adjustments, tests or servicing as the vendor has agreed to make or normally undertakes to make in the usual course of business, in connection with the distribution or sale of the products;
 - (f) Demonstration, installation, servicing or repair operations, except such operations performed at the vendor's premises in connection with the sale of the product;

- (g) Products which, after distribution or sale by you, have been labeled or relabeled or used as a container, part or ingredient of any other thing or substance by or for the vendor; or
- (h) "Bodily injury" or "property damage" arising out of the sole negligence of the vendor for its own acts or omissions or those of its own acts or omissions or those of its employees or anyone else acting on its behalf. However, this exclusion does not apply to:
 - i. The exceptions contained in Subparagraphs d. or f.; or
 - ii. Such inspections, adjustments, tests or servicing as the vendor has agreed to make or normally undertakes to make in the usual course of business, in connection with the distribution or sale of the products.

(2) This insurance does not apply to any insured person or organization, from whom you have acquired such products, or any ingredient, part or container, entering into, accompanying or containing such products.

3. Newly Formed or Acquired Organizations

Paragraph 3. is amended as follows:

- a. Coverage under this provision is afforded until the end of the policy period.
- d. Coverage A does not apply to product recall expense arising out of any withdrawal or recall that occurred before you acquired or formed the organization.

SECTION III – LIMITS OF INSURANCE is amended as follows:

1. Paragraph 2. is replaced with the following:

- 2. The General Aggregate Limit is the most we will pay for the sum of:
 - a. Medical expenses under Coverage C;
 - b. Damages under Coverage A, except damages because of "bodily injury" or "property damage" included in the "products-completed operations hazard";
 - c. Damages under Coverage B;
 - d. Voluntary "property damage" payments under Coverage D;
 - e. Care, Custody or Control damages under Coverage E.; and
 - f. Lost Key Coverage under Coverage H.

2. Paragraph 5. is replaced with the following:

- 5. Subject to Paragraph 2. or 3. above, whichever applies, the Each Occurrence Limit is the most we will pay for the sum of:
 - a. Damages under Coverage A;
 - b. Medical expenses under Coverage C;
 - c. Voluntary "property damage" payments under Coverage D;
 - d. Care, Custody or Control damages under Coverage E;
 - e. Limited Product Withdrawal Expense under Coverage F;
 - f. Contractors Errors and Omissions under Coverage G.; and
 - g. Lost Key Coverage under Coverage H.

because of all "bodily injury" and "property damage" arising out of any one "occurrence".

3. Paragraph 6. is replaced with the following:

- 6. Subject to Paragraph 5. above the Damage To Premises Rented To You Limit is the most we will pay under Coverage A for damages because of "property damage" to any one premises, while rented to you,

or in the case of damage by fire or explosion, while rented to you or temporarily occupied by you with permission of the owner.

The Damage to Premises Rented to You Limit is the higher of the Each Occurrence Limit shown in the Declarations or the amount shown in the Declarations as Damage To Premises Rented To You Limit.

4. Paragraph 7. is replaced with the following:

7. Subject to Paragraph 5. above, the higher of \$10,000 or the Medical Expense Limit shown in the Declarations is the most we will pay under Coverage C for all medical expenses because of "bodily injury" sustained by any one person.

5. Paragraph 8. is added as follows:

8. Subject to Paragraph 5. above, the most we will pay under Coverage D. Voluntary Property Damage for loss arising out of any one "occurrence" is \$1,500. The most we will pay in any one-policy period, regardless of the number of claims made or suits brought, is \$3,000.

6. Paragraph 9. is added as follows:

9. Subject to Paragraph 5. above, the most we will pay under Coverage E. Care, Custody or Control for "property damage" arising out of any one "occurrence" is \$1,000. The most we will pay in any one-policy period, regardless of the number of claims made or suits brought, is \$5,000.

7. Paragraph 10. is added as follows:

10. Subject to Paragraph 5. above, the most we will pay under Coverage F. Limited Product Withdrawal Expense for "product withdrawal expenses" in any one-policy period, regardless of the number of insureds, "product withdrawals" initiated or number of "your products" withdrawn is \$10,000.

8. Paragraph 11. is added as follows:

11. Subject to Paragraph 5. above, the most we will pay under Coverage G. Contractors Errors and Omissions for damage in any one-policy period, regardless of the number of insureds, claims or "suits" brought, or persons or organizations making claim or bringing "suits" is \$10,000.

For errors in contract or job specifications or in recommendations of products or materials to be used, this policy will not pay for additional costs of products and materials to be used that would not have been incurred had the correct recommendations or specifications been made.

9. Paragraph 12. is added as follows:

12. Subject to Paragraph 5. above, the most we will pay under Coverage H., Lost Key Coverage for damages arising out of any one occurrence is \$50,000.

10. Paragraph 13. is added as follows:

13. The General Aggregate Limit applies separately to:

- a. Each of your projects away from premises owned by or rented to you; or
- b. Each "location" owned by or rented to you.

"Location" as used in this paragraph means premises involving the same or connecting lots, or premises whose connection is interrupted only by a street, roadway, waterway or right-of-way of a railroad.

11. Paragraph 14. is added as follows:

14. With respect to the insurance afforded to any additional insured provided coverage under this endorsement:

If coverage provided to the additional insured is required by a contract or agreement, the most we will pay on behalf of the additional insured is the amount of insurance:

- a. Required by the contract or agreement; or

- b. Available under the applicable Limits of Insurance shown in the Declarations;
whichever is less.

This endorsement shall not increase the applicable Limits of Insurance shown in the Declarations.

SECTION IV – COMMERCIAL GENERAL LIABILITY CONDITIONS is amended as follows:

1. Subparagraph 2.a. of Duties In The Event Of Occurrence, Offense, Claim, or Suit is replaced with the following:

- a. You must see to it that we are notified as soon as practicable of an “occurrence” or an offense which may result in a claim. This requirement applies only when the “occurrence” or offense is known to the following:
- (1) An individual who is the sole owner;
 - (2) A partner, if you are a partnership or joint venture;
 - (3) An “executive officer” or insurance manager, if you are a corporation;
 - (4) A manager, if you are a limited liability company;
 - (5) A person or organization having proper temporary custody of your property if you die;
 - (6) The legal representative of you if you die; or
 - (7) A person (other than an “employee”) or an organization while acting as your real estate manager.

To the extent possible, notice should include:

- (1) How, when and where the “occurrence” or offense took place;
- (2) The names and addresses of any injured persons and witnesses; and
- (3) The nature and location of any injury or damage arising out of the “occurrence” or offense.

2. The following is added to Subparagraph 2.b. of Duties In The Event Of Occurrence, Offense, Claim, or Suit:

The requirement in 2.b.applies only when the “occurrence” or offense is known to the following:

- (1) An individual who is the sole owner;
- (2) A partner or insurance manager, if you are a partnership or joint venture;
- (3) An “executive officer” or insurance manager, if you are a corporation;
- (4) A manager or insurance manager, if you are a limited liability company;
- (5) Your officials, trustees, board members or insurance manager, if you are a not-for-profit organization;
- (6) A person or organization having proper temporary custody of your property if you die;
- (7) The legal representative of you if you die; or
- (8) A person (other than an “employee”) or an organization while acting as your real estate manager.

3. The following is added to paragraph 2. of Duties in the Event of Occurrence, Offense, Claim or Suit:

- e. If you report an “occurrence” to your workers compensation carrier that develops into a liability claim for which coverage is provided by the Coverage Form, failure to report such an “occurrence” to us at the time of the “occurrence” shall not be deemed a violation of paragraphs a., b., and c. above. However, you shall give written notice of this “occurrence” to us as soon as you become aware that this “occurrence” may be a liability claim rather than a workers compensation claim.

4. Paragraph 6. is replaced with the following:

6. Representations

By accepting this policy, you agree:

- a. The statements in the Declarations are accurate and complete;
- b. Those statements are based upon representations you made to us; and
- c. We have issued this policy in reliance upon your representations.

Any error or omission in the description of, or failure to completely describe or disclose any premises, operations or products intended to be covered by the Coverage Form will not invalidate or affect coverage for those premises, operations or products, provided such error or omission or failure to completely describe or disclose premises, operations or products was not intentional.

You must report such error or omission to us as soon as practicable after its discovery. However, this provision does not affect our right to collect additional premium charges or exercise our right of cancellation or nonrenewal.

5. The following is added to paragraph 8. Transfer Of Rights Of Recovery Against Others To Us:

However, we waive any right of recovery we may have because of payments we make for injury or damage arising out of your ongoing operations or "your work" included in the "products-completed operations hazard" under the following conditions:

- a) Only when you have agreed in writing to waive such rights of recovery in a contract or agreement;
- b) Only as to the person/entity as to whom you are required by the contract to waive rights of recovery; and
- c) Only if the contract or agreement is in effect during the term of this policy, and was executed by you prior to the loss.

6. Paragraph 10. is added as follows:

10. Liberalization

If we revise this Coverage Form to provide more coverage without additional premium charge, your policy will automatically provide the additional coverage as of the day the revision is effective in the applicable state(s).

1. Give us written notice of an "occurrence" or an offense which may result in a claim or "suit" under this insurance, and of any claim or "suit" that does result;
2. Send us copies of all legal papers received in connection with the claim or "suit", cooperate with us in the investigation or settlement of the claim or defense against the "suit", and otherwise comply with all policy conditions; and
3. Tender the defense and indemnity of any claim or "suit" to any provider of other insurance which would cover the additional insured for a loss we cover under this endorsement and agree to make available all such other insurance. However, this condition does not affect Paragraph C. above.

We have no duty to defend or indemnify an additional insured under this endorsement until we receive from the additional insured written notice of a claim or "suit".

- F. This endorsement does not apply to any additional insured or project that is specifically identified in any other additional insured endorsement attached to the Commercial General Liability Coverage Form.

File Attachments for Item:

8. Approval of contract with the Coastal Regional Commission to provide technical assistance and planning services.

**CONTRACT FOR PROFESSIONAL SERVICES
COMPREHENSIVE PLAN UPDATE**

This contract is made by and between the Coastal Regional Commission, hereinafter referred to as the “CRC,” and City of Tybee Island hereinafter referred to as “the City.”

Witnesses that:

WHEREAS, The City desires that the CRC provide technical assistance and planning services hereinafter referred to as “professional planning services.”

THEREFORE, it is distinctly understood and mutually agreed as follows:

- I. PERFORMANCE OF SERVICES:** The City agrees to engage the CRC and the CRC hereby agrees to perform the services stipulated in this agreement in accordance with the terms and conditions contained herein.
- A. The contract shall commence upon execution by all parties, and terminate on October 31, 2021.
 - B. The City agrees that its officials and employees shall cooperate with the CRC in the discharge of the CRC’s responsibilities under this contract and shall be available for consultation at such times as may be mutually agreeable to all parties. The City officials shall be responsible for ensuring that all data, reports, plans, ordinances, records, maps, and other information shall be made available to the CRC as needed/requested to perform necessary planning functions.
 - C. The CRC’s performance is directly dependent on cooperation of City officials and timeliness in submitting materials specified in the contract. The materials provided to the CRC shall be complete, accurate, and in the format requested. Should information not be provided to the CRC in a timely manner, the project completion date may be extended, which in turn, may increase the project cost.
 - D. The CRC shall consider the receipt of this contract, signed and executed, as the official notice to proceed.
- II. SCOPE OF WORK:** The CRC shall perform and complete in a satisfactory manner the following services:
- A. The CRC shall provide professional planning services in accordance with applicable sections of the State Planning Requirements, and any applicable state rules and regulations, local statutes, ordinances in accordance with the professional standards of skill and diligence.
 - B. The CRC shall host a Kick-Off **Public Hearing** with **City Council** to explain planning process to the community and receive preliminary input and have Community Stakeholders assigned.

- C. The CRC shall host workshop(s) to discuss and prioritize the preliminary **Community Goals** to identify the community's direction and to serve as a guide for implementation.
- D. The CRC shall process the public, and Stakeholder input and feedback.
- E. The CRC shall host workshop(s) with community stakeholders to create a list of **Needs and Opportunities** with a **SWOT** analysis to be followed up with implementation measures in the **Community Work Program**.
- F. The CRC shall provide professional planning in accordance with the Rules of the GA Department of Community Affairs, (DCA) Chapter 110-12-1, Minimum Standards and Procedures for Local Comprehensive and provide planning assistance for the following **Required and Optional Plan Elements**:
 - i. Broadband Services Element required for all local governments.
 - ii. Capital Improvement Element for local governments that charge impact fees.
 - iii. Economic Development Element for communities seeking improved economic opportunities
 - iv. Land Use Element for communities with zoning or land development regulations subject to the Zoning Procedures.
 - v. Transportation Element for communities interested in adding alternative transportation facilities for pedestrians, bicyclists and public transportation users.
 - vi. Housing Element for entitlement communities and communities with job-housing imbalance or dilapidated housing.
- G. A number of documents, including, but not limited to, existing ordinances, master plans, Service Delivery Strategy, current comprehensive plan and work program, current budget and staff contact list, are requested by the CRC at the beginning of the planning process to be referenced as needed.
- H. The CRC shall notify interested parties of the availability of the Comprehensive Plan for review and comment.
- I. The CRC shall transmit a report of the DCA finding and recommendations to the City.
- J. The CRC shall forward the adoption resolution to DCA.

III. SERVICES PROVIDED BY THE CITY: The City shall furnish data and provide assistance on tasks as follows:

- A. Identification of Stakeholders – The City shall compile a list of stakeholders. Members of the governing authority must be included among stakeholders and be actively involved in such as serving on the steering committee.

- B. The City must form a steering committee to oversee and participate and include members of the governing authority, local economic development practitioners and local government staff.
- C. First Required Public Hearing – a first public hearing must be held at the inception of the planning process. The purpose of this hearing is to brief the community on the process and to obtain input.
- D. Second Public Hearing – In accordance with the GA Department of Community Affairs, (DCA) Chapter 110-12-1, Minimum Standards and Procedures for Local Comprehensive Planning, a second public hearing must be held once the Plan has been drafted and made available for public review. The purpose is to brief the community on the contents of the Plan, provide opportunity for final suggestions. Once comments have been addressed, the Plan must be transmitted to the CRC.
- E. The transmittal must include the City’s certification that it considered the Regional Water Plan and Environmental Planning Criteria.
- F. The City must adopt the approved plan and provide a copy of the adoption resolution to the CRC.
- G. The City may designate a Representative trained and knowledgeable as the primary contact.

IV. COMPENSATION: The City shall compensate the CRC for services performed in accordance with Section II *Scope of Work* of this contract.

- A. The CRC shall conduct professional planning services specified in Section II of this contract. The CRC shall provide Required Plan Elements (C&E) in accordance with the GA Department of Community Affairs, (DCA) Chapter 110-12-1, Minimum Standards and Procedures for Local Comprehensive Planning.
- B. The CRC shall conduct professional planning services specified in Section II, specifically as required and/or optional elements of this contract.
- C. The CRC shall invoice the City on a quarterly basis for all hours and expenses incurred in performance of its obligations under this contract.
- D. The City shall compensate the CRC for conducting the services specified in Section II of this contract in an amount of \$7,200 (seven thousand two hundred dollars).
 - a. The CRC will not invoice the City in excess of the amount stated above without first obtaining written approval of the City.

Payment of invoices is due within thirty (30) days of the date of each invoice. Invoices shall be submitted to The County, Attn: Shawn Gillen, City Manager, Post Office Box 2749, Tybee Island GA 31328. Payments shall be made to Coastal Regional Commission, Attn: Lena Geiger, Finance Director located at 1181 Coastal Dr., SW Darien, GA 31305.

V. SCHEDULE: The CRC anticipates commencing work upon receiving notice to proceed.

- VI. OBJECTIVITY OF RECOMMENDATIONS:** The City understands that the CRC shall make recommendations based on its best professional abilities. Both to protect The City and to assure that the CRC's work shall continue to be accepted as objective and impartial, it is understood that the CRC's fee for the work under this project is not dependent on any specific conclusions.
- VII. NONCOMPLIANCE, MODIFICATION, OR ABROGATION:** In the event of the CRC's and/or the City's noncompliance with the requirements of this contract, this contract may be canceled, terminated or suspended in whole or part.
- A. Either party may terminate this Contract without cause by giving the other party thirty (30) days written notice.
 - B. If this contract is nullified, all finished or unfinished documents prepared by the CRC under this contract shall, at the discretion of The City become the City's property.
 - C. The CRC shall be entitled to compensation for any work completed on said project.
 - D. All modifications and changes to the contract shall be in writing. E-mail and fax communications shall be considered legal and binding correspondence. The original scope of the project, or the completion date, may be altered by either party with written concurrence by both the CRC and the City. Such changes shall be specifically designated as a "Change Order" and shall be signed by both parties. The CRC is not authorized or obligated to undertake any work under a "Change Order" until that "Change Order" is signed by both parties. Upon issuing a "Change Order", The County shall assure the CRC that there are sufficient funds to cover the additional cost, if any, of the changes to the original scope of the project.
 - E. A written notice shall be submitted by the CRC to The City immediately should any invoice submitted for payment be outstanding greater than fifteen (15) days.
- VIII. OWNERSHIP OF DOCUMENTS:** All documents developed by the CRC as a result of this contract shall become the property of the City.
- IX. CONFIDENTIALITY:** Any report, information, data, etc., given to, prepared or assembled by the CRC, under this Contract, will not be made available to any individual or organization without the prior written approval of the City.
- X. INDEMNIFICATION:** The City shall indemnify and hold harmless the CRC and its subcontractors, employees, agents, and representatives from and against any and all suits, additions, legal proceedings, claims, demands, damages, liabilities, costs and expenses, including attorney's fees arising out or in connection with or claimed to arise out of or in connection with any negligent or wrongful error, omission or act of the CRC or anyone acting in its behalf in connection with or incident to this contract, or as a result of any work product of the CRC.

XI. PROJECT CONTACTS:

Eric Landon
Planning & Government Services
Coastal Regional Commission
1181 Coastal Dr., SW
Darien, GA 31305

Shawn Gillen
City Manager
sgillen@cityoftybee.org
Post Office Box 2749
Tybee Island, GA 31328

CITY COUNCIL OF TYBEE ISLAND

Date

Name:

Title:

Date

Witness:

Title:

COASTAL REGIONAL COMMISSION

Date

Name: Allen Brown

Title: Chairman

Date

Name: Allen Burns

Title: Executive Director

Date

Witness:

Title:

File Attachments for Item:

10. Non-Award of ITB 2020-755, Memorial Pavilion due to budget restraints

MAYOR
Shirley Sessions

CITY COUNCIL
Barry Brown, Mayor Pro tem
John Branigin
Nancy DeVetter
Jay Burke
Monty Parks
Spec Hosti



CITY MANAGER
Shawn Gillen

CITY CLERK
Janet LeViner

CITY ATTORNEY
Edward M. Hughes

CITY OF TYBEE ISLAND

BID 2020-755

PROJECT Memorial Park Pavilion

DUE 10-27-20 2:00pm

<u>BIDDER</u>	<u>BID AMOUNT</u>	<u>NOTE</u>
1. E & D CONTRACTING SERVICES, LLC	\$200,000	NO ELECTRONIC COPY BID BOND & ADDENDUM
2. DASH COMPANY, LLC	—	BID BOND & NO ADDENDUM
3. CNB CONSTRUCTION	\$175,700	BID BOND & ADDENDUM
4. SPANNING CONSTRUCTION & MAINTENANCE	\$12,950	BID BOND & ADDENDUM
5. E.B. MORAN GENERAL CONTRACTORS	\$235,555	BID BOND & ADDENDUM
6.		
7.		
8.		
9.		
10.		
11.		
12.		

OPENED BY:

WITNESS:

P.O. Box 2749 – 403 Butler Avenue, Tybee Island, Georgia 31328-2749
(866) 786-4573 – FAX (866) 786-5737
www.cityoftybee.org

PROJECT MANUAL

INVITATION TO BID-
ITB NO. 2020-755

**CITY OF TYBEE ISLAND –
Renovation to Memorial Park Pavilion**

Tybee Island, GA

September 2020



PREPARED BY
GREENLINE ARCHITECTURE

28 E 35TH ST
SAVANNAH, GA 31401
T 912.447.5665
F 912.447.8381

**INVITATION TO BID
ITB NO. 2020-755**

**RENOVATION TO MEMORIAL PARK PAVILION
BID DUE: TUESDAY, OCTOBER 27, 2020 at 2:00pm**

CITY OF TYBEE ISLAND, GEORGIA

SHIRLEY SESSIONS, MAYOR

BARRY BROWN, MAYOR PRO TEM

SPEC HOSTI

MONTY PARKS

NANCY DEVETTER

JOHN BRANIGIN

JAY BURKE

DOCUMENT CHECK LIST

The following documents are contained in and made a part of this Invitation to Bid, or are required to be submitted with the bid. It is the responsibility of the Bidder to read, complete and sign, where indicated, and return these documents with his/her bid. **FAILURE TO DO SO MAY BE CAUSE FOR DISQUALIFICATION OF THE BIDDER**

[INTRODUCTION](#)

[SPECIFICATIONS AND REQUIREMENTS](#)

1. [INSTRUCTIONS TO BIDDERS](#)
2. [GENERAL INFORMATION](#)
3. [BID AND PERFORMANCE BOND](#)

[ATTACHMENTS:](#) A. SIGNATURE SHEET; B. CONTRACTOR AFFIDAVIT; C. SUBCONTRACTOR AFFIDAVIT; D. SAVE AFFIDAVIT; E. VENDOR INFORMATION; F. DEBARMENT CERTIFICATION G. BID FORM; H. CHECKLIST

[SEPARATE ATTACHMENT:](#) 1. PROJECT PLANS

INTRODUCTION

This is an invitation to bid to supply the City of Tybee Island, Georgia with products or services as indicated herein.

Sealed bids must be received by 2:00pm local time, on Tuesday, October 27, 2020, at which time and place all bids received will be publicly opened and read aloud. The City of Tybee Island reserves the right to reject any or all bids.

METHOD OF AWARD: If the City of Tybee Island awards a contract from this ITB, it will be awarded to the responsible bidder with the lowest responsive bid. Bidders must respond completely by filling in all applicable blanks.

Signature of bidder indicates understanding and compliance with the terms of this request, the requirements herein, and any subsequent award or contract. All specifications, conditions, and representations made in this ITB will become an integral part of the contract. Nothing contained within this ITB is indicative of intent by the City of Tybee Island to reimburse the bidder, in whole or in part, for any costs associated with preparation, submission, or presentation of bids.

Instructions for preparation and submission of a bid are contained in this ITB package. Please note that specific forms for submission of a bid are required.

The City of Tybee Island has an equal opportunity purchasing policy to assure all procurement procedures are conducted in a manner that provides maximum open and free competition. The City seeks to ensure that all segments of the business community have access to supplying the goods and services needed by the City. The City provides equal opportunity for all businesses and does not discriminate against any persons or businesses regardless of race, color, religion, age, sex, national origin or handicap.

The City is seeking a bid package for service or materials equal to or exceeding specifications set forth on the attached pages. Bidders not meeting these standards will be rejected. The attached specifications become and remain a part of this ITB.

All responses, inquiries, or correspondence relating to, or in reference to, this ITB, and all reports, charts, displays, schedules, exhibits and other documentation by the bidders will become the property of the City when received. The City retains the right to use any or all ideas presented in any response to this ITB, whether amended or not. Selection or rejection of the bid does not affect this right.

SPECIFICATIONS AND REQUIREMENTS

1. INSTRUCTIONS TO BIDDERS

Purpose: The purpose of this document is to provide general and specific information for use in submitting a bid to supply the City of Tybee Island with equipment, supplies, and/or services as described herein. All ITBs are governed by the Code of the City of Tybee Island, Georgia, 15-2015 Sec 1, Art VII, Procurement, Sec 2-400, and the laws of the State of Georgia.

Bidders must carefully review all provisions of, and attachments to, this document prior to submission. Each bid constitutes an offer and cannot be withdrawn except as provided herein. This ITB and any attachments, plans, and/or other related documents can be found on the City's website at <https://www.cityoftybee.org/Bids.aspx>. It is incumbent upon the bidder to check the website for additional information and/or addendums.

1.1 How to Prepare Bids:

All Bids must be:

- a. Prepared on the forms enclosed herewith, unless otherwise prescribed, and **all documents must be submitted.**
- b. Bids must be signed by the business owner or authorized representative, with all erasures or corrections initialed and dated by the official signing the Bid. **ALL SIGNATURE SPACES MUST BE SIGNED.**

One original, and one electronic copy (usb flash drive) must be submitted in a sealed opaque envelope, plainly marked with the ITB number and title, and bidder's company name, to the office of the address below prior to the time specified. Include all required attachments, which can be found at the end of this document.

- **Include all requested documents, including required bid bond. See Attachment H**
- **City/County Occupational Tax Certificate Requirement: Contractor must supply a copy of their Occupational Tax Certificate as proof of payment of the occupational tax where their office is located. In addition, if a contract is awarded, contractors that are not located on Tybee Island are required to obtain a Tybee Island contractor registration. Contact Sharon Shaver for additional information, at 912-472-5072, or in person at Tybee Island City Hall 403 Butler Ave, Tybee Island, Ga**

All Bids must be hand delivered, mailed, or sent by courier in sufficient time to ensure receipt by the Purchasing Agent on or before the time and date specified above. Include Vendor Name and ITB #2020-755/ Renovation to Memorial Park Pavilion on front of envelope.

- **Courier or hand deliver bid package to:**

**MELISSA FREEMAN
TYBEE ISLAND CITY HALL
403 BUTLER AVE
TYBEE ISLAND, GA. 31328**

- **Bids may be submitted via US Mail, but bidders choosing this method should allow *at least* an additional 24 hours for delivery:**

**MELISSA FREEMAN
CITY OF TYBEE ISLAND
PO BOX 2749
TYBEE ISLAND, GA. 31328**

FAXED OR E-MAILED COPIES WILL NOT BE CONSIDERED. BIDS NOT RECEIVED BY THE TIME AND DATE SPECIFIED WILL NOT BE OPENED.

1.3 How to Submit an Objection:

Potential bidders must present any written objection to this ITB at least seven (7) days prior to the bid due date. The objections contemplated may pertain to form and/or substance of the ITB documents. Objections must be made in writing to the Purchasing agent, Melissa Freeman mfreeman@cityoftybee.org. Email subject line: Objection to ITB #2020-755.

1.4 Errors in ITB responses:

Bidders are expected to fully inform themselves as to the conditions, requirements, and specifications of this ITB before submitting a bid. Failure to do so will be at the Bidder's own risk. In case of error in extension of prices in bid, the unit price will govern.

1.5 Questions concerning ITB:

Questions, inquiries, suggestions, or requests concerning interpretation, clarification or additional information concerning any portion of this ITB must be made by email, sent to the below named individual, who will be the official point of contact for this ITB. Questions must be submitted at least seven days before the bid due date.

Mark subject line on e-mail “**Questions on ITB 2020-755 - Renovation to Memorial Park Pavilion**”

POINT OF CONTACT:

Peter Gulbranson

peter.gulbranson@cityoftybee.org

Failure of a Bidder to ask questions, request changes, or submit objections by the dates indicated above shall constitute the Bidder's acceptance of all of the terms, conditions and requirements set forth in this ITB.

1.6 Addendums to ITB:

Any changes to the conditions or specifications in this ITB must be in the form of a written addendum to be valid. If the City of Tybee Island issues an addendum to this ITB, it will be posted by the Purchasing Agent on the City's website.

The issuance of a written addendum by the Purchasing Agent is the only official method by which interpretation, clarification or additional information will be given. The City of Tybee Island will not be responsible for any oral representation given by any employee, representative or others.

Bidder must acknowledge each addendum in the bid. **It is solely your responsibility as a bidder to ensure that you have received all addenda and incorporated the changes into your bid response before submission.** Unless otherwise specified in an addendum, the due date and time remains as listed above.

2 GENERAL INFORMATION

2.1 Specifications:

Any obvious error or omission in specifications will not inure to the benefit of the bidder but will put the bidder on notice to inquire of or identify the same from the City of Tybee Island. Whenever herein mention is made of any article, material or workmanship to be in accordance with laws, ordinances, building codes, underwriter's codes, A.S.T.M. regulations or similar expressions, the requirements of these laws, ordinances, etc., will be construed to be the minimum requirements of these specifications.

2.2 Standards for Acceptance of Bid for Contract Award:

City of Tybee Island reserves the right to reject any or all bids and to waive any irregularities or technicalities in bids received whenever such rejection or waiver is in the best interest of City of Tybee Island. City of Tybee Island reserves the right to reject the bid of a bidder who has previously failed to perform properly or complete on time

contracts of a similar nature, or a bid from a bidder whom investigation shows is not in a position to perform the contract.

- 2.3 Bidder:** Whenever the term "bidder" is used it will encompass the "person," "business," "supplier," "vendor," or other party submitting a bid (a binding offer) to the City of Tybee Island in such capacity before a contract has been entered into between such party and the City of Tybee Island.
- 2.4 Responsible / Responsive bidder:** *Responsible bidder* means a person or entity that has the capability in all respects to perform fully and reliably the contract requirements. *Responsive bidder* means a person or entity that has submitted a bid that conforms in all material respects to the requirements set forth in this ITB.
- 2.5 Multiple Bids:** No Vendor will be allowed to submit more than one (1) bid.
- 2.6 Compliance with Laws:** The bidder will obtain and maintain all licenses, permits, liability insurance, worker's compensation insurance and comply with any and all other standards or regulations required by federal, state, county or city statute, ordinances and rules during the performance of any contract between the contractor and City of Tybee Island. Any such requirement specifically set forth in any contract document between the contractor and City of Tybee Island will be supplementary to this section and not in substitution thereof.
- 2.7 Contractor:** Contractor or subcontractor means any person or business having a contract with City of Tybee Island. The Contractor/Vendor of goods, material, equipment or services certifies that they will follow equal employment opportunity practices in connection with the awarded contract as more fully specified in the contract documents.
- 2.8 State Licensing Board for General Contractors:** If applicable, pursuant to Georgia law, any bidder must be a Georgia licensed **General Contractor** (Contractor work or activity that is unlimited in scope regarding any residential or commercial projects).
- 2.9 Security & Immigration Compliance:** On 1 July 2007, the Georgia Security and Immigration Compliance Act (SB 529, Section 2) became effective. All contractors and subcontractors entering into a contract or performing work must sign an affidavit that he/she has used the E-Verify System. E-Verify is a no-cost federal employment verification system to insure employment eligibility. **No bids will be considered unless a signed E-Verify Affidavit is enclosed with the submittal package.**

Affidavits are enclosed in this solicitation. You may download M-274 Handbook for Employers at <http://www.dol.state.ga.us/spotlight/employment/rules>. You may go to <http://www.uscis.gov> to find the E-Verify information.

Systematic Alien Verification for Entitlements (SAVE) Program: O.C.G.A. 50-36-1 required Georgia cities to comply with the federal **Systematic Alien Verification for Entitlements (SAVE) Program**. SAVE is a federal program used to verify that applicants for certain "public benefits" are legally present in the United States. Contracts with the City are considered "public benefits." Responders are required to provide the Affidavit Verifying Status for City of Tybee Benefit Application prior to receiving any City contract. The affidavit is included as part of this ITB package.

Protection of Resident Workers. City of Tybee Island actively supports the Immigration and Nationality Act (INA), which includes provisions addressing employment eligibility employment verification, and nondiscrimination. Under the INA, employers can hire only

persons who can legally work in the United States (i.e., citizens and nationals of the U.S.) and aliens authorized to work in the U.S. The employer must verify the identity and employment eligibility of any hiree, which includes completing the Employment Eligibility Verification Form (I-9). The Contractor will establish appropriate procedures and controls so no services or products under the Contract Documents will be performed or manufactured by any worker who is not legally eligible to perform such services or employment.

- 2.10 Permitting and Approvals:** The contractor that is awarded the contract will be responsible for securing all necessary federal, state and local approvals required for the project.
- 2.11 Prices to be Firm:** Bidder warrants that bid prices, terms and conditions quoted in his bid will be firm for acceptance for a period of sixty (60) days from bid opening date, unless otherwise stated in the ITB.
- 2.12 Quality:** All materials or supplies used for, or the workmanship employed in, any construction necessary to comply with this bid, will be of the best quality, and adhere to the highest industry standards.
- 2.13 Guarantee/Warranty:** Unless otherwise specified by the City of Tybee Island, the Bidder will unconditionally guarantee the materials and workmanship for one (1) year from completion of the project or delivery of goods. If, within the guarantee period, any defects occur which are due to faulty material and or services, the contractor, at his expense, will repair or adjust the condition, or replace the material, to comply with the contract requirements and applicable standards thereof. These repairs, replacements or adjustments will be made only at such time as will be designated by the City of Tybee Island as being least detrimental to the operation of the City.
- 2.14 Liability Provisions:** Where bidders are required to enter or go onto City of Tybee Island property to take measurements or gather other information in order to prepare the Bid as requested by the City, the bidder will be liable for any injury, damage or loss occasioned by negligence of the bidder, its agent, or any person the bidder has designated to prepare the bid and will indemnify and hold harmless City of Tybee Island from any liability arising there from. The contract document specifies the liability provisions required of the successful bidder in order to be awarded a contract with City of Tybee Island.
- 2.15 Cancellation of Contract:** The contract may be canceled or suspended by City of Tybee Island in whole or in part by written notice of default to the Contractor upon non-performance or violation of contract terms. An award may be made to the next lowest bidder, for articles and/or services specified or they may be purchased on the open market. The defaulting Contractor (or its surety) will be liable to City of Tybee Island for costs to the City of Tybee Island in excess of the defaulted contract prices. See the contract documents for complete requirements.
- 2.16 Certification of Independent Price Determination:** By submission of this bid, the Bidder certifies, and in the case of a joint bid each party thereto certifies as to its own organization, that in connection with this procurement:
- a. The prices in this bid have been arrived at independently, without consultation, communication, or agreement, for the purpose of restricting competition, as to any matter relating to such prices with any other bidder or with any competitor;
 - b. Unless otherwise required by law, the prices which have been quoted in this bid

have not been knowingly disclosed by the bidder and will not knowingly be disclosed by the bidder prior to opening, directly or indirectly to any other bidder or to any competitor; and

- c. No attempt has been made or will be made by the bidder to induce any other person or firm to submit or not to submit a bid for the purpose of restricting competition.

2.17 Qualification of Business (Responsible Bidder): the Scope of Work, specifications and plans define a responsible Bidder as one who meets, or by the date of the bid acceptance can meet, certifications, all requirements for licensing, insurance, and registrations, or other documentation required. The City has the right to require any or all bidders to submit documentation of the ability to perform, provide, or carry out the service or provide the product requested. The City has the right to disqualify the bid of any bidder as being unresponsive or un-responsible whenever such Bidder cannot document the ability to deliver the requested product or service.

2.18 Insurance Provisions, General: The selected proposer to whom the contract is awarded will be required to procure and maintain for the duration of the contract insurance against claims for injuries to persons or damages to property that may arise from, or in connection with, the performance of the work hereunder by the Contractor, his agents, representatives, employees or subcontractors. The cost of such insurance must be included in the proposal.

- a. General Information that must appear on a Certificate of Insurance:
 - i. Name of the Producer (proposer's insurance Broker/Agent).
 - ii. Companies affording coverage (there may be several).
 - iii. Name and Address of the Insured (this is the Company or Parent of the firm the City is contracting with).
 - iv. A Summary of all current insurance for the insured (includes effective dates of coverage).
 - v. A brief description of the operations to be performed, the specific job to be performed, and contract number.
 - vi. Certificate Holder (**Must include the City of Tybee Island as a certificate holder and an additional insured**).

THE INSURANCE CERTIFICATE IS TO IDENTIFY THE CITY OF TYBEE ISLAND AS A CERTIFICATE HOLDER AND AS AN ADDITIONAL INSURED FOR GENERAL, AUTO, UMBRELLA, AND EXCESS LIABILITY COVERAGES.

- b. Minimum Limits of Insurance to be maintained for the duration of the contract:
 - i. **Commercial General Liability:** Provides protection against bodily injury and property damage claims arising from operations of a Contractor. This policy coverage includes premises and operations, use of independent contractors, products/completed operations, personal injury, contractual, broad form property damage, and underground, explosion and collapse hazards. Minimum limits: **\$2,000,000** bodily injury and property damage per occurrence and annual aggregate.
 - ii. **Worker's Compensation and Employer's Liability:** Provides statutory protection against bodily injury, sickness or disease sustained by employees of the Contractor while performing within the scope of their duties. Employee Liability coverage is usually included in Worker's Compensation policies, and

insures common law claims of injured employees made in lieu of or in addition to a Worker's Compensation claim. Minimum limits: **\$500,000** for each accident, disease policy limit, and disease each employee and Statutory Worker's Compensation limit.

- iii. **Business Automobile Liability:** Coverage insures against liability claims arising out of the Contractor's use of automobiles. Minimum limit: **\$2,000,000** combined single limit per accident for bodily injury and property damage. Coverage must be written on an Any Auto basis.

THE INSURANCE REQUIREMENTS AND LIMITS STATED HEREIN MAY BE SATISFIED BY A COMBINATION OF PRIMARY, UMBRELLA &/OR EXCESS COVERAGES.

c. Special Requirements:

- i. **Extended Reporting Periods:** The Contractor must provide the City of Tybee Island with a notice of the election to initiate any Supplemental Extended Reporting Period and the reason(s) for invoking this option.
- ii. **Reporting Provisions:** Any failure to comply with reporting provisions of the policies will not affect coverage provided in relation to this request.
- iii. **Cancellation:** Each insurance policy that applies to this request must be endorsed to state that it will not be suspended, voided, or canceled, except after thirty (30) days prior to written notice by certified mail, return receipt requested, has been given to the City of Tybee Island.
- iv. **Proof of Insurance:** City of Tybee Island must be furnished with certificates of insurance and with original endorsements affecting coverage required by this request. The certificates and endorsements are to be signed by a person authorized by the insurer to bind coverage on its behalf. All certificates of insurance are to be submitted prior to, and approved by, the City of Tybee Island before services are rendered. The Contractor must ensure Certificate of Insurance is updated for the entire term of the City of Tybee Island contract.
- v. **Insurer Acceptability:** Insurance is to be placed with an insurer having an A.M. Best's rating of A and a five (5) year average financial rating of not less than V. If an insurer does not qualify for averaging on a five-year basis, the current total Best's rating will be used to evaluate insurer acceptability.
- vi. **Lapse in Coverage:** A lapse in coverage will constitute grounds for contract termination by the City of Tybee Island Mayor and Council.
- vii. **Deductibles and Self-Insured Retention:** Any deductibles or self-insured retention must be declared to, and approved by, the City of Tybee Island. At the option of the City of Tybee Island, either: the insurer will reduce or eliminate such deductibles or self-insured retention as related to the City of Tybee Island, its officials, officers, employees, and volunteers; or the Contractor will procure a bond guaranteeing payment of related suits, losses, claims, and related investigation, claim administration and defense expenses.

Conditions, Vendor's Bid, Addendum, and/or any other pertinent documents form a part of the Bid and by reference are made a part hereof.

2.20 Signed Bid Considered Offer: The signed Bid will be considered a binding offer on the part of the Bidder, which offer will be deemed accepted upon approval by the City of Tybee Island Mayor and Council, Purchasing Agent or designee, as may be applicable. In case of a default on the part of the Bidder after such acceptance, the City of Tybee Island may take such action as it deems appropriate, including legal action, for damages or lack of required performance.

2.21 Notice to Proceed: The successful bidder must not commence work under this ITB until a written contract is awarded and a Notice to Proceed is issued by the Purchasing Agent or his designee, or as specified in the Special Conditions. If the successful Bidder does commence any work or deliver items prior to receiving official notification, it does so at its own risk.

2.22 Protest Policy: Any bidder who is aggrieved in connection with the award of a contract may file a protest with the Purchasing Agent. The protest must be submitted in writing no later than 48 hours after the bid opening. Protests must be made in writing to the Purchasing agent, Melissa Freeman at mfreeman@cityoftybee.org, with the subject line Protest: ITB #2020-755, and must include the following information:

- a. Name, address, email address, and telephone numbers of the protester;
- b. ITB number;
- c. Detailed statement of the legal and factual grounds for the protest, including a description of resulting harm to the protester;
- d. Copies of supporting documents, if any;
- e. Statement of relief requested;
- f. All information establishing that the protester is an interested party for the purpose of filing a protest on an award decision;
- g. All information establishing the timeliness of the protest.

2.23 Payment to Contractors: Instructions for invoicing the City of Tybee Island for products delivered to the City are specified in the contract document.

- a. Questions regarding payment may be directed to the Accounting Department at 912-472-5024 or City of Tybee Island's Project Manager as specified in the contract documents.
- b. Contractors will be paid the agreed upon compensation upon satisfactory delivery of the products or completion of the work as more fully described in the contract document.
- c. Upon completion of the work or delivery of the products, the Contractor will provide the City of Tybee Island with an affidavit certifying all suppliers, persons or businesses employed by the Contractor for the work performed for the City of Tybee Island have been paid in full.
- d. City of Tybee Island is a tax-exempt entity. Every contractor, vendor, business or person under contract with City of Tybee Island is required by Georgia law to pay State sales or use taxes for products purchased in Georgia or transported into Georgia and sold to City of Tybee Island by contract. Please consult the State of Georgia, Department of Revenue, Sales and Use Tax Unit in Atlanta (404) 654-4065 for additional information.

2.24 City's Rights Concerning Award: The City reserves the right, and sole and complete discretion to waive technicalities and informalities. The City further reserves the right, and sole and complete discretion to reject all bids and any bid that is not responsive or that is over the budget, as amended, or that fails to suit the needs of the City as determined by the City in its sole discretion. In judging whether the Bidder is responsible, the City will consider, but is not limited to consideration of, the following:

- a. Whether the Bidder or principals are currently ineligible, debarred, suspended, or otherwise excluded from contracting by any state or federal agency, department, or authority;
- b. Whether the Bidder or principals have been terminated for cause or are currently in default on a public works contract;
- c. Whether the Bidder can demonstrate a commitment to safety with regard to Workers' Compensation by having an experience Modification Rate (EMR) over the past three years not having exceeded an average of 1.2; and
- d. Whether the Bidder's past work provides evidence of an ability to successfully complete public works projects within the established time, quality, or cost, or to comply with the Bidder's contract obligations.

2.25 Debarred or Suspended Subcontractors: Contractor will not subcontract, and will ensure that no subcontracts are awarded at any tier, to any individual, firm, partnership, joint venture, or any other entity regardless of the form of business organization, that is on the Federal Excluded Parties List System (EPLS) at <https://www.epls.gov> or the State of Georgia, DOAS, State Purchasing Exclusion listing, or other local government entity. This includes pending litigation or claims with the City or other government entities. Contractor will immediately notify City of Tybee Island in the event any subcontractor is added to a Federal, State or other Government Entity listing after award of the subcontract.

2.26 Cone of Silence: Lobbying of Procurement Evaluation Committee members, City employees, and elected officials regarding this product or service solicitation, Request for Proposal (RFP) or contract by any member of a proposer's staff, or those people employed by any legal entity affiliated with an organization that is responding to the solicitation is strictly prohibited. Negative campaigning through the mass media about the current service delivery is strictly prohibited. Such actions will cause render your proposal invalid. In order to conduct this procurement transaction in manner that provides full and open competition and meet the Federal Uniform Guidance Requirements to ensures objective contractor performance and eliminate unfair competitive advantage, contractors that develop or draft specifications, requirements, statement of work, or invitation for bids or request for proposal must be excluded from competing for this contract.

2.27 Georgia Open Records Act: The responses will become part of the City of Tybee Island's official files without any obligation on the City of Tybee Island's part. Ownership of all data, materials and documentation prepared for and submitted to City of Tybee Island in response to a solicitation, regardless of type, will belong exclusively to City of Tybee Island and will be considered a record prepared and maintained or received in the course of operations of a public office or agency and subject to public inspection in accordance with the Georgia Open Records Act, Official Code of Georgia Annotated, Section 50-18-70, et. Seq., unless otherwise provided by law.

contain trade secrets or other confidential matters. A Bidder submitting records which the entity or person believes contains trade secrets and that it wishes to keep such records confidential pursuant to O.C.G.A. § 50-19-72(34) will submit and attach to the records an affidavit affirmatively declaring that specific information in the records constitute trade secrets pursuant to Article 27 of Chapter 1 of Title 10 of the Official Code of Georgia. See also, section 2.27.

City of Tybee Island will not be held accountable if material from bids is obtained without the written consent of the bidder by parties other than the City of Tybee Island, at any time during the solicitation and evaluation process.

- 2.28 Georgia Trade Secret Act of 1990:** In the event a Bidder submits trade secret information to the City of Tybee Island, the information must be clearly labeled as a Trade Secret. The City of Tybee Island will maintain the confidentiality of such trade secrets to the extent provided by law.
- 2.29 Contractor Records:** The Georgia Open Records Act is applicable to the records of all contractors and subcontractors under contract with the City of Tybee Island. This applies to those specific contracts currently in effect and those that have been completed or closed for up three (3) years following completion.
- 2.30 Method of Compensation:** The compensation provided for herein will include all claims by the contractor for all costs incurred by the contractor in the conduct of the Project as authorized by the approved Project Compensation Schedule and this amount will be paid to the contractor after receipt of the invoice and approval of the amount by the City of Tybee Island. The City will make payments to the contractor within thirty (30) days from the date of receipt of the contractor's acceptable statement on forms prepared by the contractor and approved by the City of Tybee Island.

Should the Project begin within any one month, the first invoice will cover the partial period from the beginning date of the Project through the last day of the month (or on a mutually agreeable time) in which it began. The invoices will be submitted each month until the Project is completed. Invoices will be itemized to reflect actual expenses for each individual task; also refer to the requirements concerning changes, delays and termination of work pursuant to provisions of the contract. Each invoice will be accompanied by a summary progress report, which outlines the work accomplished during the billing period and any problems that may be inhibiting the Project execution. The terms of this contract are intended to supersede all provisions of the Georgia Prompt Pay Act.

As long as the gross value of completed work is less than 50% of the total contract amount, or if the contractor is not maintaining his construction schedule to the satisfaction of the engineer, the City of Tybee Island will retain 10% of the gross value of the completed work as indicated by the current estimate approved by the engineer acting on behalf of the City of Tybee Island.

After the gross value of completed work becomes to or exceed 50% of the total contract amount within a time period satisfactory to the City of Tybee Island, then the total amount to be retained will be reduced to 5% of the gross value of the completed work as indicated by the current estimate approved by the engineer, until all pay items are substantially completed.

When all work is completed and time charges have ceased, pending final acceptance and final payment the amount retained will be further reduced at the discretion of the City Tybee Island.

The Contractor may submit a final invoice to the City of Tybee Island for the remaining retainage upon City's acceptance of the Certificate of Substantial Completion. Final payment constituting the entire unpaid balance due will be paid by the City to the Contractor when work has been fully completed and the contract fully performed, except for the responsibilities of the Contractor which survive final payment. The making of final payment will constitute a waiver of all claims by the City except those arising from unsettled liens, faulty or defective work appearing after substantial completion, failure of the work to comply with the requirements of the Contract Documents, or terms of any warranties required by the Contractor Documents or those items previously made in writing and identified by the City as unsettled at the time of final application for payment. Acceptance of final payment will constitute a waiver of all claims by the Contractor, except those previously made in writing and identified by the Contractor as unsettled at the time of final application for payment.

2.31 Terms of Contract:

a. ONE TIME CONTRACT

2.32 Audits and Inspections: The contractor and his subcontractors will make available to the City of Tybee Island for examination of all its records with respect to all matters covered by this Contract. It will also permit the City of Tybee Island and/or representatives of the Finance Department to audit, inspect, examine and make copies, excerpts or transcripts from such records of personnel, conditions of employment and other data relating to all matters covered by this Contract. All documents to be audited will be available for inspection between 8am and 5pm in the main offices of the City of Tybee Island or during normal business hours at the offices of the Contractor, as requested by the City of Tybee Island.

2.33 Liquidated Damages: The project is to be completed by **April 1, 2021**. The City and Contractor recognize that time is of the essence of this Agreement and that the City will suffer financial loss if the work is not completed within the times specified in the contract, plus any extensions thereof allowed. The parties also recognize the damages or loss caused by the failure to complete the work on time is difficult or impossible to accurately estimate, and the parties hereby stipulate that the sum of One Thousand Dollars (\$1,000) per day is a reasonable pre-estimate of the probable damages or loss incurred by City for delay in completion of construction. Accordingly, the City and Contractor agree that as liquidated damages for delay, Contractor shall be liable to the City for the sum of One Thousand dollars (\$1,000.00) for each day that the work is not completed as specified in the contract and that this amount of liquidated damages is intended to solely provide for damages incurred by the City and not as a penalty to Contractor.

2.34 Bid Surety: Each proposal must be accompanied by a Proposal/Bid Bond, issued by a surety company licensed to do business under the laws of the State of Georgia, and satisfactory to the City of Tybee Island in the amount of five percent (5%) of the total contract amount to ensure the Contractor's satisfactory performance. Proposer will forfeit this amount should it be offered a contract by the City and refuse or fail to promptly enter into such contract.

3. BID AND PERFORMANCE BONDS:

a. Prior to the Agreement being signed, the Contractor shall furnish to the City of Tybee Island a Performance Bond issued by a surety company licensed to do business under the laws of the State of Georgia and satisfactory to the City of Ty

Island in the amount of one-hundred-percent (100%) of the total contract amount to ensure the Contractor's satisfactory performance.

- b. Also prior to the Agreement being signed, the Contractor shall furnish to the City of Tybee Island a Payment Bond issued by a surety company licensed to do business under the laws of the State of Georgia and satisfactory to the City of Tybee Island in the amount of one-hundred-percent (100%) of the total contract amount to ensure the Contractor's satisfactory payment of subcontractors and material suppliers.
- c. The Contractor shall be solely responsible for keeping the surety informed as to the total contract price, significant changes in project scope, and overall progress and completion of project for the entire life of the contract.
- d. If the surety on the bonds furnished by the Contractor is declared bankrupt or becomes insolvent, or its right to do business in the State of Georgia is terminated, the Contractor shall within five (5) calendar days thereafter substitute other bonds and surety acceptable to the City of Tybee Island. If the Contractor does not furnish the replacement bonds to the City of Tybee Island within the five (5) days, the City of Tybee Island may consider the Contractor in material breach of contract and take appropriate actions.

ATTACHMENT A

CITY OF TYBEE - INSTRUCTIONS TO BIDDER SIGNATURE SHEET

The Bidder certifies that he/she has examined all documents contained in this ITB package, and is familiar with all aspects of the ITB and understands fully all that is required of the successful Bidder. The Bidder further certifies that his/her Bid will not be withdrawn for sixty (60) days from the date on which his bid is submitted to the City.

The Bidder agrees, if awarded this Contract, he/she will:

A. Furnish, upon receipt of an authorized City of Tybee Island Purchase Order, all items indicated thereon as specified in this ITB for the bid amount; or,

B. Enter a contract with City of Tybee Island to do and/or furnish everything necessary to provide the service and/or accomplish the work as stated and/or specified in this ITB for the bid amount, and;

COMPANY

DATE

SIGNATURE

TITLE

TELEPHONE NUMBER

MINORITY/FEMALE BUSINESS DEVELOPMENT PROGRAM: City of Tybee Island City Council established goals oriented to increase participation of minority and female owned businesses, through MBE/WBE certification and development. In order to accurately document participation, businesses submitting bids, quotes or proposals are encouraged to report ownership status. A minority or women business is defined as a business that is at least 51% owned and managed by minority or women.

A responder that is certified by any agency of the Federal Government or State of Georgia may submit a copy of their certification with their bid as proof of qualifications. Bidder that intends to engage in joint ventures or utilize sub-consultants must submit a report of Minority/Women Business Enterprise participation to Melissa Freeman, P.O. Box 2749, and City of Tybee Island, GA 31328.

African-American\Black____ **Asian American**____ **Hispanic**____ **Native American**____

Alaskan Indian____ **Female**____

ATTACHMENT B

CONTRACTOR AFFIDAVIT under O.C.G.A. § 13-10-91(b) (1)

By executing this affidavit, the undersigned contractor verifies its compliance with O.C.G.A. § 13-10-91, stating affirmatively that the individual, firm or corporation which is engaged in the physical performance of services on behalf of CITY OF TYBEE ISLAND has registered with, is authorized to use and uses the federal work authorization program commonly known as E-Verify, or any subsequent replacement program, in accordance with the applicable provisions and deadlines established in O.C.G.A. § 13-10-91. Furthermore, the undersigned contractor will continue to use the federal work authorization program throughout the contract period and the undersigned contractor will contract for the physical performance of services in satisfaction of such contract only with subcontractors who present an affidavit to the contractor with the information required by O.C.G.A. § 13-10-91(b). Contractor hereby attests that its federal work authorization user identification number and date of authorization are as follows:

Federal Work Authorization User Identification Number

Date of Authorization

Name of Contractor

Name of Project

Name of Public Employer

I hereby declare under penalty of perjury that the foregoing is true and correct.

Executed on _____, ____, 201__ in _____ (city), _____ (state).

Signature of Authorized Officer or Agent

Printed Name and Title of Authorized Officer or Agent

SUBSCRIBED AND SWORN BEFORE ME ON THIS THE ___ DAY OF _____, 20__.

NOTARY PUBLIC

My Commission Expires: _____

ATTACHMENT C
(Due only if contract is awarded)

Subcontractor Affidavit under O.C.G.A. § 13-10-91(b)(3)
(Subcontractor Affidavits will be due at time of contract award)

By executing this affidavit, the undersigned subcontractor verifies its compliance with O.C.G.A. § 13-10-91, stating affirmatively that the individual, firm or corporation which is engaged in the physical performance of services under a contract with _____ (name of contractor) on behalf of _____ (name of public employer) has registered with, is authorized to use and uses the federal work authorization program commonly known as E-Verify, or any subsequent replacement program, in accordance with the applicable provisions and deadlines established in O.C.G.A. § 13-10-91. Furthermore, the undersigned subcontractor will continue to use the federal work authorization program throughout the contract period and the undersigned subcontractor will contract for the physical performance of services in satisfaction of such contract only with sub-subcontractors who present an affidavit to the subcontractor with the information required by O.C.G.A. § 13-10-91(b). Additionally, the undersigned subcontractor will forward notice of the receipt of an affidavit from a sub-subcontractor to the contractor within five business days of receipt. If the undersigned subcontractor receives notice that a sub- subcontractor has received an affidavit from any other contracted sub-subcontractor, the undersigned subcontractor must forward, within five business days of receipt, a copy of the notice to the contractor. Subcontractor hereby attests that its federal work authorization user identification number and date of authorization are as follows:

Federal Work Authorization User Identification Number

Date of Authorization

Name of Subcontractor

Name of Project

Name of Public Employer

I hereby declare under penalty of perjury that the foregoing is true and correct.

Executed on _____, 20__ in _____ city), ____ (state).

Signature of Authorized Officer or Agent

Printed Name and Title of Authorized Officer or Agent

SUBSCRIBED AND SWORN BEFORE ME
ON THIS THE _____ DAY OF _____, 20__.

NOTARY PUBLIC

Item #10. My Commission Expires:

ATTACHMENT D

O.C.G.A. § 50-36-1(e)(2) Affidavit

By executing this affidavit under oath, as an applicant for a(n) _____ contract for a public benefit as referenced in O.C.G.A. § 50-36-1, from the CITY OF TYBEE ISLAND, Georgia, the undersigned applicant verifies one of the following with respect to my application for a public benefit:

- 1) _____ I am a United States citizen.
- 2) _____ I am a legal permanent resident of the United States.
- 3) _____ I am a qualified alien or non-immigrant under the Federal Immigration and Nationality Act with an alien number issued by the Department of Homeland Security or other federal immigration agency.

My alien number issued by the Department of Homeland Security or other federal immigration agency is:_____.

The undersigned applicant also hereby verifies that he or she is 18 years of age or older and has provided at least one secure and verifiable document, as required by O.C.G.A. § 50-36-1(e)(1), with this affidavit.

The secure and verifiable document provided with this affidavit can best be classified as:
_____.

In making the above representation under oath, I understand that any person who knowingly and willfully makes a false, fictitious, or fraudulent statement or representation in an affidavit will be guilty of a violation of O.C.G.A. § 16-10-20, and face criminal penalties as allowed by such criminal statute.

Executed in _____ (city), _____(state).

Signature of Applicant

Printed Name of Applicant

SUBSCRIBED AND SWORN BEFORE ME ON THE ___ DAY OF _____, 20___

NOTARY PUBLIC
My Commission Expires:

ATTACHMENT E

CITY OF TYBEE ISLAND VENDOR INFORMATION

Vendor Name: _____

Product or Services Provided: _____

Sales Contact Information

Contact: _____ Email: _____

Phone: _____ Fax: _____

Address:

Accounts Receivable Information

Contact: _____ Email: _____

Phone: _____ Fax: _____

Remittance Address: _____

Federal Tax Id #: _____

Attach Copy of W-9 and Occupational Tax Certificate

Provide Copy of Worker's Comp Coverage when providing any service involving labor on City property.
Our terms are net 30

ATTACHMENT F
CERTIFICATION REGARDING DEBARMENT

INSTRUCTIONS FOR CERTIFICATION REGARDING DEBARMENT, SUSPENSION, INELIGIBILITY AND VOLUNTARY EXCLUSION:

By signing and submitting this bid, the prospective lower tier participant is providing the signed certification set out below.

1. The certification referred to in this paragraph is a material representation of fact upon which reliance was placed when this transaction was entered into. If it is later determined that the prospective lower tier participant knowingly rendered an erroneous certification, in addition to other remedies available to the Federal Government, the City of Tybee Island may pursue available remedies, including suspension and/or debarment.
2. The prospective lower tier participant shall provide immediate written notice to the City if at any time the prospective lower tier participant learns that its certification was erroneous when submitted or has become erroneous by reason of changed circumstances.
3. The terms “covered transaction,” “debarred,” “suspended,” “ineligible,” “lower tier covered participant,” “persons,” “lower tier covered transaction,” “principal,” “bid,” and “voluntarily excluded,” as used in this paragraph, have the meanings set out in the Definitions and Coverage sections of rules implementing Executive Order 12549, 49 CFR part 29.
4. The prospective lower tier participant agrees by submitting this bid that, should the proposed covered transaction be entered into, it shall not knowingly enter into any lower tier covered transaction with a person who is debarred, suspended, declared ineligible, or voluntarily excluded from participation in this covered transaction, unless authorized in writing by the City.
5. The prospective lower tier participant further agrees by submitting this bid that it will include the clause titled “Certification Regarding Debarment, Suspension, Ineligibility and Voluntary Exclusion — Lower Tier Covered Transaction,” without modification, in all lower tier covered transactions and in all solicitations for lower tier covered transactions.
6. A participant in a covered transaction may rely upon certification of a prospective participant in a lower tier covered transaction that it is not debarred, suspended, ineligible, or voluntarily excluded from the covered transaction, unless it knows that the certification is erroneous. A participant may decide the method and frequency by which it determines the eligibility of its principles. Each participant may, but is not required to, check the Nonprocurement List issued by U.S. General Service Administration.
7. Nothing contained in the foregoing shall be construed to require establishment of a system of records in order to render in good faith the certification required by this paragraph. The knowledge and information of a participant is not required to exceed that which is normally possessed by a prudent person in the ordinary course of business dealings.

8. Except for transactions authorized under paragraph 4 of these instructions, if a participant in a covered transaction knowingly enters into a lower tier covered transaction with a person who is suspended, debarred, ineligible, or voluntarily excluded from participation in this transaction, in addition to other remedies available to the Federal Government, the City may pursue available remedies, including suspension and/or debarment.

NAME OF COMPANY: _____

COMPANY TAX ID: _____

NAME OF AUTHORIZED REPRESENTATIVE: _____

TITLE OF AUTHORIZED REPRESENTATIVE: _____

SIGNATURE: _____ DATE: _____

**ATTACHMENT G
BID SHEET
ITB 2020-755
Renovation to Memorial Park Pavilion**

Please attach all specifications regarding materials, installation, and warranties to this sheet with your total bid cost below.

TOTAL BID including contractor fees: _____

_____ **(Firm)**

_____ **(Signature)**

_____ **(Title)**

_____ **(Date)**

ATTACHMENT H

CHECKLIST FOR SUBMITTING BID

Sign below and submit this sheet with your bid

NOTE: All of the following items must be submitted with your bid to be considered “responsive”. Remember to follow the Instructions in the ITB Documents.

ACKNOWLEDGMENT OF ANY/ALL ADDENDUMS _____

W-9 _____

OCCUPATIONAL TAX CERTIFICATE _____

BID BOND _____

COMPLETE AND SUBMIT ALL ATTACHMENTS TO THE BID:

A. SIGNATURE SHEET _____

B. CONTRACTOR AFFIDAVIT _____

D. SAVE AFFIDAVIT _____

E. VENDOR INFORMATION _____

F. DEBARMENT CERTIFICATION _____

G. BID SHEET _____

H. CHECKLIST _____

NAME/TITLE

COMPANY NAME

ADDRESS

CITY/STATE/ZIP

PHONE NUMBER

EMAIL

SIGNATURE

DATE

TABLE OF CONTENTS

SECTION No. SECTION TITLE

SECTION No. SECTION TITLE

003000 TABLE OF CONTENTS

DIVISION 1 - GENERAL REQUIREMENTS

----- **INTRODUCTION**
----- **SPECIFICATIONS AND REQUIREMENTS**
 1. INSTRUCTIONS TO BIDDERS
 2. GENERAL INFORMATION
 3. BID AND PERFORMANCE BOND

011000 SUMMARY AND ALTERNATES

DIVISION 2 – SITEWORK

023610 TERMITE CONTROL

DIVISION 4 – MASONRY

NOT USED

DIVISION 6 - WOOD AND PLASTICS

061600 SHEATHING

DIVISION 7 – THERMAL AND MOISTURE PROTECTION

074113 METAL ROOFING
074610 CEMENT SIDING

DIVISION 8 - OPENINGS

NOT USED

DIVISION 9 - FINISHES

099000 GENERAL FINISHES
099113 PAINTING

SECTION 011000 – SUMMARY

PART 1 - GENERAL

1.1 RELATED DOCUMENTS

- A. Drawings and general provisions of the Contract, including General and Supplementary Conditions and other Division 01 Specification Sections, apply to this Section.

1.2 SUMMARY

- A. Section includes:
 - 1. Project information.
 - 2. Work covered by Contract Documents.

1.3 PROJECT INFORMATION

- A. Project Identification: City of Tybee Island, Renovations to the Memorial Park Pavilion
 - 1. Project Location: 506 Jones Ave, Tybee Island , Georgia 31328
- B. Owner: City Of Tybee Island
 - 1. Owner's Representative: Pete Gulbranson
- C. Architect: Greenline Architecture, Keith Howington, Project Manager, (912)629-5030
- D. Other Owner Consultants: The Owner has retained the following design professionals who have prepared designated portions of the Contract Documents:
 - 1. Structural Engineer: Tharpe Engineering, Cody Tharpe

1.4 WORK COVERED BY CONTRACT DOCUMENTS

- A. The Work of the Project is defined by the Contract Documents and consists of the following:
 - 1. Project includes new framing and new roofing over existing column layout. All columns to remain unless deteriorated. Deteriorated columns/materials removed and replaced in kind. Electrical panels to be reused and all electrical outlets moved to above flood elevation AE10 + 1foot = 11 BFE.

2. Project will be constructed under a single prime contract.
3. The Work shall be conducted in a single phase.

- B. Before commencing Work, submit a copy of the Contractor's construction schedule showing the sequence, commencement and completion dates proposed. Submit updated schedules so that the Owner can coordinate move-in dates of Owner's personnel

1.5 WORK BY OWNER

- A. General: Cooperate fully with Owner so work may be carried out smoothly, without interfering with or delaying work under this Contract or work by Owner. Coordinate the Work of this Contract with work performed by Owner.
- B. Subsequent Work: Owner will perform the following additional work at site after Substantial Completion. Completion of that work will depend on successful completion of preparatory work under this Contract.

1.6 ACCESS TO SITE

- A. General: Contractor shall have limited use of Project site for construction operations as indicated on Drawings by the Contract limits and as indicated by requirements of this Section.
- B. Use of Site: Limit use of Project site within project property lines indicated. Do not disturb portions of Project site beyond areas in which the Work is indicated.
 1. Limits: Confine construction operations to within property lines.
 2. Limits: Limit site disturbance, including earthwork and clearing of vegetation, to 40 feet beyond building perimeter; 10 feet beyond surface walkways, patios, surface parking, and utilities less than 12 inches in diameter; 15 feet beyond primary roadway curbs and main utility branch trenches; and 25 feet beyond constructed areas with permeable surfaces (such as pervious paving areas, storm water detention facilities, and playing fields) that require additional staging areas in order to limit compaction in the constructed area.
 3. Driveways, Walkways and Entrances: Keep driveways parking lots, loading areas, and entrances serving premises clear and available to Owner, Owner's employees, and emergency vehicles at all times. Do not use these areas for parking or storage of materials.
 - a. Schedule deliveries to minimize use of driveways and entrances by construction operations.
 - b. Schedule deliveries to minimize space and time requirements for storage of materials and equipment on-site.
- C. Condition of Existing Building: Maintain portions of existing building affected by construction operations in a weathertight condition throughout construction period. Repair damage caused by construction operations.

1.7 WORK RESTRICTIONS

- A. Work Restrictions, General: Comply with restrictions on construction operations.
 - 1. Comply with limitations on use of public streets and other requirements of authorities having jurisdiction.
- B. On-Site Work Hours: Limit work in the existing building to normal business working hours of 7:00 a.m. to 6:00 p.m., Monday through Friday, except as otherwise indicated.
- C. Existing Utility Interruptions: Do not interrupt utilities serving facilities occupied by Owner or others unless permitted under the following conditions and then only after providing temporary utility services according to requirements indicated:
 - 1. Notify Owner not less than 48 hours in advance of proposed utility interruptions.
 - 2. Obtain Owner's written permission before proceeding with utility interruptions.
- D. Noise, Vibration, and Odors: Coordinate operations that may result in high levels of noise and vibration, odors, or other disruption to Owner occupancy with Owner.
 - 1. Notify Owner not less than 72 hours in advance of proposed disruptive operations.
 - 2. Obtain Owner's written permission before proceeding with disruptive operations.
- E. Nonsmoking Building: Smoking is not permitted within the building or within 25 feet of entrances, operable windows, or outdoor air intakes.
- F. Controlled Substances: Use of tobacco products and other controlled substances within the existing building is not permitted.
- G. Employee Identification: Provide identification tags for Contractor personnel working on the Project site. Require personnel to utilize identification tags at all times and when inside the building.
- H. Employee Screening: Comply with Owner's requirements regarding drug and background screening of Contractor personnel working on the Project site.
 - 1. Maintain list of approved screened personnel with Owner's Representative.
- I. Crude or foul language or actions will not be tolerated and will result in Owner asking the General Contractor to remove personnel from the site.
- J. Employee Screening: Provide evidence of COVID-19/temperature screening of all Contractor and Sub-contractor personnel working on the Project site. Notify Owner at once of any positive COVID-19 test cases of site personnel.

1.8 SPECIFICATION AND DRAWING CONVENTIONS

- A. Specification Content: The Specifications use certain conventions for the style of language and the intended meaning of certain terms, words, and phrases when used in particular situations. These conventions are as follows:

1. Imperative mood and streamlined language are generally used in the Specifications. The words "shall," "shall be," or "shall comply with," depending on the context, are implied where a colon (:) is used within a sentence or phrase.
 2. Specification requirements are to be performed by Contractor unless specifically stated otherwise.
- B. Division 01 General Requirements: Requirements of Sections in Division 01 apply to the Work of all Sections in the Specifications.
- C. Drawing Coordination: Requirements for materials and products identified on the Drawings are described in detail in the Specifications. One or more of the following are used on the Drawings to identify materials and products:
1. Terminology: Materials and products are identified by the typical generic terms used in the individual Specifications Sections.
 2. Abbreviations: Materials and products are identified by abbreviations and scheduled on Drawings.
 3. Keynoting: Materials and products are identified by reference keynotes referencing Specification Section numbers found in this Project Manual.

1.9 MISCELLANEOUS PROVISIONS

PART 2 - PRODUCTS (Not Used)

PART 3 - EXECUTION (Not Used)

END OF SECTION 011000

SECTION 023610 - TERMITE CONTROL

PART 1 - GENERAL

1.1 RELATED DOCUMENTS

- A. Drawings and general provisions of the Contract, including General and Supplementary Conditions and Division 1 Specification Sections, apply to this Section.

1.2 SUMMARY

- A. This Section includes the following for termite control:
 - 1. Soil treatment.

1.3 DEFINITIONS

- A. EPA: Environmental Protection Agency.
- B. PCO: Pest control operator.

1.4 SUBMITTALS

- A. Product Data: Treatments and application instructions, including EPA-Registered Label.
- B. Product Certificates: Signed by manufacturers of termite control products certifying that treatments furnished comply with requirements.
- C. Qualification Data: For firms and persons specified in "Quality Assurance" Article to demonstrate their capabilities and experience. Include lists of completed projects with project names and addresses, names and addresses of architects and owners, and other information specified.
- D. Soil Treatment Application Report: After application of termiticide is completed, submit report for Owner's record information, including the following as applicable:
 - 1. Date and time of application.
 - 2. Moisture content of soil before application.
 - 3. Brand name and manufacturer of termiticide.
 - 4. Quantity of undiluted termiticide used.
 - 5. Dilutions, methods, volumes, and rates of application used.
 - 6. Areas of application.

7. Water source for application.

E. Warranties: Special warranties specified in this Section.

1.5 QUALITY ASSURANCE

A. **Applicator Qualifications:** A PCO who is licensed according to regulations of authorities having jurisdiction to apply termite control treatment in jurisdiction where Project is located and who is experienced and has completed termite control treatment similar to that indicated for this Project and whose work has a record of successful in-service performance.

B. **Regulatory Requirements:** Formulate and apply termiticides, and label with a Federal registration number, to comply with EPA regulations and authorities having jurisdiction.

1.6 PROJECT CONDITIONS

A. **Environmental Limitations:** To ensure penetration, do not treat soil that is water saturated or frozen. Do not treat soil while precipitation is occurring. Comply with EPA-Registered Label requirements and requirements of authorities having jurisdiction.

1.7 COORDINATION

A. Coordinate soil treatment application with excavating, filling, and grading and concreting operations. Treat soil under footings, grade beams, and ground-supported slabs, before construction.

1.8 WARRANTY

A. **General Warranty:** Special warranty specified in this Article shall not deprive Owner of other rights Owner may have under other provisions of the Contract Documents and shall be in addition to, and run concurrent with, other warranties made by Contractor under requirements of the Contract Documents.

B. **Special Warranty:** Written warranty, signed by applicator and Contractor certifying that termite control work, consisting of applied soil termiticide treatment, will prevent infestation of subterranean termites. If subterranean termite activity or damage is discovered during warranty period, re-treat soil and repair or replace damage caused by termite infestation.

C. **Warranty Period:** Five years from date of Substantial Completion.

1.9 MAINTENANCE SERVICE

- A. Continuing Service: Provide a proposal for continuing service, including monitoring, inspection, and retreatment for occurrences of termite activity, from applicator to Owner, in the form of a standard yearly (or other period) continuing service agreement, starting on the date of Substantial Completion. State services, obligations, conditions, and terms for agreement period and for future renewal options.

PART 2 - PRODUCTS

2.1 SOIL TREATMENT

- A. Termiticide: Provide an EPA-registered termiticide complying with requirements of authorities having jurisdiction, in a soluble or emulsible, concentrated formulation that dilutes with water or foaming agent, and formulated to prevent termite infestation. Use only soil treatment solutions that are not harmful to plants. Provide quantity required for application at the label volume and rate for the maximum termiticide concentration allowed for each specific use, according to the product's EPA-Registered Label.
- B. Manufacturers: Subject to compliance with requirements, provide products by one of the following:
 - 1. AgrEvo Environmental Health, Inc.; a Company of Hoechst and Schering, Berlin.
 - 2. American Cyanamid Co.; Agricultural Products Group; Specialty Products Department.
 - 3. Bayer Corp.; Garden & Professional Care.
 - 4. DowElanco.
 - 5. FMC Corp.; Pest Control Specialties.
 - 6. Zeneca Professional Products.

PART 3 - EXECUTION

3.1 EXAMINATION

- A. Examine substrates, areas, and conditions, with Applicator present, for compliance with requirements for moisture content of the soil, interfaces with earthwork, slab and foundation work, landscaping, and other conditions affecting performance of termite control. Proceed with application only after unsatisfactory conditions have been corrected.

3.2 PREPARATION

- A. General: Comply with the most stringent requirements of authorities having jurisdiction and with manufacturer's written instructions for preparing substrate. Remove all extraneous sources of wood cellulose and other edible materials such as wood debris, tree stumps and roots, stakes, formwork, and construction waste wood from soil and around foundations.
- B. Soil Treatment Preparation: Remove foreign matter and impermeable soil materials that could decrease treatment effectiveness on areas to be treated. Loosen, rake, and level soil to be treated, except previously compacted areas under slabs and footings. Termiticides may be applied before placing compacted fill under slabs if recommended by termiticide manufacturer.
- C. Fit filling hose connected to water source at the site with a backflow preventer, complying with requirements of authorities having jurisdiction.

3.3 APPLICATION, GENERAL

- A. General: Comply with the most stringent requirements of authorities having jurisdiction and with manufacturer's EPA-Registered Label for products.

3.4 APPLYING SOIL TREATMENT

- A. Application: Mix soil treatment termiticide solution to a uniform consistency. Provide quantity required for application at the label volume and rate for the maximum specified concentration of termiticide, according to manufacturer's EPA-Registered Label, to the following so that a continuous horizontal and vertical termiticidal barrier or treated zone is established around and under building construction. Distribute the treatment evenly.
 - 1. Slabs-on-Grade and Basement Slabs: Under ground-supported slab construction, including footings, building slabs, and attached slabs as an overall treatment. Treat soil materials before concrete footings and slabs are placed.
 - 2. Foundations: Adjacent soil including soil along entire inside perimeter of foundation walls, along both sides of interior partition walls, around plumbing pipes and electric conduit penetrating slab, and around interior column footers, piers, and chimney bases; and along entire outside perimeter, from grade to bottom of footing. Avoid soil washout around footings.
 - 3. Penetrations: At expansion joints, control joints, and areas where slabs will be penetrated.
- B. Avoid disturbance of treated soil after application. Keep off treated areas until completely dry.

- C. Protect termiticide solution, dispersed in treated soils and fills, from being diluted until ground-supported slabs are installed. Use waterproof barrier according to EPA-Registered Label instructions.
- D. Post warning signs in areas of application.
- E. Reapply soil treatment solution to areas disturbed by subsequent excavation, grading, landscaping, or other construction activities following application.

END OF SECTION 02361

SECTION 061600 - SHEATHING

PART 1 - GENERAL

1.1 RELATED DOCUMENTS

- A. Drawings and general provisions of the Contract, including General and Supplementary Conditions and Division 01 Specification Sections, apply to this Section.

1.2 SUMMARY

- A. This Section includes the following:
 - 1. Wall sheathing.
 - 2. Roof sheathing.
 - 3. Building wrap.
 - 4. Sheathing joint-and-penetration treatment.
 - 5. Flexible flashing at openings in sheathing.

1.3 SUBMITTALS

- A. Product Data: For each type of process and factory-fabricated product. Indicate component materials and dimensions and include construction and application details.
 - 1. Include data for wood-preservative treatment from chemical treatment manufacturer and certification by treating plant that treated plywood complies with requirements. Indicate type of preservative used and net amount of preservative retained.
 - 2. For products receiving a waterborne treatment, include statement that moisture content of treated materials was reduced to levels specified before shipment to Project site.
 - 3. Include copies of warranties from chemical treatment manufacturers for each type of treatment.
 - 4. For building wrap, include data on air-/moisture-infiltration protection based on testing according to referenced standards.
- B. Research/Evaluation Reports: For the following, showing compliance with building code in effect for Project:
 - 1. Preservative-treated plywood.
 - 2. Building wrap.

1.4 QUALITY ASSURANCE

- A. Forest Certification: For the following wood products, provide materials produced from wood obtained from forests certified by an FSC-accredited certification body to comply with FSC STD-01-001, "FSC Principles and Criteria for Forest Stewardship":
 - 1. Plywood.

1.5 DELIVERY, STORAGE, AND HANDLING

- A. Stack plywood and other panels flat with spacers between each bundle to provide air circulation. Provide for air circulation around stacks and under coverings.

PART 2 - PRODUCTS

2.1 WOOD PANEL PRODUCTS, GENERAL

- A. Plywood: **DOC PS 1**.
- B. Thickness: As needed to comply with requirements specified, but not less than thickness indicated.
- C. Factory mark panels to indicate compliance with applicable standard.

2.2 PRESERVATIVE-TREATED PLYWOOD

- A. Preservative Treatment by Pressure Process: AWWPA C9.
 - 1. Preservative Chemicals: Acceptable to authorities having jurisdiction **and containing no arsenic or chromium**.
- B. Mark plywood with appropriate classification marking of an inspection agency acceptable to authorities having jurisdiction.
- C. Application: **Treat items indicated on Drawings and plywood in contact with masonry or concrete or used with roofing, flashing, vapor barriers, and waterproofing.**

2.3 ROOF SHEATHING

- A. Plywood Roof Sheathing: **Exterior** sheathing.
 - 1. Span Rating: Not less than **16/0**.
 - 2. Nominal Thickness: Not less than **1/2 inch (13 mm)**.

- B. General: Provide fasteners of size and type indicated that comply with requirements specified in this Article for material and manufacture.
 - 1. For roof **and wall** sheathing, provide fasteners of **Type 304 stainless steel**.
- C. Nails, Brads, and Staples: ASTM F 1667.
- D. Power-Driven Fasteners: NES NER-272.
- E. Wood Screws: ASME B18.6.1.

2.4 WEATHER-RESISTANT BUILDING WRAP

- A. Building Wrap:
 - 1. Products: Subject to compliance with requirements, provide the following:
 - a. Grace Water and Ice Shield
 - 2. Accessories: Provide accessories by manufacturer to insure a complete and proper installation.

2.5 MISCELLANEOUS MATERIALS

- A. Flexible Flashing: Composite, self-adhesive, flashing product consisting of a pliable, rubberized-asphalt compound, bonded to a high-density, cross-laminated polyethylene film to produce an overall thickness of not less than **0.040 inch (1.0 mm)**.
 - 1. Products: Subject to compliance with requirements, provide one of the following:
 - a. Carlisle Coatings & Waterproofing; CCW-705-TWF Thru-Wall Flashing.
 - b. Grace Construction Products, a unit of W. R. Grace & Co. - Conn.; **Vycor Plus Self-Adhered Flashing**.
- B. Primer for Flexible Flashing: Product recommended by manufacturer of flexible flashing for substrate.

PART 3 - EXECUTION

3.1 INSTALLATION, GENERAL

- A. Do not use materials with defects that impair quality of sheathing or pieces that are too small to use with minimum number of joints or optimum joint arrangement.
- B. Cut panels at penetrations, edges, and other obstructions of work; fit tightly against abutting construction, unless otherwise indicated.

- C. Securely attach to substrate by fastening as indicated, complying with the following:
1. NES NER-272 for power-driven fasteners.
 2. Table 2304.9.1, "Fastening Schedule," in ICC's "International Building Code."
 3. Table 23-II-B-1, "Nailing Schedule," and Table 23-II-B-2, "Wood Structural Panel Roof Sheathing Nailing Schedule," in ICBO's "Uniform Building Code."
 4. Table 2305.2, "Fastening Schedule," in BOCA's "BOCA National Building Code."
 5. Table 2306.1, "Fastening Schedule," in SBCCI's "Standard Building Code."
 6. Table R602.3(1), "Fastener Schedule for Structural Members," and Table R602.3(2), "Alternate Attachments," in ICC's "International Residential Code for One- and Two-Family Dwellings."
 7. Table 602.3(1), "Fastener Schedule for Structural Members," and Table 602.3(2), "Alternate Attachments," in ICC's "International One- and Two-Family Dwelling Code."
- D. Use common wire nails, unless otherwise indicated. Select fasteners of size that will not fully penetrate members where opposite side will be exposed to view or will receive finish materials. Make tight connections. Install fasteners without splitting wood.
- E. Coordinate **wall and roof** sheathing installation with flashing and joint-sealant installation so these materials are installed in sequence and manner that prevent exterior moisture from passing through completed assembly.
- F. Do not bridge building expansion joints; cut and space edges of panels to match spacing of structural support elements.
- G. Coordinate sheathing installation with installation of materials installed over sheathing so sheathing is not exposed to precipitation or left exposed at end of the workday when rain is forecast.

3.2 WOOD STRUCTURAL PANEL INSTALLATION

- A. General: Comply with applicable recommendations in APA Form No. E30S, "Engineered Wood Construction Guide," for types of structural-use panels and applications indicated.
- B. Fastening Methods: Fasten panels as indicated below:
1. Combination Subfloor-Underlayment:
 - a. **Nail** to wood framing.
 - b. Space panels 1/8 inch (3 mm) apart at edges and ends.
 2. Subflooring:
 - a. **Nail** to wood framing.

- b. Space panels 1/8 inch (3 mm) apart at edges and ends.
- 3. Wall and Roof Sheathing:
 - a. **Nail** to wood framing.
 - b. Space panels 1/8 inch (3 mm) apart at edges and ends.

3.3 FLEXIBLE FLASHING INSTALLATION

- A. Apply flexible flashing where indicated to comply with manufacturers written instructions.
 - 1. Prime substrates as recommended by flashing manufacturer.
 - 2. Lap seams and junctures with other materials at least 4 inches (100 mm), except that at flashing flanges of other construction, laps need not exceed flange width.
 - 3. Lap flashing over weather-resistant building paper at bottom and sides of openings.
 - 4. Lap weather-resistant building paper over flashing at heads of openings.
 - 5. After flashing has been applied, roll surfaces with a hard rubber or metal roller to ensure that flashing is completely adhered to substrates.

END OF SECTION 061600

SECTION 07 41 13
Metal Roof Panels
Maxima

Part 1 GENERAL

1.1 SUMMARY

- A. Section Includes: Factory-formed sheet metal roofing, including flashings and trim.
- B. Related Sections: Section(s) related to this section include:
 - 1. Cold Formed Metal Framing: Division Metal Framing Section.
 - 2. Sealants: Division 7 Joint Sealants Section.
 - 3. 076200 Sheet Metal Flashing

1.2 REFERENCES

- A. American Society for Testing and Materials (ASTM):
 - 1. ASTM A653/A653M Standard Specification for Steel Sheets, Zinc-Coated (Galvanized) or Zinc-Iron Alloy-Coated (Galvannealed) by the Hot-Dip Process.
 - 2. ASTM A792/A792M Standard Specification for Steel Sheet, 55% Aluminum-Zinc Alloy Coated by the Hot Dip Process.
 - 3. ASTM B209 Standard Specification for Aluminum and Aluminum-Alloy Sheet and Plate.
 - 4. ASTM D2247 Standard Practice for Testing Water Resistance of Coatings in 100% Relative Humidity.
 - 5. ASTM E1680 Standard Test Method for Determining the Rate of Air Leakage Through Exterior Windows, Curtain Walls and Doors Under Specified Pressure Differences Across the Specimen.
 - 6. ASTM E1646 Standard Test Method for Water Penetration of Exterior Windows, Curtain Walls and Doors by Uniform Static Air Pressure Difference.
 - 7. ASTM G90 Standard Practice for Performing Accelerated Outdoor Weathering of Non-Metallic Materials Using Concentrated Natural Sunlight.
 - 8. ASTM D 2244 - Standard Practice for Calculation of Color Tolerances and Color Differences from Instrumentally Measured Color Coordinates.
 - 9. ASTM D 4214 - Standard Test Methods for Evaluating the Degree of Chalking of Exterior Paint Films
 - 10. ASTM E 119 - Standard Test Methods for Fire Tests of Building Construction and Materials
 - 11. ASTM E 1592 - Standard Test Method for Structural Performance of Sheet Metal Roof and Siding Systems by Uniform Static Air Pressure Difference.

12. ASTM E 2140 - Standard Test Method for Water Penetration of Metal Roof Panel Systems by Static Water Pressure Head.

- B. Underwriters Laboratories (UL):
 - 1. UL 263 - Fire Tests of Building Construction and Materials.
 - 2. 580 - Tests for Uplift Resistance of Roof Assemblies.
 - 3. UL 790 - Standard Test Methods for Fire Tests of Roof Coverings.
- 4. UL 2218 - Impact Resistance of Prepared Roof Covering Materials.

- C. Sheet Metal and Air Conditioning Contractors' National Association (SMACNA);
"Architectural Sheet Metal Manual"

- D. Miami-Dade County

- E. Florida Building Code

- F. Texas Windstorm Approval

1.3 ADMINISTRATIVE REQUIREMENTS

A. Pre-installation Meetings:

- 1. Schedule meeting to discuss roof project requirements, substrate conditions, manufacturer's installation instructions and manufacturer's warranty requirements before start of work onsite. Comply with Division 1 Project Management and Coordination (Project Meetings) Section.

Dates to be scheduled after award of bid.

- 2. Required attendees: Contractor, metal deck & roof installer, and any other subcontractors who have equipment penetrating the roof or work that requires roof access or traffic.

1.4 SYSTEM DESCRIPTION

A. Performance Requirements: Provide sheet metal roofing which has been manufactured, fabricated and installed to withstand structural and thermal movement, wind loading and weather exposure to maintain manufacturer's performance criteria without defects, damage, failure or infiltration of water.

- 1. Air infiltration: Maximum 0.06 cfm per lineal foot (0.33 m³/hr per linear meter) of seam at static pressure of 6.24 psf (3.0 kPa) when tested per ASTM E1680.

2. Water penetration:
 - a. No uncontrolled water penetration through the joints at a static pressure of 6.24 psf (3.0 kPa) when tested in accordance with ASTM E1646.
3. Fire rating: Class A
4. Uplift Tests:
 - a. UL 580 Class 90
 - b. FM 4471 (2" only I-90)
 - c. ASTM E 1592 (1.5", 2" & 3")
5. Miami Dade: 2" x 16" only
6. Class 4 Impact Resistance: UL 2218
7. Fire Resistance: UL 263
8. Florida State Approval
9. ICC-ES: ESL 1082

Specifier Note: Delete paragraph below if only bare or mill finishes are required.

B. Finish Performance Requirements:

1. Two coat coil applied, baked on full strength (70% resin, PVF2) fluorocarbon coating consisting of a nominal 0.25 mil dry film thickness primer, and a nominal dry film thickness of 0.7 -0.8 mil color coat for a total 0.9 to 1.1 mil total system dry film thickness.
2. Color change and fade resistance: No cracking, peeling, blistering or loss of adhesion when tested in accordance with ASTM G23; color change, after removal of surface deposits such as dirt or chalk, maximum 5 NBS units.
3. Humidity resistance: No blistering, peeling or loss of adhesion after 1000 hours testing, in accordance with ASTM D2247.

1.5 SUBMITTALS

- A. General: Submit listed submittals in accordance with Conditions of the Contract and Division 1 Submittal Procedures Section.
- B. Product Data: Submit manufacturer's product data for specified products.
- C. Shop Drawings: Submit shop drawings showing layout, profiles and product components, including anchorage, accessories, finish colors and textures.
 1. Indicate layout of roofing panels and roof panel sizes, including custom-fabricated roofing panels if indicated; indicate each item of trim and accessories.
 2. Indicate in detailed drawings profile and gauge of interior and exterior sheets, and locations and types of fasteners; indicate locations, gauges, shapes and methods of attachment of roofing panels, trim and accessory items.

3. Include Sealant location and denote those that are factory and field applied.
4. Indicate products/materials required for construction activities and field worked conditions of this section not supplied by manufacturer of products of this section.

E. Samples: Submit selection and verification samples for finishes, colors and textures.

1. Selection Samples: For each product requiring color selection, 2 sets of manufacturer's sample chips representing full range of colors and finishes available.
2. Verification Samples: For each color and finish selected, 2 chips indicating match to selected color and finish.

F. Warranties:

1. Substrate Warranty
2. Finish Warranty
3. Weather Tightness Warranty (if applicable)

G. Test and Evaluation Reports: Showing compliance with specified performance characteristics and physical properties.

H. Quality Assurance Submittals: Submit the following:

1. Contractor Certificates: Contractor's certification that:
 - a. Manufacturer of products of this section meets specified qualifications.
 - b. Installer of products of this section meets specified qualifications.
2. Manufacturer Certificates: Product certificates signed by manufacturer certifying materials comply with specified performance characteristics and physical requirements.
3. Manufacturer's Instructions: Manufacturer's installation instructions.
4. Manufacturer's Field Reports: Manufacturer's field reports if required.

I. Closeout Submittals: Submit the following:

1. Warranty: Warranty documents specified herein.

J. Buy American Certification: Manufacturer's letters of compliance indicating supplied products comply with requirements.

1.6 QUALITY ASSURANCE

A. Manufacturer Qualifications:

1. Provider of "hands on" installer training at manufacturer or customer facility.

2. Minimum of ten years' experience in manufacturing metal roof systems.
3. Provider of product produced in a permanent factory environment with fixed roll-forming equipment and also possesses the capability to roll form continuous panels on jobsites with a factory technician for jobs with panel lengths in excess of 50'

B. Installer Qualifications:

1. At least five years' experience in the installation of structural standing seam metal roof panels.
2. Experience on at least five projects of similar size, type and complexity as this project that have been in service for a minimum of two years with satisfactory performance of the roof system.
3. Employer of workers for this project who are competent in techniques required by manufacturer for installation indicated and who shall be supervised at all times when material is being installed.
4. Certificate: When requested, submit certificate indicating qualification.

C. Mock-Ups: Establish standards by which work will be judged. Coordinate below with Division 1 Quality Control (Mock-up Requirements) Section. Mock-Ups: Install at project site a job mock-up using acceptable products and manufacturer approved installation methods. Obtain Owner's and Architect's acceptance of finish color, texture and pattern and workmanship standard. Comply with Division 1 Quality Control (Mock-Up Requirements) Section.

1. Include eave, ridge, valley, gable and hip conditions.
2. Mock-Up Size: [Specify size.].
3. Maintenance: Maintain mock-up during construction for workmanship comparison; remove and legally dispose of mock-up when no longer required.
4. Incorporation: Mock-up may be incorporated into final construction upon Owner's approval.

A. D. Buy American Compliance: Materials provided under Work of this Section shall comply with the following requirements:

1. Buy American Act of 1933 BAA-41 U.S.C §§ 10a – 10d.
2. Buy American provisions of Section 1605 of the American Recovery and Reinvestment Act of 2009 (ARRA).

1.7 DELIVERY, STORAGE & HANDLING

A. General: Comply with Division 1 Product Requirements Sections.

1. Ordering: Comply with manufacturer’s ordering instructions and lead time requirements to avoid construction delays.
- B. Delivery: Deliver materials in manufacturer’s original, unopened, undamaged containers with identification labels intact. Identify fabricated components with UL 90 label where appropriate.
- C. Delivery and Acceptance Requirements: Ensure all panels are received in good condition. In cases where damage is visible, note all paperwork; inform architect and project superintendent.
- D. Packing, Shipping, Handling and Unloading:
 1. Roofing panels to be crated to protect panels from shipping damage.
 2. Package trim and accessories in waterproof wrapping paper.
- E. Storage and Protection: Store materials protected from exposure to harmful conditions. Store material in dry, above-ground location.
 1. Stack prefinished material to prevent twisting, bending, abrasion, scratching and denting. Elevate one end of each skid to allow for moisture runoff.
 2. Store products of this section in manufacturer’s unopened packaging until installation of products
 3. Maintain dry, heated storage area for products of this section until installation of products.
 4. Remove strippable plastic film before storage under high-heat conditions.

1.8 PROJECT CONDITIONS

- A. Field Measurements: Verify actual measurements/openings by field measurements before fabrication; show recorded measurements on shop drawings. Coordinate field measurements, fabrication schedule with construction progress to avoid construction delays.
- B. Weather Limitations: Proceed with installation only when existing and forecasted weather conditions permit assembly of metal panels to be performed in accordance with manufacturers’ written instructions and warranty requirements.

1.9 WARRANTY

- A. Project Warranty: Refer to Conditions of the Contract for project warranty provisions.
 1. Panel Material: Furnish manufacturers 25 year warranty covering the panel against rupture, structural failure, or perforation.
 2. Panel Coating: Furnish manufacturer's 40-year warranty covering cracking, checking, and peeling, and 30 year warranty covering fade and chalk on the

Two coat coil applied, baked on full strength (70% resin, PVF2) fluorocarbon coating.

- a. Manufacturer's warranty may exclude surface deterioration due to physical damage and corrosive environments.

B. Weather Tightness Warranty

1. Weathertightness Warranty: Manufacturers [Joint][Single Source] weather-tightness warranty.
2. Warranty Term: [5][10][15][20][25] commencing on Date of Substantial Completion.
3. Total Manufacturers Liability: [\$0.20 (Joint Only)] [\$7.00] [\$14.00][NRL (No Repair Limit)] /sq. ft.
4. Warranty must cover (choose all that apply) [pipe and curb penetrations][winds up to [75] [80] [90] [100] [105] [110] [120] mph
 - a. (If Penetrations are chosen) Pipes must be centered in the panel or a pipe curb must be used, Curbs must be all welded (0.0630 minimum) aluminum or 18ga. Stainless Steel.
 - b. (If Wind Rider is chosen) Manufacturer must supply engineered installation shop drawings, signed and sealed by an Engineer registered in the state in which the project is located.

- C. Special Warranty: Installer's standard form in which installer agrees to repair or replace panels that fail due to poor workmanship or faulty installation within the specified warranty period.

1. Warranty Period: <Insert number of years> years from date of Substantial Completion.

PART 2 PRODUCTS

2.1 Metal Roof Panels

- A. Manufacturer: McElroy Metal, Inc.

1. Contact: 1500 Hamilton Rd., Bossier City, LA 71111; Telephone: (800) 950-6531; Fax: (318) 747-8099; E-mail: info@mcelroymetal.com; website: www.mcelroymetal.com.
2. Proprietary Products: McElroy Metal Preformed Sheet Metal Roofing Panels.

- B. Substitutions:

1. Basis of Design Product: Subject to compliance with requirements provide McElroy Metal Maxima 1.5. No substitutions for higher seam
2. Substitution Limitations

- a. Requests for approval must be submitted in writing at least ten (10) days prior to bid date, and are accompanied by all related test reports and design calculations listed in section 1.4 and Design and Performance criteria Section 2.2.
- b. Substitute manufacturers will be approved by written addendum to all bidders. Voluntary alternates will not be considered. Substitutions will not be permitted after the bid date of this project.
- c. Roof panels proposed for substitution shall fully comply with specified requirements in appearance, assembly, and performance.

C. Forming: Use continuous end rolling method. No end laps are permitted on panels without architect approval. It is the intent of the Architect to provide factory-manufactured panel systems or systems manufactured on-site by factory personnel only for this project.

2.2 MANUFACTURED UNITS

A. McElroy Metal Maxima Panels:

1. Profile: Vertical leg standing seam panel with male/female seam to be mechanically interlocked at jobsite with mechanical seamer specifically designed for Maxima profile.
2. Size: 1.5” high seam by 12” width (51 x 406 mm). Length as indicated on drawings. No substitution for higher seam.
3. Panel Surface: 1.5”: Flat pan
4. Material: Galvalume steel sheet conforming to ASTM A792, AZ50 coating for bare; AZ50 coating for painted; 22gauge sheet thickness.
5. Panels should be factory formed for lengths below 50’. To avoid lap conditions for panels greater than 50’, panels should be produced on site but production must be completed by factory technicians.

2.3 METAL ROOF PANEL ACCESSORIES

General: Provide complete metal roof panel assembly incorporating trim, copings, fasciae, gutters and downspouts, and miscellaneous flashings, in [manufacturer's standard profiles] [profiles as indicated]. Provide required fasteners, closure strips, splice plates, support plates, and sealants as indicated in manufacturer's written instructions.

- A. Flashing and Trim: Match material, thickness, and finish of metal panel face sheet.
- B. Panel Clips: ASTM A 653/A 653M, G90 (Z180) hot-dip galvanized zinc coating, configured for concealment in panel joints, and identical to clips utilized in tests demonstrating compliance with performance requirements.

- C. Panel Fasteners: Self-tapping screws and other acceptable corrosion-resistant fasteners recommended by roof panel manufacturer. Where exposed fasteners cannot be avoided, supply fasteners with EPDM or neoprene gaskets, with heads matching color of metal panels by means of factory-applied coating.
- D. Joint Sealers: Manufacturer's standard or recommended liquid and preformed sealers and tapes, and as follows:
 - 1. Factory-Applied Seam Sealant: Manufacturer's standard hot-melt type.
 - 2. Tape Sealers: Manufacturer's standard non-curing butyl tape, AAMA 809.2.
 - 3. Concealed Joint Sealant: Non-curing butyl, AAMA 809.2.
- E. Steel Sheet Miscellaneous Framing Components: ASTM C 645, with ASTM A 653/A 653M, G60 (Z180) hot-dip galvanized zinc coating.
- F. Roof Accessories: Approved by metal roof panel manufacturer. Refer to [Section 07 72 00] "Roof Accessories" for requirements for roof accessories.
- G. Snow Guards: Approved by metal roof panel manufacturer. Refer to [Section 07 72 53] "Snow Guards" for requirements for snow guards attached to metal roof panels

2.4 FABRICATION

- A. General: Provide factory fabricated and finished metal panels and accessories meeting performance requirements, indicated profiles, and structural requirements.
- B. Fabricate metal panel joints configured to accept factory-applied sealant providing weathertight seal and preventing metal-to-metal contact and minimizing noise resulting from thermal movement.
- C. Form panels in continuous lengths for full length of detailed runs, except where otherwise indicated on approved shop drawings.
- D. Sheet Metal Flashing and Trim: Fabricate flashing and trim to comply with manufacturer's written instructions, approved shop drawings, and project drawings. Form from materials matching metal panel substrate.

2.5 FINISHES

- A. Two coat coil applied, baked on full strength (70% resin, PVF2) fluorocarbon coating consisting of a nominal 0.25 mil dry film thickness primer, and a nominal dry film thickness of 0.7 -0.8 mil color coat for a total 0.9 to 1.1 mil total system dry film thickness. Finish to be selected from manufacturer's standard color selection. The back side of the material should be 0.25 mil primer and a 0.25 mil polyester wash coat.

1. Roof Panel Color:
 - a. Selected from full range of manufacturer’s standard colors.
 - b. Color: Provide Standard Color samples for owner selection
 - c. Color: TBD
 2. Roof Related Trim/Accessories Color:
 - d. Selected from full range of manufacturer’s standard colors.
 - e. Color: Provide Standard Color samples for owner selection
 - f. Color: TBD
- B. Bare Galvalume steel sheet conforming to ASTM A792, AZ55

2.6 RELATED MATERIALS

2.7 SOURCE QUALITY

- A. Source Quality: Obtain metal panel products from a single manufacturer.
- B. Quality Control: Obtain structural standing seam metal roof panels, trim and other accessories from a manufacturer capable of providing on-site technical support and installation assistance.

PART 3 EXECUTION

3.1 MANUFACTURER’S INSTRUCTIONS

- A. Compliance: Comply with manufacturer’s product data, recommendations and installation instructions for substrate verification, preparation requirements and installation.
 1. Strippable Film: Remove manufacturer’s protective film, if any, from surfaces of roofing panels.
- B. Site Verification of Conditions: Verify substrate conditions, which have been previously installed under other sections, are acceptable for product installation in accordance with manufacturer’s instructions.
 1. Verification of Conditions:
 - a. Panel support systems are ready for construction activities of this section and within specified tolerances.
 - b. Rough-in utilities are in correct locations.
 2. Installer’s Examination:

- a. Have installer of this section examine conditions under which construction activities of this section are to be performed, then submit written notification if such conditions are unacceptable.
- b. Transmit 2 copies of installer's report to Architect within 24 hours of receipt.
- c. Delay construction activities of this section until unacceptable conditions have been corrected.
- d. Beginning construction activities of this section indicates installer's acceptance of conditions.

3.2 PREPARATION

- A. Coordination: Coordinate metal roofing with other work to provide a noncorrosive and leak-proof installation.
 1. Install substrate boards, hat channels, purlins, or furring channels in accordance with manufacturer's recommendations.
 2. Coordinate work, with installation of other associated Work, to ensure quality application.
 3. Coordinate work with installation of associated metal flashings and building walls.
 4. Coordinate work to minimize foot traffic and construction activity on installed finished surfaces.
 5. Coordinate location of pipe penetrations to allow centering of pipe in panel.
 6. Coordinate location of roof curbs, to allow proper integration with roof panel.
 7. Coordinate work to minimize foot traffic and construction activity on installed finished. surfaces.
 8. Dissimilar Metals: Prevent galvanic action of dissimilar metals.

3.3 INSTALLATION

- A. General: Install metal roofing panels to profiles, patterns and drainage indicated and required for leak-proof installation. Provide for structural and thermal movement of work. Seal joints for leak-proof installation.
 1. Shim or otherwise plumb substrates receiving metal panels.
 2. Flash and seal metal panels at perimeter of all openings. Fasten with self-tapping screws.
 3. Do not begin installation until air- or water-resistive barriers and flashings that will be concealed by metal panels are installed.
 4. Install screw fasteners in predrilled holes for clip installation.
 5. Locate and space fasteners in uniform vertical and horizontal alignment.
 6. Install flashing and trim as metal panel work proceeds.
 7. Install continuous length panels if at all possible. If splices are required, locate panel splices over, but not attached to, structural supports.

8. Align bottoms of metal panels and fasten with blind rivets, bolts, or self-tapping screws.
9. Fasten flashings and trim around openings and similar elements with self-tapping screws.
10. Provide weathertight EPDM Flashing for pipe- and conduit-penetrating panels.
11. Seams: Provide uniform, neat seams.
12. Fix panels at location depicted on reviewed shop drawings.
13. Allow for required panel clearance at penetrations for thermal movement.
14. Align pipe penetrations to occur at center of roof panel. Report and have corrected improperly placed penetrations before proceeding with panel installation. Remove and replace roof panels which have improperly placed penetration flashings.
15. Allow for required panel clearance at penetrations for thermal movement.
16. Fasteners: Conceal fasteners where possible in exposed work. Cover and seal fasteners and anchors for watertight and leak-proof installation.
17. Sealant-Type Joints: Provide sealant-type joint where indicated. Form joints to conceal sealant. Comply with Division 7 Joint Sealants Section for sealant installation.

B. Roofing Installation:

1. Install roofing plumb, true and in correct alignment with structural framing, in accordance with shop drawings and manufacturer's printed installation instructions.
2. Install roofing using manufacturer's concealed fastening system or non-corroding fasteners color-matched to panel.
3. Install trim using concealed fasteners where possible; sight-exposed non-corroding fasteners color-matched to trim are permitted on vertical surfaces only.

C. Installation Tolerances:

1. Variation from Plumb: Maximum 1/8" (3.2 mm) in 20 feet (6.096 m).
2. Variation from Level: Maximum 1/8" (3.2 mm) in 20 feet (6.096 m).
3. Variation from True Plane: Maximum 1/4" (3.2 mm) in 20 feet (6.096 m).

D. Underlayment Installation

1. Underlayment to be supplied by metal roof panel manufacturer.
2. Self-adhered High-Temperature Underlayment: Provide self-adhering, cold-applied, sheet underlayment, a minimum of 40 mils thick adhesive, with release-paper backing. Provide primer when recommended by underlayment manufacturer.
3. Thermal Stability: Stable after testing at 240 degree F; ASTM D1970.
4. Low-Temperature Flexibility: Passes after testing at minus 20 degree F; ASTM D1970.

5. Supplied by metal roof panel manufacturer.
- E. Accessory Installation: Install accessories using techniques recommended by manufacturer and which will assure positive anchorage to building and weathertight mounting. Provide for thermal movement. Coordinate installation with flashings and other components
- F. Flashing and Trim Installation: Comply with performance requirements, manufacturer's written installation instructions, and the SMACNA "Architectural Sheet Metal Manual." Provide concealed fasteners where possible, and install units to true level. Install work with laps, joints, and seams that will be permanently watertight.

3.4 FIELD QUALITY REQUIREMENTS

- A. Site Tests: (Post-Installation Testing): Owner reserves right to perform post-installation testing of installed metal panel installation.
- B. Manufacturer's Field Services: Upon Owner's request, provide manufacturer's field service consisting of product use recommendations and periodic site visit for inspection of product installation in accordance with manufacturer's instructions.

3.5 CLEANING

- A. Cleaning: Remove temporary coverings and protection of adjacent work areas.
- B. Repair or replace damaged installed products.
- C. Clean installed products in accordance with manufacturer's instructions prior to Owner's acceptance.
- D. Remove construction debris from project site and legally dispose of debris.
- E. Remove strippable coating and perform dry wipe-down cleaning of panels as erected.

3.6 PROTECTION

- A. Protection: Protect installed product's finish surfaces from damage during construction:
 1. Protect installed products from damage by subsequent construction activities.
 2. Replace products having damage other than minor finish damage.
 3. Repair products having minor damage to finish in accordance with panel Manufacturer's recommendation

4. Architect shall be sole judge of acceptability of repair to damaged finishes;
replace products having rejected repairs

3.7 SCHEDULES

- A. Schedules: Refer to panel schedule attached to this section.

END OF SECTION

SECTION 074610 – CEMENT SIDING

PART 1 GENERAL

1.1 SECTION INCLUDES

- A. Fiber cement lap siding, panels, shingle, trim, fascia, moulding and accessories; James Hardie HZ5 Engineered for Climate Siding.

1.2 RELATED SECTIONS

- A. Section 06100 - Rough Carpentry: Wood framing and bracing.
- B. Section 06100 - Rough Carpentry: Sheathing.

1.3 REFERENCES

- A. ASTM C1186 - Standard Specification for Flat Fiber-Cement Sheets
- B. ASTM D3359 - Standard Test Method for Measuring Adhesion by Tape Test, Tool and Tape.
- C. ASTM E136 - Standard Test Method for Behavior of Materials in a Vertical Tube Furnace at 750 degrees C.

1.4 SUBMITTALS

- A. Submit under provisions of Section 01300.
- B. Product Data: Manufacturer's data sheets on each product to be used, including:
 - 1. Preparation instructions and recommendations.
 - 2. Storage and handling requirements and recommendations.
 - 3. Installation methods.
- C. Shop Drawings: Provide detailed drawings of atypical non-standard applications of cementitious siding materials which are outside the scope of the standard details and specifications provided by the manufacturer.
- D. Selection Samples: For each finish product specified, two complete sets of color chips representing manufacturer's full range of available colors and patterns.
- E. Verification Samples: For each finish product specified, two samples, minimum size 4 by 6 inches (100 by 150 mm), representing actual product, color, and patterns.

1.5 QUALITY ASSURANCE

- A. Installer Qualifications: Minimum of 2 years experience with installation of similar products.
- B. Mock-Up: Provide a mock-up for evaluation of surface preparation techniques and application workmanship.
 - 1. Finish areas designated by Architect.
 - 2. Do not proceed with remaining work until workmanship, color, and sheen are approved by Architect.
 - 3. Refinish mock-up area as required to produce acceptable work.

1.6 DELIVERY, STORAGE, AND HANDLING

- A. Store products in manufacturer's unopened packaging until ready for installation.
- B. Store siding on edge or lay flat on a smooth level surface. Protect edges and corners from chipping. Store sheets under cover and keep dry prior to installing.
- C. Store and dispose of solvent-based materials, and materials used with solvent-based materials, in accordance with requirements of local authorities having jurisdiction.

1.7 PROJECT CONDITIONS

- A. Maintain environmental conditions (temperature, humidity, and ventilation) within limits recommended by manufacturer for optimum results. Do not install products under environmental conditions outside manufacturer's absolute limits.

1.8 WARRANTY

- A. Product Warranty: Limited, non-pro-rated product warranty.
 - 1. HardiePlank HZ5 lap siding for 30 years.
 - 2. HardiPanel HZ5 vertical siding for 30 years.
 - 3. HardieSoffit HZ5 panels for 30 years.
 - 4. HardieShingle HZ5 siding for 30 years.
- B. Product Warranty: Limited, product warranty.
 - 1. HardieTrim HZ and HZ5 boards for 15 years.
- C. Workmanship Warranty: Application limited warranty for 2 years.

PART 2 PRODUCTS

2.1 MANUFACTURERS

- A. Acceptable Manufacturer: James Hardie Building Products, Inc., which is located at: 26300 La Alameda Suite 400 ; Mission Viejo, CA 92691; Toll Free Tel: 866-274-3464; Tel: 949-367-4980; Fax: 949-367-4981; Email: [request info \(info@jameshardie.com\)](mailto:info@jameshardie.com); Web: www.jameshardiecommercial.com
- B. Substitutions: Not permitted.
- C. Requests for approval of equal substitutions will be considered in accordance with provisions of Section 01600.

2.2 SIDING

- A. Lap Siding: Lap Siding as manufactured by James Hardie Building Products, Inc.
 - 1. Type: Smooth 9-1/4 inches (184 mm) with 8 inches (152 mm) exposure.
- B. Vertical Siding: Vertical siding as manufactured by James Hardie Building Products, Inc.
 - 1. Type: Smooth Vertical siding panel 4 feet by 8 feet (1219 mm by 2438 mm).
- C. Trim:
 - 1. HardieTrim HZ5 boards and HardieTrim HZ boards as manufactured by James Hardie Building Products, Inc.
 - 2. HardieTrim HZ5 Fascia boards as manufactured by James Hardie Building Products, Inc.

2.3 FASTENERS

- A. Wood Framing Fasteners:
 - 1. Wood Framing: Stainless Steel nails.

2.4 FINISHES

- A. Factory Primer: Provide factory applied universal primer.
 - 1. Primer: Factory primed by James Hardie.
 - 2. Topcoat: Refer to Specification Section 099113.

PART 3 EXECUTION

3.1 EXAMINATION

- A. Do not begin installation until substrates have been properly prepared.
- B. If framing preparation is the responsibility of another installer, notify Architect of unsatisfactory preparation before proceeding.
- C. Nominal 2 inch by 4 inch (51 mm by 102 mm) wood framing selected for minimal shrinkage and complying with local building codes, including the use of water-resistive barriers or vapor barriers where required. Minimum 1-1/2 inches (38 mm) face and straight, true, of uniform dimensions and properly aligned.
 - 1. Install water-resistive barriers and claddings to dry surfaces.
 - 2. Repair any punctures or tears in the water-resistive barrier prior to the installation of the siding.
 - 3. Protect siding from other trades.

3.2 PREPARATION

- A. Clean surfaces thoroughly prior to installation.
- B. Prepare surfaces using the methods recommended by the manufacturer for achieving the best result for the substrate under the project conditions.
- C. Install a water-resistive barrier is required in accordance with local building code requirements.
- D. The water-resistive barrier must be appropriately installed with penetration and junction flashing in accordance with local building code requirements.

3.3 INSTALLATION - HARDIEPLANK HZ5 LAP SIDING

- A. Install materials in strict accordance with manufacturer's installation instructions.
- B. Starting: Install a minimum 1/4 inch (6 mm) thick lath starter strip at the bottom course of the wall. Apply planks horizontally with minimum 1-1/4 inches (32 mm) wide laps at the top. The bottom edge of the first plank overlaps the starter strip.
- C. Allow minimum vertical clearance between the edge of siding and any other material in strict accordance with the manufacturer's installation instructions.
- D. Align vertical joints of the planks over framing members.
- E. Maintain clearance between siding and adjacent finished grade.

- F. Locate splices at least one stud cavity away from window and door openings.
- G. Wind Resistance: Where a specified level of wind resistance is required Hardieplank lap siding is installed to framing members and secured with fasteners described in Table No. 2 in National Evaluation Service Report No. NER-405.
- H. Locate splices at least 12 inches (305 mm) away from window and door openings.

3.4 INSTALLATION - HARDIEPANEL HZ5 VERTICAL SIDING

- A. Install materials in strict accordance with manufacturer's installation instructions.
- B. Block framing between studs where HardiePanel siding horizontal joints occur.
- C. Install metal Z flashing and provide a 1/4 inch (6 mm) gap at horizontal panel joints.
- D. Place fasteners no closer than 3/8 inch (9.5 mm) from panel edges and 2 inches (51 mm) from panel corners.
- E. Allow minimum vertical clearance between the edge of siding and any other material in strict accordance with the manufacturer's installation instructions.
- F. Maintain clearance between siding and adjacent finished grade.
- G. Specific framing and fastener requirements refer to Tables 2 and 3 in National Evaluation Service Report No. NER-405.

3.5 INSTALLATION - HARDIETRIM HZ5 BOARDS

- A. Install materials in strict accordance with manufacturer's installation instructions. Install flashing around all wall openings.
- B. Fasten through trim into structural framing or code complying sheathing. Fasteners must penetrate minimum 3/4 inch (19 mm) or full thickness of sheathing. Additional fasteners may be required to ensure adequate security.
- C. Place fasteners no closer than 3/4 inch (19 mm) and no further than 2 inches (51 mm) from side edge of trim board and no closer than 1 inch (25 mm) from end. Fasten maximum 16 inches (406 mm) on center.
- D. Maintain clearance between trim and adjacent finished grade.
- E. Trim inside corner with a single board trim both side of corner.
- F. Outside Corner Board Attach Trim on both sides of corner with 16 gage corrosion resistant finish nail 1/2 inch (13 mm) from edge spaced 16 inches

(406 mm) apart, weather cut each end spaced minimum 12 inches (305 mm) apart.

- G. Allow 1/8 inch gap between trim and siding.
- H. Seal gap with high quality, paint-able caulk.
- I. Shim frieze board as required to align with corner trim..
- J. Fasten through overlapping boards. Do not nail between lap joints.
- K. Overlay siding with single board of outside corner board then align second corner board to outside edge of first corner board. Do not fasten HardieTrim boards to HardieTrim boards.
- L. Shim frieze board as required to align with corner trim.
- M. Install HardieTrim Fascia boards to rafter tails or to sub fascia.

3.6 PROTECTION

- A. Protect installed products until completion of project.
- B. Touch-up, repair or replace damaged products before Substantial Completion.

END OF SECTION

099000 - GENERAL FINISHES



City of Tybee Island,
Renovations to Memorial Park Pavilion

issued: 09/04/2020

FINISH SELECTIONS :

NOTES:

CONCRETE FLOOR	Epoxy Coating- SlipDoctors Dura Grip or equal	Color contingent upon owner approval
LOWER COLUMNS, STORAGE SHED	Benjamin Moore- Lafayette Green, HC135	Color contingent upon owner approval
CEILING, UPPER PORTION OF COLUMNS	Benjamin Moore - Acadia White, AC41	Color contingent upon owner approval
ROOFING	See Specs,	
LIGHTING	See attached	



Dura Grip

Technical Data Sheet

Product Description - Dura Grip is an epoxy coating specifically designed to provide a hard, durable barefoot-friendly textured surface on a variety of substrates. It is ideal for use on diamond-plate metal ramps, boat decks, trailers, stairs, locker rooms, laundry rooms and other residential and industrial areas where anti-slip protection is desired. Dura Grip is available in three sizes and an assortment of colors to meet your needs.

SlipDoctors Dura Grip

Special Features

- Interior and Exterior Use
- Increases Traction
- Semi-gloss Finish
- Easy to apply
- Barefoot Friendly
- Paw Friendly
- Chemical Resistant
- Custom Colors Available

Suggested Uses

- Commercial and Residential Use
- Restrooms
- Locker Rooms
- Trailers, Loading Docks
- Steps & Stairs
- Ramps
- Boat Decks
- Diamond Plate Metal

Product Characteristics and Benefits

Surfaces*	Steel, fiberglass, aluminum, concrete, wood, tiles & natural stone
Color	Black, clear, dark brown, light gray, medium gray, safety blue, safety yellow, safety red, sand and white
Mode of Application	3/8" Nap roller
Container Size	Quart, gallon, 5-gallon pails
Application Temperature	Surface temp is between 50-90°F (10-32°C); must be > 5°F (-15°C) above the dew point
Dry Time	Light Traffic 12-24 hours Normal Traffic 24 hours
Recoat Time	2-4 hours
Water Resistant	Yes; cannot be continuously submerged
Stain Resistant	Yes
Product Type	Solvent-based epoxy coating
Coverage	300 sq.ft./gallon, coverage will vary due to surface porosity
Storage	Room temperature in a well area; Do not freeze
Shelf Life	2 years unopened, 1 year if opened
Warranty	2 years
Removal	Paint Stripper
Disposal	Dispose of container and unused contents in accordance with local, state and federal regulations.

Item #10.

* Not intended for constant hot tire traffic.

- Page 155 -

Directions for Preparation, Application and Use

Read entire product label, Technical Data Sheet (TDS) & Safety Data Sheet (SDS) before using.

Safety Precautions

- Immediately wash off the product with soap and water if it comes in contact with skin.
- Use product in a well-ventilated area.
- Keep away from heat, sparks & flames.
- If you scrape, sand or remove old paint from any surface, you may release lead dust. LEAD IS TOXIC. Contact the National Lead Hotline at 1-800-424-LEAD or www.epa.gov/lead.

Recommended Safety Equipment

- Chemical-resistant gloves must always be worn
- Clothing to cover all skin areas
- Eye protection
- Rubber boots
- Mask

Surface Preparation

Surface Preparation varies by surface. Please see chart below for specific surface preparation instructions.

Application Instructions

- Step 1:** For exterior applications, check weather conditions to be certain rain or dew is not imminent before the product has had the opportunity to dry fully after application.
- Step 2:** **TEST:** Dura Grip should be tested on a small inconspicuous area before full application.
- Step 3:** **MIXING:** Use paint shaker or hand stir to thoroughly mix before using. Stir occasionally during use.
- Step 4:** **APPLICATION:** Apply with a 3/8" nap roller in 1-2 coats (2 coats recommended). Using SlipDoctors 3/8" nap roller, apply Dura Grip in uniform coats applying with light even pressure. For best performance, avoid thick coats. Second coat should be applied at a right angle to the first coat.
- Step 5:** **CLEAN UP:** While Dura Grip is still wet, equipment may be cleaned with soap and water. Once dried, equipment may be cleaned with a solvent such as xylene or toluene.

Maintenance

For general cleaning and maintenance, use a light pressure rinsing. For best results to remove oily deposits or other foreign matter, apply pH-neutral cleaner at recommended dilution rate and scrub lightly with a soft bristle deck brush. Do not use alcohol-based cleaners, such as Pine-Sol or Fabuloso.

Surface Preparation

Surface Type	Instructions
All Surfaces	All substrates must be cleaned, dry and free of dust, dirt, oil, grease, soil, soap residue, wax, flaking paint and other soluble contaminants.
Metal/ Aluminum	Loose rust, mill scale and deteriorated previous coatings must be removed by hand tool or power tool cleaning. A power Brushoff Abrasive Blast may be used as an alternative to scraping and wire brushing. Scuff, sand and dull all slick hard, glossy surfaces to promote adhesion. Heavily rusted areas may require a Commercial Grade Blast to assure maximum coating performance. For maximum corrosion resistance, prime surface with SlipDoctors Primer. ALUMINUM SURFACES MUST BE SCUFFED AND/OR ETCHED WITH SLIPDOCTORS STONE GRIP BEFORE APPLICATION OF DURA GRIP S/B.
Uncoated Concrete	New concrete should be allowed to cure for 30 days before application of any coating. If there is any doubt about the dryness of the concrete, conduct a test by simply placing a weighted rubber mat, plastic sheet or other nonporous material on the surface for 24 hours. Check the underside of the mat and concrete for signs of moisture. The substrate will be darker if damp. If moisture is found, allow additional drying time (10-14 days) and repeat test. If moisture persists, the concrete surface cannot be coated.
Previously Coated Concrete	Lightly scuff surface to promote adhesion. Clean again ensuring surface is free of all dust and residue. Allow to completely dry and apply SlipDoctors Primer. Scuff, sand and power wash peeled of chipped paint to a sound surface. Once surface is free of coating lightly scuff surface to promote adhesion. Clean again ensuring surface is free of all dust and residue. Allow to completely dry and apply SlipDoctors Primer.
Wood	Patch all holes and imperfections with a wood filler or putty and sand smooth. Sand any exposed wood to a fresh surface. Mold and mildew must be cleaned with a chlorinated cleaner or bleach solution. Remove all surface contamination by washing with a pH-neutral cleaner, rinse thoroughly and allow to dry. Wood must be primed with SlipDoctors Primer before application of Dura Grip S/B.
Unsealed Tile/ Natural Stone	Surface should be lightly sanded with 220 grit sand paper or treated with SlipDoctors Stone Grip. Clean surface using pH-neutral cleaner, rinse and allow to thoroughly dry before application.

Precautions & Technical Support

Please refer to Safety Data Sheet (SDS) for detailed Precautions List and First Aid Instructions

Technical Support: Please contact SlipDoctors at 1-888-436-5404 or support@slipdoctors.com

Office Hours: Monday-Friday from 8:00 am – 5:00 pm CST.

Warranty & Disclaimer

WARRANTY: All properly installed SlipDoctors products are guaranteed to increase the coefficient of friction of your surface for 2 years (provided surface preparation and cleaning procedures are followed and no contaminants are present). If at any time during the warranty period the treated surface should lose its coefficient of friction, SlipDoctors shall at its option replace any product that proves defective. This warranty applies only to the product itself. Neither the seller nor the manufacturer shall be liable for any injury, loss or damage direct or consequential, arising out of the use or the inability to use the product. Before using, buyer shall determine the suitability of the product for the intended use, and the buyer assumes all risk and liability whatsoever in connection therewith. No statement or recommendation not contained herein shall have any force or effect unless in an agreement signed by seller and manufacturer. Buyer assumes all risks and responsibility associated with disposal. SlipDoctors cannot eliminate all possibilities of slip-and-fall accidents. Please visit www.slipdoctors.com to find further warranty information.

TYBEE ISLAND- MEMORIAL PARK PAVILION

VIA WET LED

PENDANT



LUMENWERX
WWW.LUMENWERX.COM



DESCRIPTION

Via Wet offers architectural lighting for wet locations in both exterior and interior applications. With a simple 3¾" high by 4½" wide profile of extruded aluminum, Via Wet can be installed in recessed, ceiling, wall, or pendant mounting.

Fully sealed, Via Wet is suitable for extreme weather condition, -20°C/-4°F to 40°C/104°F. A choice of output options provides up to 1000 lumens per foot section.

PROJECT: _____
 TYPE: _____
 NOTES: _____

IMPORTANT: Fixture must be installed with lens facing down.

ORDER GUIDE

VIAWETP			LED			
LUMINAIRE ID	PROTECTIVE OPTICS	OPTICS	LIGHT SOURCE	CRI	LUMEN PACKAGES	COLOR TEMP.
VIAWETP- via wet pendant	TMG - Tempered Clear Glass PYC - Clear Polycarbonated	HLO - High-Efficiency Lambertian Optic PMO - Precision Micro-Prism Optic	LED - high performance LED	80 - 80CRI 90 - 90CRI	500 - min. low output 500lm/ft 750 - medium output 750lm/ft 1000 - max. high output 1000lm/ft #### - other required lm/ft	27 - 2700k 30 - 3000k 35 - 3500k 40 - 4000k 50 - 5000k

LUMINAIRE LENGTH	VOLTAGE	DRIVER	ELECTRICAL	POWER FEED	55WSW18 MOUNTING	FINISH
Standard sections - 3', 4' For all other specify length #FT - nominal length in feet Continuous Run - 4' sections joint together	120 - 120V 277 - 277V UNV - 120V-277V 347 - 347V	D1 - 1% dimming 0-10V DA - Dali	1 - 1 circuit + EM - emergency light circuit + NL - night light circuit + GTD### - generator transfer device, 120V or 277V	TF - top feed	55WSW18 - power 5" + non power 5" white canopy & stem (18" stem) For all other options refer to our Pendant Mounting Guide	W - matte white AL - aluminum CF# - custom finish specify RAL#

See page 2 for ordering code detailed information

CROSS SECTION

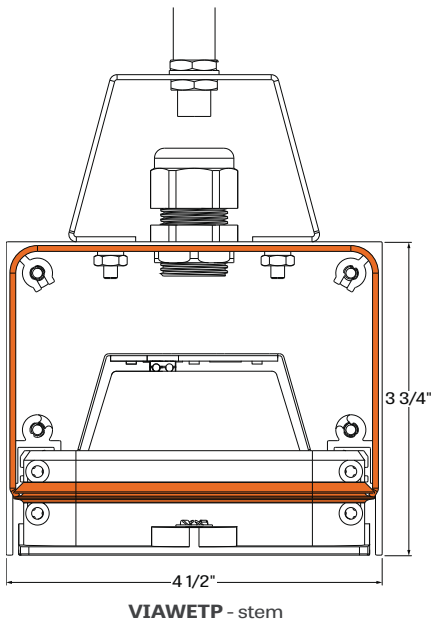

OPTICS AND PROTECTIVE OPTICS



TMG + HLO - Tempered Clear Glass with High Efficiency Lambertian Optic



ROW CONFIGURATIONS AND MOUNTING SPACING

LUMINAIRE LENGTHS AND ENDCAPS

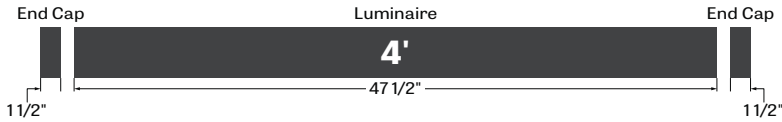
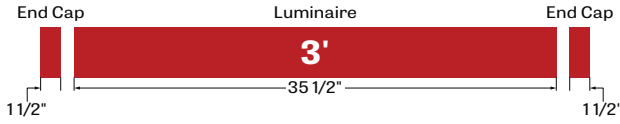

ROW CONFIGURATIONS AND MOUNTING SPACING

SECTIONS		TOTAL LENGTH	
3ft	4ft	Nominal	Actual
1X		3'	38 1/2"
	1X	4'	50 1/2"

DMP = Distance between Mounting Points

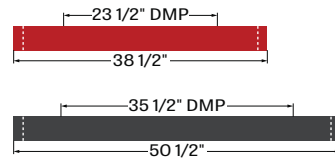

3D LUMINAIRE JOINING SECTION

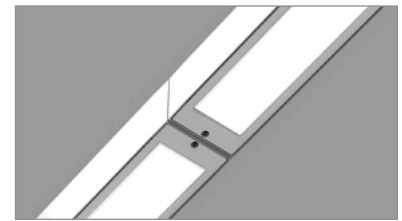

2X		6'	77 1/16"
1X	1X	7'	89 1/16"
	2X	8'	101 1/16"
3X		9'	115 5/8"
2X	1X	10'	127 5/8"
1X	2X	11'	139 5/8"
	3X	12'	151 5/8"

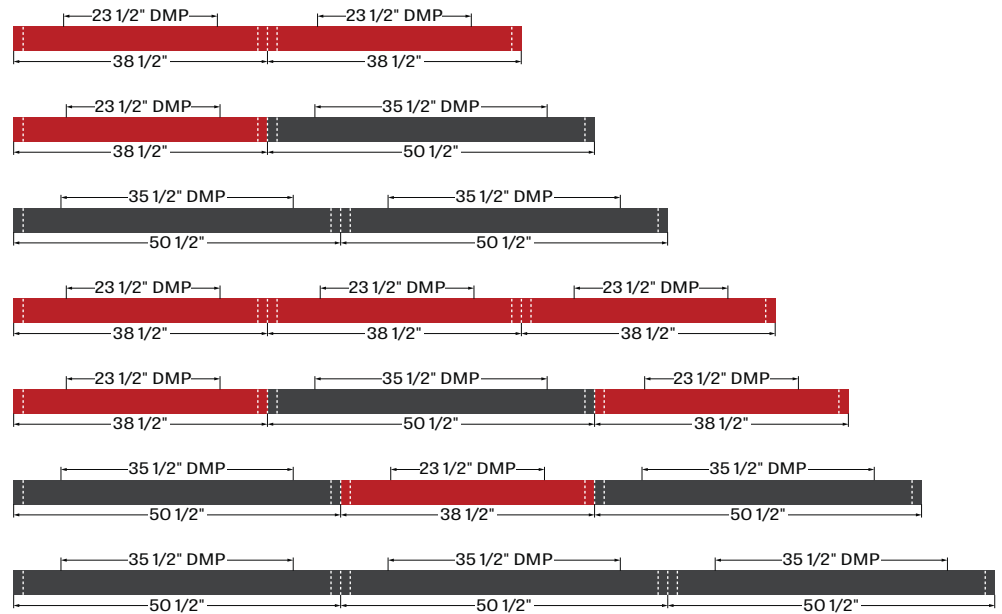

For longer run please use the same logic

OPTICS AND PROTECTIVE OPTICS

Via Wet is available with a clear tempered glass (**TMG**) or a clear, UV stabilized polycarbonate (**PYC**) protective enclosure, which are installed outside of the luminaire optic itself.

The Precision Micro Optic (**PMO**) option utilizes a special catadioptric lens with a two-dimensional array of prisms designed to eliminate glare while maintaining high efficiency and clean luminous appearance. The High efficiency Lambertian Optic (**HLO**) option uses a diffuser that combines 88% transmission with good source obscuration.

LIGHT SOURCE - LED

Custom linear array of mid-flux LED's are cartridge-mounted with quick-connect wiring to facilitate service and thermal management. Available in 3000K, 3500K and 4000K with a minimum 80 CRI and an option for 90 CRI with elevated R9 value. Color consistency maintained to within 3 SDCM. LEDs operated at reduced drive current to optimize efficacy and lumen maintenance.

All LEDs have been tested in accordance with IESNA LM-80-08 and the results have shown L80 lumen maintenance greater than 60,000 hours. Absolute product photometry is measured and presented in accordance with IESNA LM-79, unless otherwise indicated.

PERFORMANCE PER 4' AT 4000K

LED output	Color Temp	Watts	Nominal Delivered Lumens	Efficacy LPW
low output	4000K	22	2000	92
medium output	4000K	33.5	3000	90
high output	4000K	45.5	4000	88

LUMINAIRE LENGTH

Via Wet is made up of standard 3, and 4 foot sections that can be joined cleanly and securely for continuous runs in all configurations.

Joining system

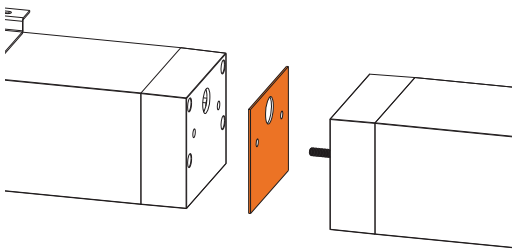

All individual sections are joined together onsite using the 1/4"-20 screws and nuts provided. The joint between 2 adjacent individual sections is sealed by a silicone gasket attached to one of the 2 sections. The electrical connection between sections is made through the holes provided in the end-caps.

ELECTRICAL

Factory-set adjustable output current electronic driver with universal (120-277VAC) input. Dimmable from 100% to 1% with 0-10V dimming control. Rated life (90% survivorship) of 50,000 hours at -20°C min. and 40°C max. ambient (and 70°C max. case) temperature. At maximum driver load: Efficiency > 84%, PF > 0.9, THD < 20%. DMX (RDM compatible) and DALI protocol drivers are also available. Low-temperature, -40°C rated, 0-10V (10% minimum) dimming drivers are also available upon request. Power grommet for cable diameter between 0.276" and 0.512" (7-13mm). All of our standard 0-10V drivers are NEMA 410 compliant.

MOUNTING OPTIONS

Fixtures can be pendant-mounted using stem. Unless otherwise specified, LumenWerx provides 55WSW18 (5" white canopy for all power mounting point, and non power mounting point, and a 18" white stem)

[For all other options, see our website for a detailed Pendant Mounting Guide](#)

GASKETTED FIXTURE MOUNTING OPTIONS

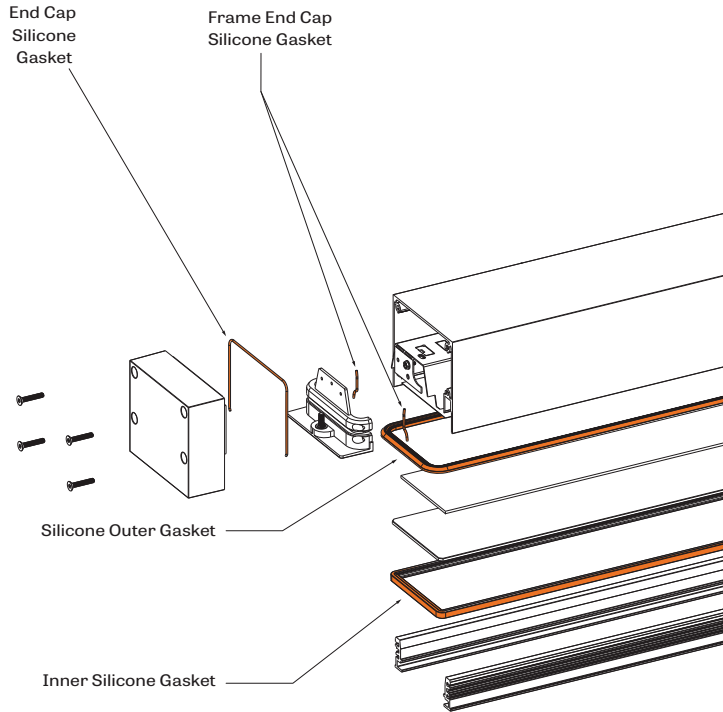

Lens and enclosure are sealed with inner and outer silicone gaskets

FINISH

Interior - 95%, reflective matte powder coated white paint

Exterior - matte white or aluminum powder coating.

Custom finishes are also available.

CONSTRUCTION

Housing - Extruded Aluminum (0.095" nominal) up to 90% Recycled Content

Side frame extrusions - Extruded Aluminum (0.125" nominal) up to 90% Recycled Content

Interior brackets - Die formed cold rolled sheet steel 16 gauge thick

Joining system - 2 x 1/4"-20 screws + nuts accessible from inside the fixture + one silicone gasket attached to one of the end-caps.

Reflectors - Flat rolled Aluminum sheet 0.040" thick precisely die formed, 95% reflective matte white painted

End Cap - Aluminum Die Cast

Stem - 0.5" diameter threaded steel tube matte white or aluminum powder coating. Custom finishes are also available

Tempered Clear Glass - clear, 1/8" thickness, fully tempered optics.

Polycarbonated - clear, 1/8" thickness, UV protected optics.

Gaskets - Fixture lens unit and end-caps are fully sealed using silicone gaskets.

Power grommet - EPDM rubber rated IP67.

WEIGHT

Via Wet 4ft - 18.2lbs - 8.27kg

CERTIFICATIONS

ETL - Rated for Wet location. Conforms to UL Standard 1598 and certified to CAN/CSA Standard C22.2 No. 250.0.

WARRANTY

LumenWerx provides a three-year limited warranty of electrical and mechanical performance of the luminaires, including the LED boards, drivers, and auxiliary electronics. LumenWerx will repair or replace defective luminaires or components at our discretion, provided they have been installed and operated in accordance with our specifications. Other limitations apply, please refer to the full warranty on our website.

500 LUMEN AT 80CRI - LOW OUTPUT

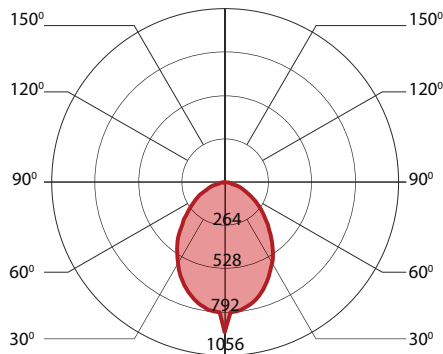

PERFORMANCE PER 4'

LED output	Color Temp	Watts	Nominal Delivered Lumens	Efficacy LPW
low output	3000K	23	2000	86
low output	3500K	22.5	2000	89
low output	4000K	22	2000	92
low output	5000K	21	2000	96

750 LUMEN AT 80CRI - MEDIUM OUTPUT

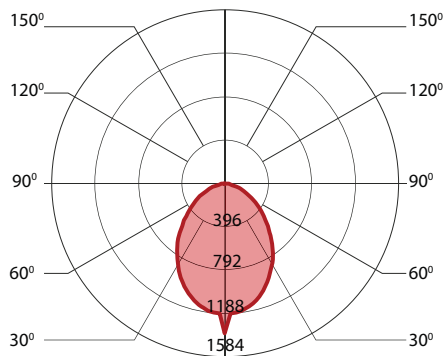

PERFORMANCE PER 4'

LED output	Color Temp	Watts	Nominal Delivered Lumens	Efficacy LPW
medium output	3000K	35.5	3000	84
medium output	3500K	34.5	3000	87
medium output	4000K	33.5	3000	90
medium output	5000K	32	3000	94

1000 LUMEN AT 80CRI - HIGH OUTPUT

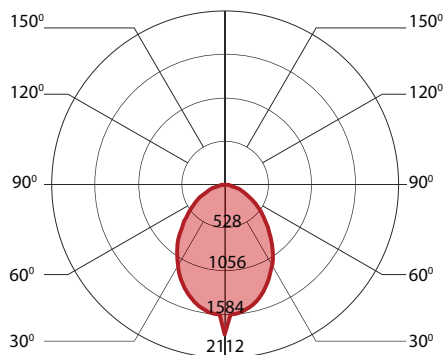

PERFORMANCE PER 4'

LED output	Color Temp	Watts	Nominal Delivered Lumens	Efficacy LPW
high output	3000K	49	4000	82
high output	3500K	47	4000	85
high output	4000K	45.5	4000	88
high output	5000K	43.5	4000	92

SECTION 099113 - PAINTING

PART 1 - GENERAL

1.1 SUMMARY

- A. This Section includes surface preparation and the application of paint systems on the following exterior substrates:
 - 1. Steel.
 - 2. Cement Board siding and trim
 - 3. Wood Siding and trim

1.2 SUBMITTALS

- A. Product Data: For each type of product indicated.
- B. Samples: For each finish and for each color and texture required.
- C. Product List: Printout of current "MPI Approved Products List" for each product category specified in Part 2, with the proposed product highlighted.

1.3 QUALITY ASSURANCE

- A. MPI Standards:
 - 1. Products: Complying with MPI standards indicated and listed in "MPI Approved Products List."
 - 2. Preparation and Workmanship: Comply with requirements in "MPI Architectural Painting Specification Manual" for products and paint systems indicated.
- B. Mockups: Apply benchmark samples of each paint system indicated and each color and finish selected to verify preliminary selections made under sample submittals and to demonstrate aesthetic effects and set quality standards for materials and execution.
 - 1. Architect will select one surface to represent surfaces and conditions for application of each paint system specified in Part 3.
 - a. Vertical and Horizontal Surfaces: Provide samples of at least 100 sq. ft. (9 sq. m).
 - b. Other Items: Architect will designate items or areas required.
 - 2. Final approval of color selections will be based on benchmark samples.

- a. If preliminary color selections are not approved, apply additional benchmark samples of additional colors selected by Architect at no added cost to Owner.

1.4 EXTRA MATERIALS

- A. Furnish extra materials described below that are from same production run (batch mix) as materials applied and that are packaged for storage and identified with labels describing contents.

1. Quantity: Furnish an additional 2 gal. (3.8 L) of each material and color applied.

PART 2 - PRODUCTS

2.1 PAINT, GENERAL

- A. Material Compatibility:

1. Provide materials for use within each paint system that are compatible with one another and substrates indicated, under conditions of service and application as demonstrated by manufacturer, based on testing and field experience.
2. For each coat in a paint system, provide products recommended in writing by manufacturers of topcoat for use in paint system and on substrate indicated.

- B. Colors: As indicated on the drawings.

2.2 METAL PRIMERS

- A. Quick-Drying Alkyd Metal Primer: MPI #76.

1. VOC Content: E Range of E1.

2.3 EXTERIOR ALKYD PAINTS

- A. Exterior Alkyd Enamel (Gloss): MPI #9 (Gloss Level 6).

1. VOC Content: E Range of E1.

PART 3 - EXECUTION

3.1 EXAMINATION

- A. Examine substrates and conditions, with Applicator present, for compliance with requirements for maximum moisture content and other conditions affecting performance of work.
- B. Maximum Moisture Content of Substrates: When measured with an electronic moisture meter as follows:
 - 1. Concrete: 12 percent.
 - 2. Masonry (Clay and CMU): 12 percent.
 - 3. Wood: 15 percent.
 - 4. Plaster: 12 percent.
 - 5. Gypsum Board: 12 percent.
- C. Verify suitability of substrates, including surface conditions and compatibility with existing finishes and primers.
- D. Begin coating application only after unsatisfactory conditions have been corrected and surfaces are dry.
 - 1. Beginning coating application constitutes Contractor's acceptance of substrates and conditions.

3.2 PREPARATION AND APPLICATION

- A. Comply with manufacturer's written instructions and recommendations in "MPI Architectural Painting Specification Manual" applicable to substrates and paint systems indicated.
- B. Clean substrates of substances that could impair bond of paints, including dirt, oil, grease, and incompatible paints and encapsulants.
 - 1. Remove incompatible primers and reprime substrate with compatible primers as required to produce paint systems indicated.
- C. Apply paints to produce surface films without cloudiness, spotting, holidays, laps, brush marks, roller tracking, runs, sags, ropiness, or other surface imperfections. Cut in sharp lines and color breaks.
- D. Protect work of other trades against damage from paint application. Correct damage to work of other trades by cleaning, repairing, replacing, and refinishing, as approved by Architect, and leave in an undamaged condition.

- E. At completion of construction activities of other trades, touch up and restore damaged or defaced painted surfaces.

3.3 PAINTING SCHEDULE

A. Steel Substrates:

- 1. Alkyd System: MPI EXT 5.1D.
 - a. Prime Coat: Alkyd anticorrosive metal primer.
 - b. Intermediate Coat: Exterior alkyd enamel matching topcoat.
 - c. Topcoat: Exterior alkyd enamel (gloss).

B. Cement Siding and Wood Substrates: Including siding, fascias, soffits and trim.

- 1. Latex System:
 - a. Prime Coat: Alkaline resistant primer. **Sherwin Williams “Loxon”**.
 - b. Intermediate Coat: Exterior latex matching topcoat.
 - c. Topcoat: **Sherwin Williams “Resilience”, Satin finish.**

END OF SECTION 099113



City of Tybee Island

Memorandum

To: City of Tybee Island City Council Members
From: Pete Gulbranson, City Engineer/Director of Infrastructure
Date: November 6, 2020
Re: Non -Award of ITB 2020-755: Memorial Park Pavilion

Background

The purpose of this project was to remove and replace the failing roof on the open air pavilion in Memorial Park, due to structure damage and dry rot. The City advertised for bids and bids were opened on October 27, 2020 at 2:00 P.M.

Overview

The City received bids from five General Contractors, but one bid was not opened due to the company not acknowledging the addendum. The bids were opened and they ranged from the low bid of \$112,950 to the high bid of \$255,555.

Summary

The construction estimate for this project was \$50,000 and since all bids came over budget they project cannot be completed in this current budget cycle.

Recommended Next Steps:

I would recommend not awarding the bid to the lowest bid and have City forces proceed with the roof replacement.

File Attachments for Item:

11. Second Reading, 2020-20, Noise Ordinance

ORDINANCE NO. 2020-20

AN ORDINANCE TO AMEND THE CODE OF ORDINANCES OF THE CITY OF TYBEE ISLAND SO AS TO REVISE PROVISIONS ADDRESSING PROHIBITED NOISE THAT IS UNREASONABLY LOUD, RAUCOUS, JARRING, DISTURBING OR A NUISANCE WITHIN THE AREA OF AUDIBILITY AND TO REPEAL INCONSISTENT OR CONFLICTING ORDINANCES AND TO ELIMINATE PROVISIONS REGARDING DECIBEL LEVELS FOR THE CONTROL OR MEASUREMENT OF NOISE AND SUBSTITUTING IN LIEU THEREOF A STANDARD OF PLAINLY AUDIBLE FROM A SPECIFIED DISTANCE FOR DETERMINATIONS OF OFFENSIVE OR PROHIBITED NOISE AND TO RECOGNIZE THE ADOPTION OF CIVIL PENALTIES FOR OFFENSES INCLUDING PROHIBITED NOISE, FOR THE REPEAL OR CONFLICTING ORDINANCES, TO ESTABLISH AN EFFECTIVE DATE AND TO AUTHORIZE THE ENFORCEMENT THEREOF

WHEREAS, the duly elected governing authority for the City of Tybee Island, Georgia, is authorized under Article 9, Section 2, Paragraph 3 of the Constitution of the State of Georgia to adopt reasonable ordinances to protect and improve the public health, safety, and welfare of the citizens of Tybee Island, Georgia, and

WHEREAS, the duly elected governing authority for the City of Tybee Island, Georgia, is the Mayor and Council thereof; and

WHEREAS, the governing authority desires to adopt ordinances under its police and home rule powers; and

WHEREAS, the control of sound and sound making devices which produce noise at levels that are unreasonably loud, raucous, jarring, disturbing or a nuisance to persons within the area of audibility is necessary for the peace and wellbeing of residents and visitors to the City; and

WHEREAS, Tybee Island is unique in the location of business establishments, a county pier where events are conducted and residential dwellings that coexist in close proximity to commercial establishments that provide gatherings, music and other sources of sound; and

WHEREAS, wind directions and wind speed can have significant impacts on the distribution of sounds; and

WHEREAS, the City of Tybee Island has for in excess of 15 years explored alternative methods of addressing noise, noise complaints, disorderly behavior in various residential and other areas; and

WHEREAS, the City has attempted to improve the peace, tranquility and health and safety of residents and occupants of residential dwellings by controlling or limiting unreasonably loud noises through sound level controls based on decibel levels and in the opinion of many, the efforts have not been as successful as desired; and

WHEREAS, court decisions upholding the constitutionality of the restrictions on noise and noise producing activity where doing so creates "plainly audible" disturbances too occupants of nearby properties have been recognized and resulted in successful prohibitions and prosecutions; and

WHEREAS, the City of Tybee Island has previously adopted administrative procedures for civil penalties for certain Code violations which can include unreasonably loud noise violations;

NOW THEREFORE, it is hereby ordained by the governing authority of the City of Tybee Island duly assembled as follows:

SECTION I

Existing Tybee Code Sections identified as Article 4 of Chapter 22 "Noises" Sections 22-110 through 22-112 are hereby repealed in their entirety and are replaced with the Code Sections hereinafter set forth and designated numerically as hereinafter set forth.

ARTICLE IV. NOISES

Sec. 22-110. Definitions.

The following words, terms and phrases, when used in this article, shall have the meanings ascribed to them in this section, except where the context clearly indicates a different meaning:

Construction means any site preparation, assembly, erection, substantial repair, alteration, or similar action, for or of public or private rights-of-way, structures, utilities, or similar property.

Demolition means any dismantling, intentional destruction or removal of structures, utilities, public or private right-of-way surfaces, or similar property.

Emergency means any occurrence or set of circumstances involving actual or imminent physical or psychological trauma or property damage which demands immediate action.

Emergency work means any work performed for the purpose of alleviating or resolving an emergency.

Enclosed Building means all space between a floor and ceiling that is enclosed on all sides by solid walls or windows, exclusive of doorways, which extend from the floor to the ceiling.

Holidays means those holidays recognized by the U.S. Office of Personnel Management.

Mechanical Sound Making Devices means any radio receiving device, television, stereo, musical instrument, phonograph sound amplifier or other machines or devices for the producing, reproducing or amplifying of sound and/or noise.

Motor vehicle means any motor-operated vehicle licensed for use on the public highways, but not including a motorcycle.

Motorboat means any vessel which operates on water and which is propelled by a motor, including, but not limited to, boats, barges, amphibious craft, water ski towing devices and hover craft.

Motorcycle means any motor vehicle having a saddle or seat for the use of the rider and designed to travel on not more than three wheels in contact with the ground. The term shall include, but not be limited to, motorized bicycles and motor scooters.

Noise means any sound which disturbs humans or which causes or tends to cause an adverse psychological or physiological effect on humans.

Noisy Assembly means any gathering of more than one (1) person which creates noise.

Noise disturbance means any sound which endangers or injures the welfare, safety or health of human beings, or disturbs a reasonable person of normal sensitivities, or devalues or injures personal or real property, or is hereinafter defined.

Noise sensitive activities means activities which should be conducted under conditions of exceptional quiet including, but not limited to, operation of schools, libraries open to the public, churches, hospitals, and nursing homes.

Noise sensitive area means any area designated for the purpose of ensuring exceptional quiet and clearly posted with "noise sensitive area" signs, because of the noise sensitive activities conducted therein.

Official Public event means any event put on by, adopted, approved or endorsed by the City.

Person means any individual, partnership, firm, association, joint venture, public or private corporation, trust, estate, commission, board, public or private institution, utility, operative, state agency, municipality or other political subdivisions of this state, any interstate body, or any other legal entity.

Plainly audible shall mean any sound emanating from the specific sound-producing sources set forth below which can be heard from the distances set forth below, using the following sound measurement standards: Measurement shall be by the auditory senses of a person standing at a distance no less than the required minimum distance from the source of the sound. For music and other noise, words and phrases need not be discernable. For music and other noise, bass reverberations are included.

Powered model vehicle means any self-propelled airborne, waterborne, or land borne model plane, vessel, or vehicle, which is not designed to carry persons, including, but not limited to any model airplane, boat, car or rocket.

Public right-of-way means any street, avenue, boulevard, highway, sidewalk, lane or similar place which is owned or controlled by a governmental entity.

Public space means any real property, including any structure thereon, which is owned or controlled by a governmental entity.

Public works project means any project financed by public funds such as roads, highways, bridges or other construction on public or government owned property. It does not include projects merely approved by mayor and council.

Real property boundary means an imaginary line along the ground surface, and its vertical extension, which separates the real property owned by one person from that owned by another person, but not including intra-building real property divisions.

Residential means any property on which is located a building or structure used wholly or partially for living or sleeping purposes.

School means any place of learning or caring for children, both public and private.

Sound means an oscillation in pressure, particle displacement, particle velocity or other physical parameter, in a medium with internal forces that cause compression and rarefaction of that medium.

The description of sound may include any characteristic of such sound, including duration, intensity and frequency.

Used means and includes the words "intended," "designed," or "arranged to be used. "
(Code 1983, § 11-3-2)

Sec. 22-111. Exceptions.

The provisions of this article shall not apply to:

- (1) The emission of sound for the purpose of alerting persons to the existence of an emergency;
- (2) The emission of sound in the performance of emergency work by City or City Contractor;
- (3) Noises and/or sounds caused to be made by manufacturing, governmental, or commercial entities in the normal course of their business, however, the production of sound by gathering of persons, music or entertainment activities by restaurants, bars and/or similar establishments shall not be exempt under this subsection;
- (~~3~~4) Agricultural activities, exclusive of those involving the ownership or possession of animals or birds;
- (~~5~~4) Public mass transportation vehicles;
- (~~6~~5) Church or clock carillons, bells, or chimes;
- (~~7~~6) The emission of sound in the discharge of weapons or in fireworks displays for which a permit has been issued;
- (~~8~~7) Public works projects;
- (~~9~~8) Noises and/or sounds that are permitted by a special event permit pursuant to section 54-70, et seq; provided, however, that the producer or coordinator of the special event must comply with the terms, restrictions and conditions of the special event permit;
- (~~10~~9) Sound volumes produced by radio, tape player, or other mechanical sound making device or instrument from within a motor vehicle on a street or highway, which sound is controlled by O.C.G.A. § 40-6-14;
- (~~11~~0) Noises or sounds made by law enforcement and other public safety officials performing their public functions;
- (~~12~~4) The emission of sound from a public space during an official public event; or
- (~~13~~2) The emission of sound from a school or church during the regular scheduled hours of operation or during special events.
(Code 1983, § 11-3-3)
- (14) Noises or sounds made by the exploding of consumer fireworks on January 1, the last Saturday and Sunday in May, July 3, July 4, the first Monday in September, and December 31 of each year after 10:00 a.m. and up to and including the time of 11:59 p.m.; and on January 1 of each year beginning at the time of 12:00 Midnight and up to and including the ending time of 1:00 a.m.
- (15) Generators during times of power outages.

Sec. 22-112. Noise disturbance prohibited.

(a) *Prohibited conduct.*

(1) *Restrictions of 300 feet for 7:00 a.m. through 10:00 p.m. Sunday through Thursday and 7:00 a.m. through 12:00 midnight on Friday and Saturday and holidays.*

a. *Mechanical sound-making devices.* It is unlawful for any person or persons to play, use, operate, or permit to be played, used, or operated any Mechanical Sound Making Devices at such a volume and in such a manner so as to create, or cause to be created, any noises or sounds which are plainly audible at a distance of 300 feet or more from the building, structure or vehicle, or in the case of real property, beyond the property limits, in which it is located, whichever is farthest, between the hours of 7:00 a.m. and 10:00 p.m. Sunday through Thursday and between the hours of 7:00 a.m. and 12:00 midnight on Friday and Saturday and holidays.

b. *Human-produced sounds.* It is unlawful for any person or persons to yell, shout, whistle, or sing on the public streets or sidewalks or on private property so as to create, or cause to be created, any noises or sounds which are plainly audible at a distance of 300 feet or more from the place, building, structure, or in the case of real property, beyond the real property boundary, in which the person is located, whichever is farthest, between the hours of 7:00 a.m. and 10:00 p.m. Sunday through Thursday and between the hours of 7:00 a.m. and 12:00 midnight on Friday and Saturday and holidays.

c. *Commercial advertising.* It is unlawful for any person or persons to use, operate, or permit to be used or operated any radio receiving device, musical instrument, phonograph, loud speaker, sound amplifier or other machine or device for the production or reproduction of sound which is cast upon the public streets or other public property for the purpose of commercial advertising or which serves to attract the attention of the public to any building, structure or vehicle in such a manner so as to create, or cause to be created, any noises or sounds which are plainly audible at a distance of 300 feet or more from the source of the sound cast upon the public streets or other public property or from the building, structure, or in the case of real property, beyond the real property boundary, in which it is located, whichever is farthest, between the hours of 7:00 a.m. and 10:00 p.m. Sunday through Thursday and between the hours of 7:00 a.m. and 12 midnight on Friday and Saturday and holidays.

d. *Party noise.* It is unlawful for any person or persons in charge of a party or other social event that occurs on any private property to allow that party or social event to produce noise in such a manner that such noise is plainly audible at a distance of 300 feet or more from the building or structure from which the noise is emanating or in the case of real property, beyond the real property boundary, on which the party or social event is located, whichever is farthest, between the hours of 7:00 a.m. and 10:00 p.m. Sunday through Thursday and between the hours of 7:00 a.m. and 12:00 midnight on Friday and Saturday and holidays. For the purposes of this subsection, a "person in charge of a party or other social event" shall mean any adult person who resides in or on the premises involved in such party or social event or the adult responsible for having leased, rented or who manages the property or is otherwise responsible therefore and is present at such party or social event. For the purposes of this subsection, "noise" shall mean the same sounds, or any combination thereof, as described in paragraphs a. or b. above.

(2) *Restrictions of 100 feet for 10:00 p.m. through 7:00 a.m. Sunday through Thursday and 12:00 midnight through 7:00 a.m. on Saturday and Sunday and holidays.*

a. *Mechanical sound-making devices.* It is unlawful for any person or persons to play, use, operate, or permit to be played, used, or operated any Mechanical Sound Making Devices at such a volume and in such a manner so as to create, or cause to be created, any noises or sounds which are plainly audible at a distance of ~~3~~100 feet or more from the building, structure or vehicle, or in the case of real property, beyond the property limits, in which it is located, whichever is farthest, between the hours of ~~14~~10:00 p.m. and 7:00 a.m. Sunday through Thursday and between the hours of 12:00 midnight and 7:00 a.m. on Friday and Saturday and holidays.

b. *Human-produced sound.* It is unlawful for any person or persons to yell, shout, hoot, whistle, or sing on the public streets or sidewalks or on private property so as to create, or cause to be created, any noises or sounds which are plainly audible at a distance of 100 feet or more from the place on public streets and sidewalks, or in the case of private real property, beyond the real property boundary, on which the person is located, whichever is farthest, between the hours of ~~14~~10:00 p.m. and 7:00 a.m. Sunday through Thursday and between the hours of ~~12~~10:00 p.m. ~~midnight~~ and 7:00 a.m. on Saturday and Sunday and holidays.

c. *Commercial advertising.* It is unlawful for any person or persons to use, operate, or permit to be used or operated any radio receiving device, musical instrument, phonograph, loud speaker, sound amplifier or other machine or device for the production or reproduction of sound which is cast upon the public streets or other public property for the purpose of commercial advertising or which serves to attract the attention of the public to any building, structure or vehicle in such a manner so as to create, or cause to be created, any noises or sounds which are plainly audible at a distance of 100 feet or more from the source of the sound cast upon the public streets or other public property or from the building, structure, or in the case of real property, beyond the real property boundary, in which it is located, whichever is farthest, between the hours of ~~_____~~10:00 p.m. and ~~_____~~7:00 a.m. Sunday through Thursday and between the hours of ~~_____~~12:00 midnight and ~~_____~~7:00 a.m. on Saturday and Sunday and holidays.

d. *Party noise.* It is unlawful for any person or persons in charge of a party or other social event that occurs on any private property to allow that party or event to produce noise in such a manner so as to such noise is plainly audible at a distance of 100 feet or more from the building or structure from which the party noise is emanating or in the case of real property, beyond the real property boundary, on which the party or social event is located, whichever is farthest, between the hours of ~~_____~~10:00 p.m. and ~~_____~~7:00 a.m. Sunday through Thursday and between the hours of 10:00 p.m. ~~_____~~ and ~~_____~~7:00 a.m. on Saturday and Sunday and holidays. For the purposes of this subsection, a "person in charge of a party or other social event" shall mean any adult person who resides in or on the premises involved in such party or social event and is present at such party or social event or the adult responsible for having leased, rented or who manages the property or is otherwise responsible therefore. For the purposes of this subsection, "noise" shall mean the same sounds, or any combination thereof, as described in paragraphs a. or b. above.

(3) Restrictions regarding noise produced by consumer fireworks between 10:00 a.m. and up to and including 11:59 p.m. on all days. It is unlawful for any person to use, explode or cause to be exploded any consumer fireworks to produce noise in such a manner that such noise is plainly audible at a distance of 100 feet or more from the place, or in the case of real property, beyond the

property limits in which the fireworks are being used, exploded or caused to be exploded, whichever is farthest, between the hours of 10:00 a.m. and 11:59 p.m. on all days. For the purposes of this section, the term "consumer fireworks" shall have the meaning set forth in O.C.G.A. § 25-10-1(a)(1), but such term shall not include those items excluded therefrom in O.C.G.A. § 25-10-1(b) as such code section is enacted as of July 1, 2018 or as may be amended in the future. See also, Sec. 42-66, and O.C.G.A. § 25-10-2 prohibiting the use of such fireworks after 11:59 p.m. except as specifically authorized.

(34) *Restrictions for areas within apartments, condominiums, townhouses, duplexes, or other such residential dwelling units.*

Except for persons within commercial enterprises that have an adjoining property line or boundary with a residential dwelling unit, it is unlawful for any person to make, continue, or cause to be made or continued any noise in such a manner as to be plainly audible to any other person a distance of five feet beyond the adjoining property line wall or boundary of any apartment, condominium, townhouse, duplex, or other such residential dwelling units with adjoining points of contact.

For the purposes of this subsection, "noise" shall mean human-produced sounds of yelling, shouting, ~~hoating~~, whistling, singing, or mechanically-produced sounds made by radio-receiving device, television, stereo, musical instrument, phonograph sound amplifier or other machines or devices for the producing, reproducing, or amplifying of sound, or any combination thereof.

For the purposes of this subsection, "property line or boundary" shall mean an imaginary line drawn through the points of contact of (1) adjoining apartments, condominiums, townhouses, duplexes or other such residential dwelling units with adjoining points owned, rented, or leased by different persons; or (2) adjoining common areas or adjoining exterior walls. Said property line or boundary includes all points of a plane formed by projecting the property line or boundary including the ceiling, the floor, and the walls.

(b) For Property bordering residential (not to exclude property separated by a right of way, street or easement, public or private) including other residential property bordering Residential.

In addition to all other provisions of this Article, if the property boundary of a property borders residential property, the following shall apply:

- (1) It shall be unlawful for any person or persons to play, use, operate, or permit to be played, used, or operated any Mechanical Sound Making Devices between the hours of 10:00 p.m. and 7:00 a.m. Sunday through Thursday and 12:00 ~~p.m.~~ midnight through 7:00 a.m. Friday and Saturday and holidays, unless the music is played exclusively within an enclosed building. In addition to the foregoing, any use or operation of any Mechanical Sound Making Devices between the restricted hours which produces noises that are plainly audible from the property boundary of the property is a violation of this section.

(2) It shall be unlawful for any person or persons to constitute a Noisy Assembly, or permit property under his or her control to be used for a Noisy Assembly, between the hours of ~~10:00~~ 10:00 p.m. and ~~7:00~~ 7:00 a.m. Sunday through Thursday. ~~And 11:00~~ 11:00 p.m. through ~~7:00~~ 7:00 a.m. Friday and Saturday and holidays, unless the Noisy Assembly is exclusively within an enclosed building. In addition to the foregoing, any Noisy Assembly between the restricted hours which produces noises than are plainly audible from the property boundary of the property is a violation of this section.

(c) *Equipment use restrictions.* Regardless of the other provisions of this Article, the following equipment may not be operated between the ~~time of sunset hours of 8:00 p.m.~~ and 7:00 a.m.: Monday-Friday and on Saturday and Sunday ~~the time of sunset 8:00 p.m.~~ to 10:00 a.m.:

- (1) Electrical power tools.
- (2) Motor powered, muffler equipped lawn, garden, and tree trimming equipment except residential lawn mowers.
- (3) Construction equipment, which includes landscaper's lawn mowers and other landscaping motorized equipment.
- (4) Construction noise . Between the hours of 11:00 p.m. and 6:00 a.m., construction noise of any type, including, but not limited to, noise caused by the erection (including excavation), demolition, alteration, or repair of any building, as well as the operation of any earth-moving equipment, crane, saw, drill, pile driver, steam shovel, pneumatic hammer, hoist, automatic nailer or stapler, or any similar equipment, shall not be plainly audible within any residential zoning district more than 100 feet beyond the property boundary of the property from which the noise emanates.

A variance from the above-referenced hours of operation for construction noise may be requested, in writing, at least 48 hours prior to the proposed construction operation, for consideration by the Director of the Building Inspections and Permit Department. Such a request shall state:

- 1)The reasons that support a claim of urgent need based on specific loss or inconvenience for such a variation from the allowable work hours;
- 2)The impact that the denial of this request would have on the applicant's project and the surrounding properties;
- 3)The steps which have been taken by the applicant to communicate those needs and impacts to owners of surrounding and nearby properties;
- 4)The steps that have or will be taken to limit the impact of the proposed activity upon surrounding and nearby properties; and
- 5)The possible risks to public health and safety.

If the Director finds that the application adequately demonstrates the urgent need for a variance from the above allowable work hours, adequately provides for mitigation of the impact upon surrounding and nearby properties, and poses no additional risk to public health and safety, then permission shall be granted for a variance to alter the allowable work hours during one ten-day period.

(Code 1983, § 11-3-4; Ord. of 4-29-2005; Ord. of 7-26-2007)

SECTION II

All ordinances and parts of ordinances in conflict herewith are expressly repealed.

SECTION III

It is the intention of the governing body, and it is hereby ordained, that the provisions of this ordinance shall become effective and be made a part of the Code of Ordinances, City of Tybee Island, Georgia, and the sections of this ordinance may be renumbered to accomplish such intention.

SECTION IV

This ordinance shall be effective upon its adoption by the Mayor and Council pursuant to The Code of the City of Tybee Island, Georgia.

This Ordinance shall become effective on _____ day of _____, 2020.

ADOPTED THIS ____ DAY OF _____, 2020.

MAYOR

ATTEST:

CLERK OF COUNCIL

FIRST READING: _____

SECOND READING: _____

ENACTED: _____

ORDINANCE NO. 2020-20

AN ORDINANCE TO AMEND THE CODE OF ORDINANCES OF THE CITY OF TYBEE ISLAND SO AS TO REVISE PROVISIONS ADDRESSING PROHIBITED NOISE THAT IS UNREASONABLY LOUD, RAUCOUS, JARRING, DISTURBING OR A NUISANCE WITHIN THE AREA OF AUDIBILITY AND TO REPEAL INCONSISTENT OR CONFLICTING ORDINANCES AND TO ELIMINATE PROVISIONS REGARDING DECIBEL LEVELS FOR THE CONTROL OR MEASUREMENT OF NOISE AND SUBSTITUTING IN LIEU THEREOF A STANDARD OF PLAINLY AUDIBLE FROM A SPECIFIED DISTANCE FOR DETERMINATIONS OF OFFENSIVE OR PROHIBITED NOISE AND TO RECOGNIZE THE ADOPTION OF CIVIL PENALTIES FOR OFFENSES INCLUDING PROHIBITED NOISE, FOR THE REPEAL OR CONFLICTING ORDINANCES, TO ESTABLISH AN EFFECTIVE DATE AND TO AUTHORIZE THE ENFORCEMENT THEREOF

WHEREAS, the duly elected governing authority for the City of Tybee Island, Georgia, is authorized under Article 9, Section 2, Paragraph 3 of the Constitution of the State of Georgia to adopt reasonable ordinances to protect and improve the public health, safety, and welfare of the citizens of Tybee Island, Georgia, and

WHEREAS, the duly elected governing authority for the City of Tybee Island, Georgia, is the Mayor and Council thereof; and

WHEREAS, the governing authority desires to adopt ordinances under its police and home rule powers; and

WHEREAS, the control of sound and sound making devices which produce noise at levels that are unreasonably loud, raucous, jarring, disturbing or a nuisance to persons within the area of audibility is necessary for the peace and wellbeing of residents and visitors to the City; and

WHEREAS, Tybee Island is unique in the location of business establishments, a county pier where events are conducted and residential dwellings that coexist in close proximity to commercial establishments that provide gatherings, music and other sources of sound; and

WHEREAS, wind directions and wind speed can have significant impacts on the distribution of sounds; and

WHEREAS, the City of Tybee Island has for in excess of 15 years explored alternative methods of addressing noise, noise complaints, disorderly behavior in various residential and other areas; and

WHEREAS, the City has attempted to improve the peace, tranquility and health and safety of residents and occupants of residential dwellings by controlling or limiting unreasonably loud noises through sound level controls based on decibel levels and in the opinion of many, the efforts have not been as successful as desired; and

WHEREAS, court decisions upholding the constitutionality of the restrictions on noise and noise producing activity where doing so creates "plainly audible" disturbances too occupants of nearby properties have been recognized and resulted in successful prohibitions and prosecutions; and

WHEREAS, the City of Tybee Island has previously adopted administrative procedures for civil penalties for certain Code violations which can include unreasonably loud noise violations;

NOW THEREFORE, it is hereby ordained by the governing authority of the City of Tybee Island duly assembled as follows:

SECTION I

Existing Tybee Code Sections identified as Article 4 of Chapter 22 "Noises" Sections 22-110 through 22-112 are hereby repealed in their entirety and are replaced with the Code Sections hereinafter set forth and designated numerically as hereinafter set forth.

ARTICLE IV. NOISES

Sec. 22-110. Definitions.

The following words, terms and phrases, when used in this article, shall have the meanings ascribed to them in this section, except where the context clearly indicates a different meaning:

Construction means any site preparation, assembly, erection, substantial repair, alteration, or similar action, for or of public or private rights-of-way, structures, utilities, or similar property.

Demolition means any dismantling, intentional destruction or removal of structures, utilities, public or private right-of-way surfaces, or similar property.

Emergency means any occurrence or set of circumstances involving actual or imminent physical or psychological trauma or property damage which demands immediate action.

Emergency work means any work performed for the purpose of alleviating or resolving an emergency.

Enclosed Building means all space between a floor and ceiling that is enclosed on all sides by solid walls or windows, exclusive of doorways, which extend from the floor to the ceiling.

Holidays means those holidays recognized by the U.S. Office of Personnel Management.

Mechanical Sound Making Devices means any radio receiving device, television, stereo, musical instrument, phonograph sound amplifier or other machines or devices for the producing, reproducing or amplifying of sound and/or noise.

Motor vehicle means any motor-operated vehicle licensed for use on the public highways, but not including a motorcycle.

Motorboat means any vessel which operates on water and which is propelled by a motor, including, but not limited to, boats, barges, amphibious craft, water ski towing devices and hover craft.

Motorcycle means any motor vehicle having a saddle or seat for the use of the rider and designed to travel on not more than three wheels in contact with the ground. The term shall include, but not be limited to, motorized bicycles and motor scooters.

Noise means any sound which disturbs humans or which causes or tends to cause an adverse psychological or physiological effect on humans.

Noisy Assembly means any gathering of more than one (1) person which creates noise.

Noise disturbance means any sound which endangers or injures the welfare, safety or health of human beings, or disturbs a reasonable person of normal sensitivities, or devalues or injures personal or real property, or is hereinafter defined.

Noise sensitive activities means activities which should be conducted under conditions of exceptional quiet including, but not limited to, operation of schools, libraries open to the public, churches, hospitals, and nursing homes.

Noise sensitive area means any area designated for the purpose of ensuring exceptional quiet and clearly posted with "noise sensitive area" signs, because of the noise sensitive activities conducted therein.

Official Public event means any event put on by, adopted, approved or endorsed by the City.

Person means any individual, partnership, firm, association, joint venture, public or private corporation, trust, estate, commission, board, public or private institution, utility, operative, state agency, municipality or other political subdivisions of this state, any interstate body, or any other legal entity.

Plainly audible shall mean any sound emanating from the specific sound-producing sources set forth below which can be heard from the distances set forth below, using the following sound measurement standards: Measurement shall be by the auditory senses of a person standing at a distance no less than the required minimum distance from the source of the sound. For music and other noise, words and phrases need not be discernable. For music and other noise, bass reverberations are included.

Powered model vehicle means any self-propelled airborne, waterborne, or land borne model plane, vessel, or vehicle, which is not designed to carry persons, including, but not limited to any model airplane, boat, car or rocket.

Public right-of-way means any street, avenue, boulevard, highway, sidewalk, lane or similar place which is owned or controlled by a governmental entity.

Public space means any real property, including any structure thereon, which is owned or controlled by a governmental entity.

Public works project means any project financed by public funds such as roads, highways, bridges or other construction on public or government owned property. It does not include projects merely approved by mayor and council.

Real property boundary means an imaginary line along the ground surface, and its vertical extension, which separates the real property owned by one person from that owned by another person, but not including intra-building real property divisions.

Residential means any property on which is located a building or structure used wholly or partially for living or sleeping purposes.

School means any place of learning or caring for children, both public and private.

Sound means an oscillation in pressure, particle displacement, particle velocity or other physical parameter, in a medium with internal forces that cause compression and rarefaction of that medium.

The description of sound may include any characteristic of such sound, including duration, intensity and frequency.

Used means and includes the words "intended," "designed," or "arranged to be used. "
(Code 1983, § 11-3-2)

Sec. 22-111. Exceptions.

The provisions of this article shall not apply to:

- (1) The emission of sound for the purpose of alerting persons to the existence of an emergency;
- (2) The emission of sound in the performance of emergency work by City or City Contractor;
- (3) Noises and/or sounds caused to be made by manufacturing, governmental, or commercial entities in the normal course of their business, however, the production of sound by gathering of persons, music or entertainment activities by restaurants, bars and/or similar establishments shall not be exempt under this subsection;
- (4) Agricultural activities, exclusive of those involving the ownership or possession of animals or birds;
- (5) Public mass transportation vehicles;
- (6) Church or clock carillons, bells, or chimes;
- (7) The emission of sound in the discharge of weapons or in fireworks displays for which a permit has been issued;
- (8) Public works projects;
- (9) Noises and/or sounds that are permitted by a special event permit pursuant to section 54-70, et seq; provided, however, that the producer or coordinator of the special event must comply with the terms, restrictions and conditions of the special event permit;
- (10) Sound volumes produced by radio, tape player, or other mechanical sound making device or instrument from within a motor vehicle on a street or highway, which sound is controlled by O.C.G.A. § 40-6-14;
- (11) Noises or sounds made by law enforcement and other public safety officials performing their public functions;
- (12) The emission of sound from a public space during an official public event; or
- (13) The emission of sound from a school or church during the regular scheduled hours of operation or during special events.
(Code 1983, § 11-3-3)
- (14) Noises or sounds made by the exploding of consumer fireworks on January 1, the last Saturday and Sunday in May, July 3, July 4, the first Monday in September, and December 31 of each year after 10:00 a.m. and up to and including the time of 11:59 p.m.; and on January 1 of each year beginning at the time of 12:00 Midnight and up to and including the ending time of 1:00 a.m.
- (15) Generators during times of power outages.

Sec. 22-112. Noise disturbance prohibited.

(a) *Prohibited conduct.*

(1) *Restrictions of 300 feet for 7:00 a.m. through 10:00 p.m. Sunday through Thursday and 7:00 a.m. through 12:00 midnight on Friday and Saturday and holidays.*

a. *Mechanical sound-making devices.* It is unlawful for any person or persons to play, use, operate, or permit to be played, used, or operated any Mechanical Sound Making Devices at such a volume and in such a manner so as to create, or cause to be created, any noises or sounds which are plainly audible at a distance of 300 feet or more from the building, structure or vehicle, or in the case of real property, beyond the property limits, in which it is located, whichever is farthest, between the hours of 7:00 a.m. and 10:00 p.m. Sunday through Thursday and between the hours of 7:00 a.m. and 12:00 midnight on Friday and Saturday and holidays.

b. *Human-produced sounds.* It is unlawful for any person or persons to yell, shout, whistle, or sing on the public streets or sidewalks or on private property so as to create, or cause to be created, any noises or sounds which are plainly audible at a distance of 300 feet or more from the place, building, structure, or in the case of real property, beyond the real property boundary, in which the person is located, whichever is farthest, between the hours of 7:00 a.m. and 10:00 p.m. Sunday through Thursday and between the hours of 7:00 a.m. and 12:00 midnight on Friday and Saturday and holidays.

c. *Commercial advertising.* It is unlawful for any person or persons to use, operate, or permit to be used or operated any radio receiving device, musical instrument, phonograph, loud speaker, sound amplifier or other machine or device for the production or reproduction of sound which is cast upon the public streets or other public property for the purpose of commercial advertising or which serves to attract the attention of the public to any building, structure or vehicle in such a manner so as to create, or cause to be created, any noises or sounds which are plainly audible at a distance of 300 feet or more from the source of the sound cast upon the public streets or other public property or from the building, structure, or in the case of real property, beyond the real property boundary, in which it is located, whichever is farthest, between the hours of 7:00 a.m. and 10:00 p.m. Sunday through Thursday and between the hours of 7:00 a.m. and 12 midnight on Friday and Saturday.

d. *Party noise.* It is unlawful for any person or persons in charge of a party or other social event that occurs on any private property to allow that party or social event to produce noise in such a manner that such noise is plainly audible at a distance of 300 feet or more from the building or structure from which the noise is emanating or in the case of real property, beyond the real property boundary, on which the party or social event is located, whichever is farthest, between the hours of 7:00 a.m. and 10:00 p.m. Sunday through Thursday and between the hours of 7:00 a.m. and 12:00 midnight on Friday and Saturday and holidays. For the purposes of this subsection, a "person in charge of a party or other social event" shall mean any adult person who resides in or on the premises involved in such party or social event or the adult responsible for having leased, rented or who manages the property or is otherwise responsible therefore and is present at such party or social event. For the purposes of this subsection, "noise" shall mean the same sounds, or any combination thereof, as described in paragraphs a. or b. above.

(2) *Restrictions of 100 feet for 10:00 p.m. through 7:00 a.m. Sunday through Thursday and 12:00 midnight through 7:00 a.m. on Saturday and Sunday.*

a. *Mechanical sound-making devices.* It is unlawful for any person or persons to play, use, operate, or permit to be played, used, or operated any Mechanical Sound Making Devices at such a volume and in such a manner so as to create, or cause to be created, any noises or sounds which are plainly audible at a distance of 100 feet or more from the building, structure or vehicle, or in the case of real property, beyond the property limits, in which it is located, whichever is farthest, between the hours of 10:00 p.m. and 7:00 a.m. Sunday through Thursday and between the hours of 12:00 midnight and 7:00 a.m. on Friday and Saturday and holidays.

b. *Human-produced sound.* It is unlawful for any person or persons to yell, shout, hoot, whistle, or sing on the public streets or sidewalks or on private property so as to create, or cause to be created, any noises or sounds which are plainly audible at a distance of 100 feet or more from the place on public streets and sidewalks, or in the case of private real property, beyond the real property boundary, on which the person is located, whichever is farthest, between the hours of 10:00 p.m. and 7:00 a.m. Sunday through Thursday and between the hours of 10:00 p.m. and 7:00 a.m. on Saturday and Sunday and holidays.

c. *Commercial advertising.* It is unlawful for any person or persons to use, operate, or permit to be used or operated any radio receiving device, musical instrument, phonograph, loud speaker, sound amplifier or other machine or device for the production or reproduction of sound which is cast upon the public streets or other public property for the purpose of commercial advertising or which serves to attract the attention of the public to any building, structure or vehicle in such a manner so as to create, or cause to be created, any noises or sounds which are plainly audible at a distance of 100 feet or more from the source of the sound cast upon the public streets or other public property or from the building, structure, or in the case of real property, beyond the real property boundary, in which it is located, whichever is farthest, between the hours of 10:00 p.m. and 7:00 a.m. Sunday through Thursday and between the hours of 12:00 midnight and 7:00 a.m. on Saturday and Sunday and holidays.

d. *Party noise.* It is unlawful for any person or persons in charge of a party or other social event that occurs on any private property to allow that party or event to produce noise in such a manner so as to such noise is plainly audible at a distance of 100 feet or more from the building or structure from which the party noise is emanating or in the case of real property, beyond the real property boundary, on which the party or social event is located, whichever is farthest, between the hours of 10:00 p.m. and 7:00 a.m. Sunday through Thursday and between the hours of 10:00 p.m. and 7:00 a.m. on Saturday and Sunday and holidays. For the purposes of this subsection, a "person in charge of a party or other social event" shall mean any adult person who resides in or on the premises involved in such party or social event and is present at such party or social event or the adult responsible for having leased, rented or who manages the property or is otherwise responsible therefore. For the purposes of this subsection, "noise" shall mean the same sounds, or any combination thereof, as described in paragraphs a. or b. above.

(3) Restrictions regarding noise produced by consumer fireworks between 10:00 a.m. and up to and including 11:59 p.m. on all days. It is unlawful for any person to use, explode or cause to be exploded any consumer fireworks to produce noise in such a manner that such noise is plainly audible at a distance of 100 feet or more from the place, or in the case of real property, beyond the

property limits in which the fireworks are being used, exploded or caused to be exploded, whichever is farthest, between the hours of 10:00 a.m. and 11:59 p.m. on all days. For the purposes of this section, the term "consumer fireworks" shall have the meaning set forth in O.C.G.A. § 25-10-1(a)(1), but such term shall not include those items excluded therefrom in O.C.G.A. § 25-10-1(b) as such code section is enacted as of July 1, 2018 or as may be amended in the future. See also, Sec. 42-66, and O.C.G.A. § 25-10-2 prohibiting the use of such fireworks after 11:59 p.m. except as specifically authorized.

(4) Restrictions for areas within apartments, condominiums, townhouses, duplexes, or other such residential dwelling units.

Except for persons within commercial enterprises that have an adjoining property line or boundary with a residential dwelling unit, it is unlawful for any person to make, continue, or cause to be made or continued any noise in such a manner as to be plainly audible to any other person a distance of five feet beyond the adjoining property line wall or boundary of any apartment, condominium, townhouse, duplex, or other such residential dwelling units with adjoining points of contact.

For the purposes of this subsection, "noise" shall mean human-produced sounds of yelling, shouting, whistling, singing, or mechanically-produced sounds made by radio-receiving device, television, stereo, musical instrument, phonograph sound amplifier or other machines or devices for the producing, reproducing, or amplifying of sound, or any combination thereof.

For the purposes of this subsection, "property line or boundary" shall mean an imaginary line drawn through the points of contact of (1) adjoining apartments, condominiums, townhouses, duplexes or other such residential dwelling units with adjoining points owned, rented, or leased by different persons; or (2) adjoining common areas or adjoining exterior walls. Said property line or boundary includes all points of a plane formed by projecting the property line or boundary including the ceiling, the floor, and the walls.

(b) For Property bordering residential (not to exclude property separated by a right of way, street or easement, public or private) including other residential property.

In addition to all other provisions of this Article, if the property boundary of a property borders residential property, the following shall apply:

- (1) It shall be unlawful for any person or persons to play, use, operate, or permit to be played, used, or operated any Mechanical Sound Making Devices between the hours of 10:00 p.m. and 7:00 a.m. Sunday through Thursday and 12:00 midnight through 7:00 a.m. Friday and Saturday and holidays, unless the music is played exclusively within an enclosed building. In addition to the foregoing, any use or operation of any Mechanical Sound Making Devices between the restricted hours which produces noises that are plainly audible from the property boundary of the property is a violation of this section.
- (2) It shall be unlawful for any person or persons to constitute a Noisy Assembly, or permit property under his or her control to be used for a Noisy Assembly, between the hours of

10:00 p.m. and 7:00 a.m. Sunday through Thursday. And 11:00 p.m. through 7:00 a.m. Friday and Saturday and holidays, unless the Noisy Assembly is exclusively within an enclosed building. In addition to the foregoing, any Noisy Assembly between the restricted hours which produces noises than are plainly audible from the property boundary of the property is a violation of this section.

(c) *Equipment use restrictions.* Regardless of the other provisions of this Article, the following equipment may not be operated between the time of sunset and 7:00 a.m.: Monday-Friday and on Saturday and Sunday the time of sunset to 10:00 a.m.:

- (1) Electrical power tools.
- (2) Motor powered, muffler equipped lawn, garden, and tree trimming equipment except residential lawn mowers.
- (3) Construction equipment, which includes landscaper's lawn mowers and other landscaping motorized equipment.
- (4) Construction noise . Between the hours of 11:00 p.m. and 6:00 a.m., construction noise of any type, including, but not limited to, noise caused by the erection (including excavation), demolition, alteration, or repair of any building, as well as the operation of any earth-moving equipment, crane, saw, drill, pile driver, steam shovel, pneumatic hammer, hoist, automatic nailer or stapler, or any similar equipment, shall not be plainly audible within any residential zoning district more than 100 feet beyond the property boundary of the property from which the noise emanates.

A variance from the above-referenced hours of operation for construction noise may be requested, in writing, at least 48 hours prior to the proposed construction operation, for consideration by the Director of the Building Inspections and Permit Department. Such a request shall state:

- 1)The reasons that support a claim of urgent need based on specific loss or inconvenience for such a variation from the allowable work hours;
- 2)The impact that the denial of this request would have on the applicant's project and the surrounding properties;
- 3)The steps which have been taken by the applicant to communicate those needs and impacts to owners of surrounding and nearby properties;
- 4)The steps that have or will be taken to limit the impact of the proposed activity upon surrounding and nearby properties; and
- 5)The possible risks to public health and safety.

If the Director finds that the application adequately demonstrates the urgent need for a variance from the above allowable work hours, adequately provides for mitigation of the impact upon surrounding and nearby properties, and poses no additional risk to public health and safety, then permission shall be granted for a variance to alter the allowable work hours during one ten-day period.

(Code 1983, § 11-3-4; Ord. of 4-29-2005; Ord. of 7-26-2007)

SECTION II

All ordinances and parts of ordinances in conflict herewith are expressly repealed.

SECTION III

It is the intention of the governing body, and it is hereby ordained, that the provisions of this ordinance shall become effective and be made a part of the Code of Ordinances, City of Tybee Island, Georgia, and the sections of this ordinance may be renumbered to accomplish such intention.

SECTION IV

This ordinance shall be effective upon its adoption by the Mayor and Council pursuant to The Code of the City of Tybee Island, Georgia.

This Ordinance shall become effective on _____ day of _____, 2020.

ADOPTED THIS ____ DAY OF _____, 2020.

MAYOR

ATTEST:

CLERK OF COUNCIL

FIRST READING: _____

SECOND READING: _____

ENACTED: _____

File Attachments for Item:

12. Second Reading, 2020-21, Alcohol Restrictions (Address discussion at workshop for a committee to be formed)

ORDINANCE NO. 2020-21 ____

AN ORDINANCE TO AMEND THE CODE OF ORDINANCES OF THE CITY OF TYBEE ISLAND SO AS TO REVISE PROVISIONS PROHIBITING CONSUMPTION OF ALCOHOL OR POSSESSION OF ALCOHOL BEVERAGES IN OPEN CONTAINERS IN CERTAIN DESIGNATED LOCATIONS AND TO REPEAL INCONSISTENT OR CONFLICTING ORDINANCES, TO RECOGNIZE THE ADOPTION OF CIVIL PENALTIES FOR OFFENSES, TO ESTABLISH AN EFFECTIVE DATE AND TO AUTHORIZE THE ENFORCEMENT THEREOF

WHEREAS, the duly elected governing authority for the City of Tybee Island, Georgia, is authorized under Article 9, Section 2, Paragraph 3 of the Constitution of the State of Georgia to adopt reasonable ordinances to protect and improve the public health, safety, and welfare of the citizens of Tybee Island, Georgia, and

WHEREAS, the duly elected governing authority for the City of Tybee Island, Georgia, is the Mayor and Council thereof; and

WHEREAS, the governing authority desires to adopt ordinances under its police and home rule powers; and

WHEREAS, the control of consumption of alcoholic beverages or possession of alcoholic beverages in open containers in certain locations is necessary for the peace and wellbeing of residents and visitors to the City; and

WHEREAS, open consumption of alcoholic beverages is inconsistent with the culture the City wishes to promote for well being of residents and visitors alike; and

WHEREAS, consumption of alcoholic beverages on certain public property has led to an increase in litter not only on the beach but other public lands; and

WHEREAS, there is concern that permitting unrestricted consumption of alcohol can lead to abuse to such extent as to put persons and law enforcement in danger; and

WHEREAS, the restricting of consumption of alcohol in certain locations would promote public safety; and

WHEREAS, the City of Tybee Island has previously adopted administrative procedures for civil penalties for certain Code violations which could include unlawful consumption of alcohol in restricted areas;

NOW THEREFORE, it is hereby ordained by the governing authority of the City of Tybee Island duly assembled as follows:

SECTION I

Existing Tybee Code Sections identified as Article 1 of Chapter 6 “Consumption of Alcoholic Beverages in Public” Section 6-8 is hereby revised and suspended in its entirety and is temporarily replaced with the Code Section hereinafter set forth below, from January 1, 2021 until August 31, 2021 unless extended or modified by action of the Mayor and Council.

ARTICLE 1, CHAPTER 6

Sec. 6-8. – Consumption of Alcoholic Beverages in Public Areas.

(a) Except as set forth below, alcoholic beverages may be consumed in public areas from a metal can or a non-glass cup with a capacity of 25.4 fluid ounces or less.

(b) The consumption of alcoholic beverages or possession of an open container of alcohol is strictly prohibited in the following area (“Prohibited Open Container Area”) defined as: 1) The festival area previously adopted and codified at Section 54-72(b) but also specifically 14th St to the mean low water line of the Atlantic Ocean and proceeding south encompassing the beach and land area west to Butler Ave to Chatham Ave AND the Back River beach areas to and including Alley 3, including all public parking lots, parking places, boat or launch ramps, rights of way, streets, sidewalks , open areas, beaches and adjacent waters.

Or

The council may approve a map of the area.

The following exceptions exist to this prohibition:

1) This prohibition does not impact the ability of Chatham County or its designated vendor to sell alcoholic beverages on the Walter Parker Pier, nor of patrons thereof to consume such beverages while on the Pier.

2) Any business located in the Prohibited Open Container Area, which holds a valid license for the sale of alcoholic beverages and has a permit allowing service to customers on the adjacent public sidewalk, may serve alcoholic beverages to its customers in open containers on the sidewalk. However, any such alcoholic beverage served in the approved sidewalk area may not be removed out of the sidewalk and must be consumed on the sidewalk adjacent to the businesses' premises.

3) Alcoholic beverages may be consumed or possessed in open containers pursuant to any event properly organized and permitted as set forth in the provisions of Article III of Chapter 54.

c) Any person violating any provisions, rules or regulations of this article, upon conviction, shall be subject to punishment as provided in Section 1-8 and as provided by law. (Code 1983, §9-2-9; Ord. No. 12-2013-D, §1, 4-11-2013) or as is provided in any ordinance providing administrative/civil penalties for unlawful consumption of alcoholic beverages.

SECTION II

All ordinances and parts of ordinances in conflict herewith are expressly repealed.

SECTION III

It is the intention of the governing body, and it is hereby ordained, that the provisions of this ordinance shall become effective and be made a part of the Code of Ordinances, City of Tybee

Island, Georgia, and the sections of this ordinance may be renumbered to accomplish such intention.

SECTION IV

Following adoption by the Mayor and Council pursuant to The Code of the City of Tybee Island, Georgia, this ordinance shall be effective on January 1, 2021. This ordinance shall expire at midnight on August 31, 2021 unless extended as provided for by law.

This Ordinance shall become effective on _____ day of _____, 2020.

ADOPTED THIS ____ DAY OF _____, 2020.

MAYOR

ATTEST:

CLERK OF COUNCIL

FIRST READING: _____

SECOND READING: _____

ENACTED: _____

File Attachments for Item:

13. Second Reading, 2020-22, Tree Permit Required, Sec 7-040

ORDINANCE NO. 2020 ____

AN ORDINANCE TO AMEND THE CODE OF ORDINANCES TO ADOPT CHANGES TO THE CITY TREE ORDINANCE REMOVAL REGULATIONS; TO PROHIBIT THE USE OF PALM TREES AS MITIGATION TREES (EXCEPT AS TO PALM TREES REMOVED) TO MAKE CLARIFICATIONS AND ADDITIONAL REVISIONS, AND TO ESTABLISH AN EFFECTIVE DATE

WHEREAS, the duly elected governing authority for the City of Tybee Island, Georgia, is authorized under Article 9, Section 2, Paragraph 3 of the Constitution of the State of Georgia to adopt reasonable ordinances to protect and improve the public health, safety, and welfare of the citizens of Tybee Island, Georgia, and

WHEREAS, the duly elected governing authority for the City of Tybee Island, Georgia, is the Mayor and Council thereof; and

WHEREAS, the governing authority desires to adopt ordinances under its police and home rule powers; and

WHEREAS, the City of Tybee Island has previously adopted a tree removal ordinance which needs revisions so as to impose additional requirements for mitigating trees removed without a permit to do so; and

WHEREAS, the amendment should also address and clarify that in the event there is a violation, palm trees may not be used as replacement trees; and

WHEREAS, the amendment should also make additional clarifying changes to the existing ordinance;

NOW, THEREFORE, it is hereby ordained by the governing authority of the City of Tybee Island that the Code of Ordinances is hereafter amended as follows:

SECTION I

Section 7-040 is amended so as to strike in the caption thereof and in the body thereof the word "building" and clarify that "tree" should be placed in its stead so that hereafter such section shall read as follows:

7-040 Tree Permit Required

Any person desiring to clear land or remove trees to a density below that required in Section 7-050 or remove a significant tree pursuant to this Article shall apply for a tree permit from the City. See Section 9-030 of this Land Development Code for requirements and application procedure. A tree survey must be submitted before a permit can be issued.

SECTION II

Further, Section 7-060 (B)(2), Removal of significant trees, shall be revised so as to strike the word "native" and replace it with "significant" so that hereafter such subsection shall read:

2. Significant trees left remaining on the site may be counted as replacement trees according to the mitigation schedule. These trees must be noted on the plat and shall be protected as a tree as defined by Section 2-010.

SECTION III

Further, Section 7-080 shall be revised in its entirety so as to hereinafter read as follows:

Sec. 7-080. Standards for tree planting and replacement.

(A) *Pursuant to building or tree permit.* Trees planted or replaced, or left remaining on the site pursuant to a validly issued building or tree permit in accordance with this article shall be botanically compatible with local conditions, healthy, disease and pest free, and shall have a minimum size of two inches DBH, caliper measure. The permittee/landowner shall choose the species of replacement trees from the significant species list for Tybee Island. At least one replacement tree or remaining tree shall be of the same species as the tree(s) that are planned to be removed. In no case may palm trees be used as a replacement for any tree except a palm to be removed. Ideally, planting should be done immediately following construction or in the earliest growing season thereafter.

(B) *Pursuant to citation of violation.* Replacement trees planted pursuant to citation of violation shall be of the same type (species) as the tree being removed and shall be the maximum DBH that is commercially available and at least 4" DBH. The aggregate DBH of trees planted as replacement shall equal the DBH of the tree that was removed in violation of this article.

(C) *Survival of replacement trees.* All replanted or replacement trees must survive at least two full calendar years for the permittee/landowner to be considered to be in full compliance with this article. If the replanted tree becomes unhealthy or dies, it must be removed from the site and replaced as soon as conditions permit. This duration is not to exceed one calendar year.

(D) *Off-site tree planting option.* If it is not possible to replant trees to the specifications required in these regulations, the applicant may choose to plant the required trees on city property in a location specified by the zoning administrator. A donation may be made to the trees for Tybee fund. All significant trees may be mitigated at a cost of \$100.00 per inch.

(E) *Definition of replanted, remaining, and replacement trees.* All replanted, remaining, or replacement trees shall be considered a "tree" as defined in section 2-010.

SECTION IV

All ordinances and parts of ordinances in conflict herewith are expressly repealed, however all other provisions of the existing tree ordinance shall remain in full force and effect except as specifically changed herein.

SECTION V

It is the intention of the governing body, and it is hereby ordained, that the provisions of this ordinance shall become effective and be made a part of the Code of Ordinances, City of Tybee Island, Georgia, and the sections of this ordinance may be renumbered to accomplish such intention.

SECTION VI

This ordinance shall be effective upon its adoption by the Mayor and Council pursuant to The Code of the City of Tybee Island, Georgia.

This Ordinance shall become effective on _____ day of _____, 2020.

ADOPTED THIS ____ DAY OF _____, 2020.

MAYOR

ATTEST:

CLERK OF COUNCIL

FIRST READING: _____

SECOND READING: _____

ENACTED: _____

File Attachments for Item:

14. Resolution, 2020-15, Authorizing Adoption of the Chatham County Multi-Jurisdictional Pre-Disaster Hazard Mitigation Plan

RESOLUTION 2020- 15

**A RESOLUTION AUTHORIZING ADOPTION OF
THE CHATHAM COUNTY MULTI-JURISDICTIONAL PRE-DISASTER
HAZARD MITIGATION PLAN**

WHEREAS, the citizens and property within Chatham County and its municipal governments are subject to the effects of natural and human-caused hazards which may result in loss of life and property, economic hardship, and threats to public health and safety; and

WHEREAS, Section 322 of the Federal Disaster Mitigation Act of 2000 states that local governments must develop an All-Hazards Mitigation Plan in order to be eligible to receive future Hazard Mitigation Grant Program Funds and other disaster-related assistance funding and that said Plan must be updated and adopted within a five year cycle; and

WHEREAS, it is the intent of the Mayor and Council of the City of Tybee Island to fulfill this obligation in order that the County and City will be eligible for federal and state assistance in the event that a state of disaster is declared for a hazard event affecting the County and/or the City; and

WHEREAS, Chatham County and its municipal governments have completed a comprehensive review of the previously approved Hazard Mitigation Plan and have updated said plan as required under regulations at 44 CFR Part 201 and according to guidance issued by the Federal Emergency Management Agency and the Georgia Emergency Management & Homeland Security Agency; and

WHEREAS, the Mayor and Council for the City desires to seek ways to mitigate the impact of identified hazard risks and the Chatham County Multi-Jurisdictional Pre-Disaster Hazard Mitigation Plan recommends mitigation activities that will reduce losses to life and property affected by both natural and human-caused hazards that may affect the County and City of Tybee Island.

NOW, THEREFORE, be it resolved that the Mayor and City Council of the City of Tybee Island hereby adopts

1. Adopts the Chatham County Multi-Jurisdictional Pre-Disaster Hazard Mitigation Plan.
2. Agrees to take such other official action as may be reasonably necessary to carry out the objectives of the Hazard Mitigation Plan.

Adopted this _____ day of _____, 2020.

Signed: Mayor, City of Tybee Island

Attest: Clerk of City of Tybee Island

(Seal)

File Attachments for Item:

15. Bubba Hughes: Discussion Only: 2020-24, Amendment, By the Drink Licensing to require Liability Insurance , Sec 6-48

ORDINANCE NO. 2020-24

AN ORDINANCE TO AMEND THE CODE OF ORDINANCES OF THE CITY OF TYBEE ISLAND SO AS TO INCLUDE PROVISIONS REQUIRING PROOF OF CERTAIN INSURANCE COVERAGES IN ASSOCIATION WITH APPLICATIONS FOR ALCOHOL LICENSES AND TO REPEAL INCONSISTENT OR CONFLICTING ORDINANCES AND TO ESTABLISH AN EFFECTIVE DATE

WHEREAS, the duly elected governing authority for the City of Tybee Island, Georgia, is authorized under Article 9, Section 2, Paragraph 3 of the Constitution of the State of Georgia to adopt reasonable ordinances to protect and improve the public health, safety, and welfare of the citizens of Tybee Island, Georgia, and

WHEREAS, the duly elected governing authority for the City of Tybee Island, Georgia, is the Mayor and Council thereof; and

WHEREAS, the governing authority desires to adopt ordinances under its police and home rule powers; and

WHEREAS, the protection of residents and visitors is of paramount importance; and

WHEREAS, it is desirable that businesses which sell alcoholic beverages have sufficient insurance coverage to protect residents and visitors from injuries and damages which arise from the operations of such businesses; and

NOW THEREFORE, it is hereby ordained by the governing authority of the City of Tybee Island duly assembled as follows:

SECTION I

Existing Tybee Code Sections identified as Article I of Chapter 6 “Regulation of Sales by the Drink” Section 6-11 is hereby repealed in its entirety and is replaced with the Code Section hereinafter set forth below.

Sec. 6-11. - Regulation of sales by the drink.

Any person issued a permit under the provisions of this article for the sale of alcoholic beverages by the drink shall be subject to the following regulations, to wit:

- (1) All of the laws of the state pertaining to the sale of alcoholic beverages by retail liquor dealers.
- (2) **Shall maintain general liability and liquor liability insurance.**
- (3) Shall not serve or sell to any intoxicated person.
- (4) Shall not serve or sell to any minor.
- (5) Shall keep their place of business or establishment sufficiently lighted to discourage any disorderly conduct on the premises.
- (6) The mayor and council reserve the right to promulgate additional regulations or ordinances pertaining to the conduct of the business of selling distilled spirits or alcoholic beverages for beverage purposes by the drink and any person licensed hereunder shall be subject to such additional regulations that may be promulgated from time to time by the mayor and council.
- (7) All establishments duly licensed hereunder must fully comply with all sanitary requirements promulgated by the city.
- (8) All musical units or amusement machines installed in any establishments licensed hereunder must be properly registered with the clerk of council.
- (9) All transactions conducted on the premises of any establishment licensed hereunder involving the sale or transfer of alcoholic beverages must be for cash or its equivalent. Credit transactions are declared to be illegal.

(Code 1983, § 9-2-24)

SECTION II

Existing Tybee Code Sections identified as Article II of Chapter 6 “Application for License for Liquor Sales” Section 6-48 is hereby repealed in its entirety and is replaced with the Code Section hereinafter set forth below.

Sec. 6-48. - Application for license for liquor sales.

Every person engaged within the city limits or that is engaged hereafter, intending to carry on any one or more such business shall, before engaging or continuing in said business, file with the city an application for permit or license to conduct and carry on such business; said application shall set forth the location of the building where such business is to be conducted. **At the time the application is submitted, the applicant shall file with their application a certificate of liquor liability insurance (dram shop) and a certificate of commercial general liability insurance, in effect for the license period and issued by an**

insurer required to be licensed pursuant to state law. Both the liquor liability insurance and the commercial general liability insurance shall provide an annual aggregate policy limit of not less than \$1,000,000.00 per policy year. A 30 day notice of cancellation in favor of the City of Tybee must be endorsed to the policies and attached to the certificate.

(Code 1983, § 9-2-21)

SECTION III

Existing Tybee Code Sections identified as Article II of Chapter 6 “Revocation of License or Permit” Section 6-52 is hereby repealed in its entirety and is replaced with the Code Section hereinafter set forth below.

Sec. 6-52. - Revocation of license or permit.

(a) **Grounds.** The following shall be grounds for revocation of all alcoholic beverage licenses:

- (1) **Failure of wholesaler or retailer to pay license or excise taxes.**
- (2) **Commission of any act in violation of the federal, state or local law or ordinances which would disqualify a person from obtaining a license.**
- (3) **Selling, distributing or buying alcoholic beverages on which no local or state tax has been paid.**
- (4) **Commission of any acts in violation of federal, state or local laws or ordinances or running of a licensed business where such violations frequently or regularly occur so as to cause the chief of police to recommend a revocation of the license.**
- (5) **The change in any circumstances of any licensee in such way that had such circumstance existed when the application was filed, a license would not have been granted.**
- (6) **Any recurrent breaches of the peace, disturbances or altercations occurring on licensed premises or the failure of the licensee or his employees promptly to report to the chief of police any violation of the laws or ordinances governing the licensing and sale of beer, wine or alcoholic beverages of which he has knowledge.**
- (7) **Any conduct on the part of the license holder or his employees contrary to the public health, safety, health or morals of the city's citizens.**
- (8) Failure to maintain insurance as required in Section 6-48.**
- (9) **Failure to abide by any of the provisions of this chapter.**

(b) **Procedures.** The following procedures shall be followed in revoking all permits granted hereunder:

- (1) **Notice shall be given to the holder of a permit at least five days in advance that the mayor and council will hear a recommendation that the license be revoked, and this**

notice shall include the specific grounds on which this recommendation to the mayor and council will be made.

- (2) The clerk of council shall notify the permit holder and the chief of police as to the time that a recommendation for revocation will be heard.
- (3) The mayor and council shall hear a recommendation for revocation at one of its regular meetings or at a special meeting where notice has been given as required herein at which time the holder of said permit and any other interested parties will be heard.
- (4) No permit shall be revoked until a majority of the mayor and council so decide at the time of or subsequent to the hearing on the recommendation for revocation.

(Code 1983, § 9-2-25)

SECTION IV

Existing Tybee Code Sections identified as Article III of Chapter 6 “Application Required”

Section 6-88 is hereby repealed in its entirety and is replaced with the Code Section hereinafter set forth below.

Sec. 6-88. - Application required.

Every person engaged within the city limits in carrying on the business of handling or selling malt beverages, as allowed by the act of the state legislature approved March 23, 1985 (known as the Beer License Act), at wholesale, or retail, and every person hereafter intending to carry on such business in said city, as aforesaid, shall before continuing said business, or engaging therein, file with the clerk of the city an application for a permit to conduct and carry on such business; said application shall set forth the location and building where such business is being conducted or is to be conducted. **At the time the application is submitted, the applicant shall file with their application a certificate of liquor liability insurance (dram shop) and a certificate of commercial general liability insurance, in effect for the license period and issued by an insurer required to be licensed pursuant to state law. Both the liquor liability insurance and the commercial general liability insurance shall provide an annual aggregate policy limit of not less than \$1,000,000.00 per policy year. A 30 day notice of cancellation in favor of the City of Tybee must be endorsed to the policies and attached to the certificate.**

(Code 1983, § 9-2-31; Ord. No. [7-2019](#), § 1, 4-25-2019)

SECTION V

Existing Tybee Code Sections identified as Article II of Chapter 6 “Revocation of Permit”

Section 6-92 is hereby repealed in its entirety and is replaced with the Code Section hereinafter set forth below.

Sec. 6-92. - Revocation of permit.

(a) **Grounds.** The following shall be grounds for revocation of all malt beverage licenses:

- (1) **Failure of wholesaler or retailer to pay license or excise taxes.**
- (2) **Commission of any act in violation of the federal, state or local laws or ordinances which would disqualify a person from obtaining a license.**
- (3) **Selling, distributing or buying malt beverages on which no local or state tax has been paid.**
- (4) **Commission of any acts in violation of federal, state or local laws or ordinances or running of a licensed business where such violations frequently or regularly occur so as to cause the chief of police to recommend a revocation of the license.**
- (5) **The change in any circumstances of any licensee in such way that had such circumstances existed when the application was filed, a license would not have been granted.**
- (6) **Any recurrent breaches of the peace, disturbances or altercations occurring on licensed premises or the failure of the licensee or his employees promptly to report to the chief of police any violation of the laws or ordinances governing the licensing and sale of beer, wine or alcoholic beverages of which he has knowledge.**
- (7) **Any conduct on the part of the license holder or his employees contrary to the public health, safety, health or morals of the city's citizens.**
- (8) Failure to maintain insurance as required by Section 6 – 88.**
- (8) **Failure to abide by any of the provisions of this article.**

(b) **Procedures.** The following procedures shall be followed in revoking all permits granted hereunder:

- (1) **Notice shall be given to the holder of a permit at least five days in advance that the mayor and council will hear a recommendation that the license be revoked, and this notice shall include the specific grounds on which this recommendation to the mayor and council will be made.**
- (2) **The clerk of council shall notify the permit holder, and the chief of police of the time that a recommendation for revocation will be heard.**
- (3) **The mayor and council shall hear a recommendation for revocation at one of its regular meetings or at a special meeting where notice has been given as required herein at which time the holder of said permit and any other interested parties will be heard.**

- (4) No permit shall be revoked until a majority of the mayor and council so decide at the time of or subsequent to the hearing on the recommendation for revocation.**

(Code 1983, § 9-2-35)

SECTION VI

All ordinances and parts of ordinances in conflict herewith are expressly repealed.

SECTION VII

It is the intention of the governing body, and it is hereby ordained, that the provisions of this ordinance shall become effective and be made a part of the Code of Ordinances, City of Tybee Island, Georgia, and the sections of this ordinance may be renumbered to accomplish such intention.

This Ordinance shall become effective on _____ day of _____, 2020.

ADOPTED THIS ____ DAY OF _____, 2020.

MAYOR

ATTEST:

CLERK OF COUNCIL

FIRST READING: _____

SECOND READING: _____

ENACTED: _____

File Attachments for Item:

18. Planning Commission Minutes -October 19, 2020

PLANNING COMMISSION

Demery Bishop
Ron Bossick
Charles Matlock
Elaine T. McGruder
David McNaughton
J. Whitley Reynolds
Alan Robertson



CITY MANAGER
Shawn Gillen

COMMUNITY DEVELOPMENT DIRECTOR
George Shaw

CITY ATTORNEY
Edward M. Hughes

**Planning Commission Meeting
MINUTES
October 19, 2020**

Chair Bishop called the October 19, 2020 Tybee Island Planning Commission meeting to order. Commissioners present were **Charles Matlock, Elaine T. McGruder, Alan Robertson, Vice Chair Ron Bossick** and **David McNaughton**. **J. Whitley Reynolds** was absent.

Consideration of Minutes:

Chair Demery Bishop asked for consideration of the September 21, 2020 minutes. **Commissioner Elaine T. McGruder** made a motion to approve. **Vice Chair Ron Bossick** seconded. The vote to approve was unanimous.

Disclosures/Recusals:

Chair Demery Bishop asked if there were any Disclosures or Recusals. There were none.

Old Business:

Text Amendment: Sec. 3-190 Swimming pool requirements.

George Shaw stated he has been unable to find a company that would come to the island and fill a pool. He stated it would probably be taken up by someone if this ordinance gets passed. **Commissioner David McNaughton** asked George Shaw how this will be enforced. **George Shaw** stated he would tell the customer that they would have to have the pool filled from water off the island and ask to see a receipt for the water. **Chair Bishop** asked George Shaw if he could look into monitoring the meter for that day they will be filling the pool. **George Shaw** stated he would look into that. **Anna Butler** who lives at 1212 Fifth Avenue Tybee Island, approached the Planning Commission and stated she works with many Construction companies around the state and would be available to fill pools on Tybee. **Commissioner Elaine McGruder** made a motion to approve. No second was made so motion failed. **Commissioner Elaine McGruder** made a motion to take out the wording that has to do with refills and renovations and only leave the wording for new construction of pools. **Commissioner David McNaughton** seconded. The vote to approve with changes was four approve and one against. Motion with changes was approved.

New Business:

Discussions:

Adjournment: 7:30pm

Lisa L. Schaaf